

Valerie Mk2

Owner's Manual



SKAA[®] Pro Wireless Vocal Microphone



designed in Canada ...
to rock the whole universe of SKAA speakers, headphones and receivers



Introduction

Thank you for choosing Valerie Mk2; the SKAA Pro wireless vocal microphone by Dillinger Labs. Valerie Mk2 features dual mode SKAA & SKAA Pro operation, an Analog Preamp with a dedicated gain fader and Fat Channel signal processing, all built in.

- Valerie Mk2 uses pro-grade SKAA wireless audio
- 100% bluetooth and WiFi free
- Works with all SKAA Speakers/Receivers including products by SOUNDBOKS, Wet Sounds, Electrotec, Dillinger Labs & Cewin Vega
- 35 meter reliable wireless range
- Supports both SKAA and SKAA Pro modes
- Latency is 19 ms in SKAA Pro Mode and 36 ms in SKAA Mode
- Valerie Mk2 can feed up to 4 Speakers/Receivers in SKAA mode and 2 in SKAA Pro mode
- Condenser (Electret) mic capsule for vocal detail
- Fat Channel signal processing is built in to thicken and sweeten your vocal sound
- 6 Fat Channel Presets; each delivering a different combination of gate, compression and EQ, plus a 7th **none** Preset when you want to cook your own
- Analog Mic Preamp is built in
- Compressor in the **analog** signal path (before the ADC) for maximum signal conditioning benefits
- Drive the Fat Channel as soft or as hard as you like by adjusting the analog Preamp Gain using the dedicated fader
- With the 6 Fat Channel presets and the ability to finely control Preamp Gain (completely separate from the system volume), you can craft a wide array of sounds right from Valerie's user interface
- Digitally control Global Volume (power amp volume) of all downstream SKAA Speakers/Receivers with the dedicated volume buttons
- Valerie Mk2 runs for 12 hours from a full charge using its internal Li-Ion battery
- Charge with any ordinary USB charger
- Charge and use Valerie Mk2 at the same time

For the intrepid few who've always wondered what this meant but were too busy kicking butt to ask ...



The SKAA® standard for wireless audio guarantees compatibility between all products bearing the SKAA Compatible Badge. It also guarantees product antenna performance by verifying reliable operating distance minimums have been met. SKAA transmitters work with iOS & Android mobile devices, Mac & Windows computers, televisions and any product having a line output, S/PDIF output or a headphone jack.

SKAA semiconductor components enable SKAA to be embedded in consumer audio and pro audio products. Not based on Bluetooth or WiFi, SKAA is a global compatibility standard built from the ground up specifically for audio. Learn more at www.SKAA.com

Packing List

- Valerie Mk2 SKAA Pro Microphone
- 1 meter Type-A to Type-C Charging Cable
- Protective Nylon Bag
- QR Code Card (link to Owner's Manual and more)

We like to make our products easy to use ... and Valerie Mk2 is no exception!

Still, to fully unleash the considerable capabilities of this shiny new work of art, we vehemently advise you to read this Owner's Manual. Its pages are brimming with invaluable insights, irreverent commentary, and other assorted nuggets of paradigm-altering revelation. We really poured a lot of TLC into this one and hope you love your Valerie Mk2 as much as we do.

Quick Start Guide

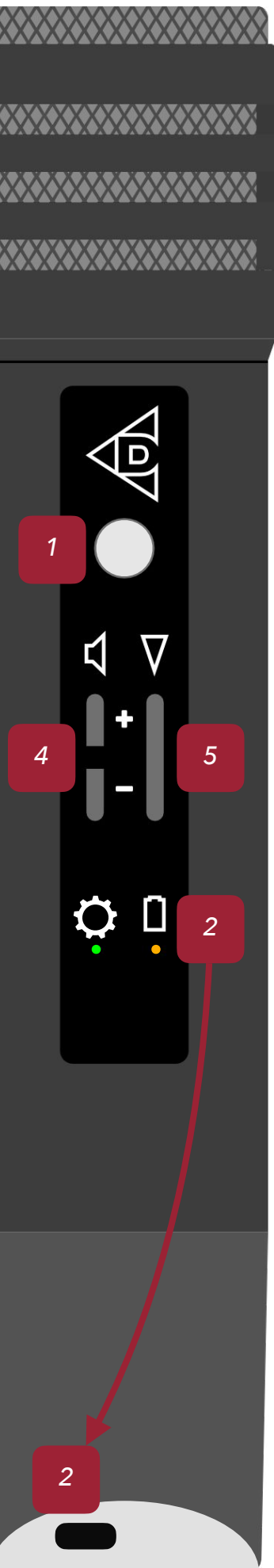

1. *Hold down the Power Button for a few seconds to turn the mic **ON** or **OFF**. The Power Button glows when Valerie Mk2 is ON. Pull down the Preamp Gain fader (slider 5) to about 50%.*

2. *Look at the Battery indicator. If it's flashing, power OFF your Valerie and charge it with any USB charger (with Type A output) and the charging cable included with Valerie. The Battery Indicator will light up during charging and will extinguish when charging is done. When mic is charged, start over from step 1.*

3. *Power ON your SKAA receiver or speaker. If it's a multi-mode speaker, make sure it's acting as a SKAA receiver (for example, select SKAA mode on Stage One or select JOIN mode on Soundboks). Refer to its owner's manual if necessary. Set your speaker's LOCAL volume to 50%. If you have more than one Speaker/Receiver, repeat this step for the remaining units.*

4. *Bond your speaker or receiver to Valerie Mk2: Double Click the Bond Button  on your SKAA Speaker/Receiver. You will see the Bond Indicator glow bright Amber once Bonded. If you have more than one Speaker/Receiver, repeat this step for the remaining units. Operate the Global Volume (+/-) buttons on Valerie – if you see the Bond Indicator on your Speaker/Receiver flashing when you do, it has successfully Bonded to Valerie.*

5. *Speak into the microphone. Say something like "I've got a Polish uncle; and a Czech one too, a Czech one too". As you do, push up the Preamp Gain fader (slider) to about 80%. The Preamp Gain affects your mic's level, but it also affects the timbre of your sound (clinical vs. warm). Adjust GLOBAL VOLUME (that's the +/- buttons on Valerie). Use GLOBAL VOLUME to change the volume of your whole speaker system. Now adjust LOCAL VOLUME on each individual Speaker/Receiver so your overall system is balanced to your liking.*

Power, Mode & Sleep

Hold down the Power Button for a few seconds to turn Valerie Mk2 ON / OFF. The Power Button illuminates either red or green when Valerie is ON.

● *In SKAA mode the Power Button will lite up green and Valerie Mk2 will feed up to 4 SKAA Receivers at 36 ms of latency*

● *In SKAA Pro mode the Power Button will lite up red and Valerie Mk2 will feed up to 2 SKAA Receivers at 19 ms of latency*

- While powered ON, change Valerie's mode by six-clicking (click the Power Button 6 times, fast). This reboots Valerie and you'll see the illuminated color of the Power Button change from green to red or vice versa.
- Once you change Valerie's mode, it will stay that way until you manually change it again. Mode is persistent, even surviving power OFF / ON.
- NOTE – Speakers/Receivers always follow the mode of the transmitter (in this case, Valerie Mk2). There's no action required on the Speaker/Receiver side when you change modes; they will follow the mode of the Transmitter automatically.

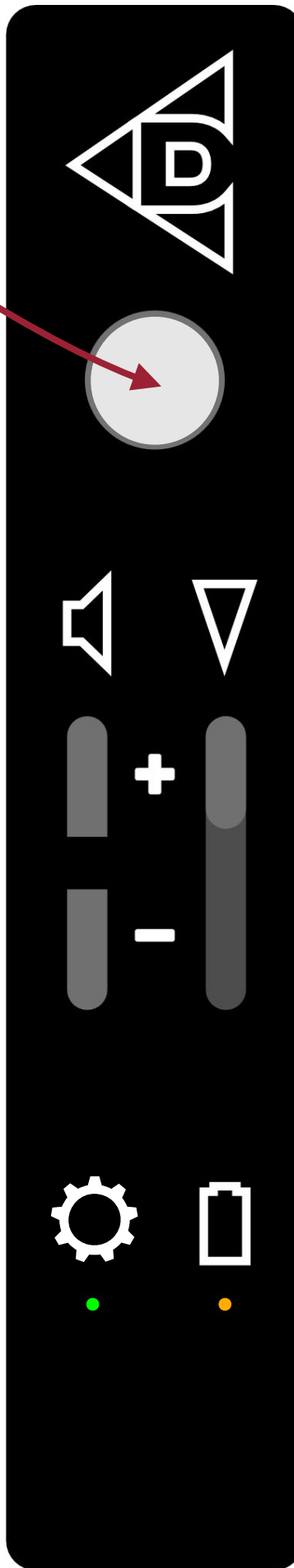

- SKAA Pro mode (red) is ideal for live PA (ie singing). For talk (speech), SKAA mode can be super useful since up to 4 Speakers/Receivers can be Bonded with no need for a mixer.
- A good rule of thumb is, use SKAA Pro mode if you have only 1 or 2 Speakers/Receivers; you'll benefit from the lower latency. When you need to Bond 3 or 4 Speakers/Receivers to your mic, use SKAA mode.
- Virtual Off (VO) is a sleep mode in which Valerie turns off its SKAA radio following a period of silence. This results in Bonds being dropped to all downstream Speakers/Receivers.
- In SKAA mode, Valerie Mk2 will go to Virtual Off state after 2.5 minutes of no audio (silence)
- In SKAA Pro mode, Valerie Mk2 will go to Virtual Off state after 20 minutes of no audio (silence)
- When in VO, Valerie's Power Button brightness will be dimmed
- If silence continues for an extended period, Valerie Mk2 will power itself OFF automatically and the Power Button will no longer be lit. If Valerie is plugged into a charger, then this auto power OFF will not happen.

Pro Tip:

You can disable the VO feature by clicking the Power Button five times, fast. The LED under the gear icon will flash 5 times to confirm. Now all Speakers/Receivers will stay Bonded to Valerie Mk2 indefinitely. Valerie will stay powered ON until you turn it off manually. The VO feature will be enabled again the next time you power ON your Valerie.

Quick Reference – Signal Path & Controls

Valerie Mk2

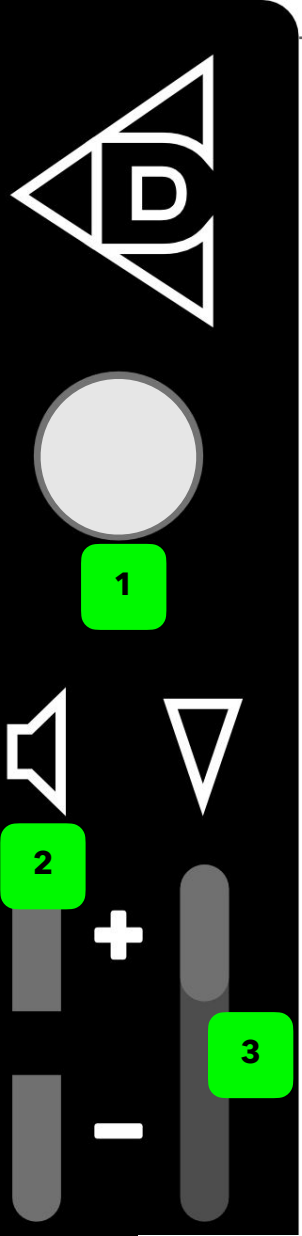
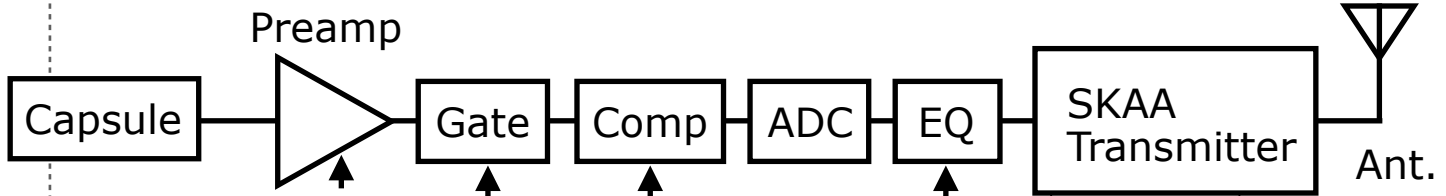

- 3**
 - Preamp Gain fader (slider)
 - Control the gain of Valerie's built-in analog preamp with this fader
 - Drive into the compressor hard or soft and change the character of your sound
- 1**
 - Double Click the Power Button to change the Fat Channel Preset
 - The Gear Indicator (4) will change color
 - See the table for a quick reference of which color represents which Preset
- 4**
- 2**
 - Global Volume (+/-) Buttons
 - Mute/Unmute Bonded speakers by 3x clicking the Power Button
- 1**
 - Remote control the volume of Bonded Speakers/Receivers
- 1**
 - 6x click the Power Button to change Valerie's Mode
 - Green Power Button = SKAA
 - Red Power Button = SKAA Pro

Power Button	Function
Hold	Power Valerie Mk2 ON or OFF
1x click	Fuel Gauge check – count battery LED flashes
2x click	Change Fat Channel Preset (see color table)
3x click	Mute/Unmute all Bonded Speakers/Receivers
4x click	-
5x click	Disable Virtual Off (VO = sleep) function
6x click	Toggle Mode (SKAA or SKAA Pro)

	Preset	Description
	Gab	Talk – gentle gate & EQ A
	Hawk	Talk – aggressive gate & EQ A
	Chase	Sing – fast/hard compression & EQ B
	Silk	Sing – slow compression & EQ B
	Catch	Sing – fast/hard compression & EQ C
	Goo	Sing – slow compression & EQ C
	None	No Gate / No Compressor / No EQ

Remember to add Valerie to the Green List of the speakers you're using; see the SKAA Receiver User's Guide later in this manual



Bonded SKAA Speaker(s)/Receiver(s)

Volume Control & Preamp Gain

- Speaker/Receiver Bond Indicators will slow flash when they're muted
- Valerie's GLOBAL Volume control buttons provide 30 volume steps from 0 to full
- The Bond Indicator on all Bonded receivers flashes when you use the +/- buttons on Valerie
- This flashing tells you the receiver is Bonded to Valerie and volume control data is flowing
- Flashing stops when you reach the bottom (0) or top (30)
- NOTE: many speakers and receivers also use 30 steps for their LOCAL Volume controls
- Both GLOBAL and LOCAL volumes matter. For example if the GLOBAL volume is 50% and the LOCAL volume is 80%, the speaker's actual volume = $0.5 \times 0.8 = 0.4$, or 40%

Global Volume Buttons (+/-) remote control the volume of all Bonded speakers and receivers

- To balance out your speaker system, start by reducing your Global Volume to around 50% (15 clicks down from full up).
- Then pick the speaker which needs to be loudest and set its Local Volume to full up. Set the remaining speakers' Local Volumes to your liking.
- Now control whole system from Valerie's +/- buttons

Mute or Unmute all Bonded receivers with 3x clicks of the Power Button

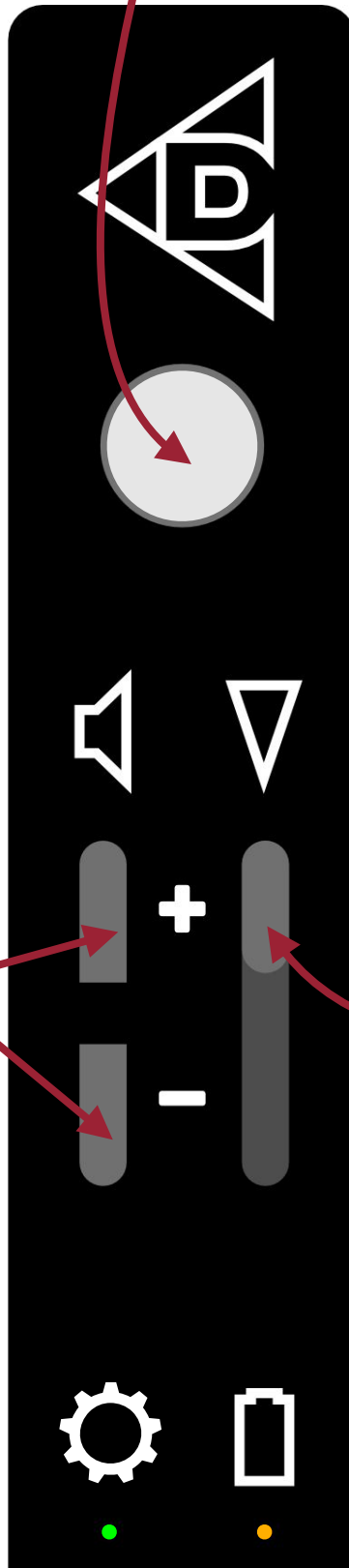

- Valerie has a built-in analog mic preamp. The preamp gain is controlled by a dedicated fader. It's the slider on the right hand side of the user interface.
- This fader is useful for several things. But it's not intended for setting the volume level of your vocals. For that, use the Global Volume Buttons on the left.
- The fader's prime purpose is to make sure a healthy (but not too strong) vocal signal arrives at the ADC (analog to digital converter). See the previous page.
- You'll want to set the fader up higher, around 90%, for soft talkers and lower, around 50%, for loud talkers. In a loud environment such as a trade show, people will naturally talk louder. So a low fader position will work better in that situation, too.
- The Preamp gain also affects how hard your vocal is hitting the compressor in Valerie's DSP. A higher fader means your vocal will be more compressed. A lower fader will allow for more dynamics in your vocal.

Pro Tip: If you hear distortion in the vocal audio, pull down the Preamp Gain Fader a little bit. You may be overdriving Valerie's ADC with a signal that's too strong.

The Preamp Gain fader is NOT for volume control – it has a completely different purpose

About Feedback: If you hear feedback, pull down the Preamp fader to instantly stop it. Then make sure your mic's grille (capsule) is pointed away from your speakers and push the fader back up. Also, you can try a different Fat Channel Preset. Depending on your exact environment, some Presets will suppress feedback better than others. And note SKAA mode is more immune to feedback than SKAA Pro mode.

Battery, Charging & Fuel Gauge

- Valerie Mk2 runs 12 hours from a full battery
- Click the Power Button to activate the Fuel Gauge and count the number of times the Battery Indicator flashes. Check the table below for the meaning.
- When 3% battery energy remains, the Battery Indicator will begin to flash slowly indicating Low Batt state. That's your cue to charge Valerie.
- When the battery is fully depleted, Valerie Mk2 will power itself OFF automatically
- Any USB power adapter will charge Valerie Mk2 including ordinary mobile phone chargers
- Fast charging is supported. A charger capable of at least 2 Amperes (2 A) will charge Valerie in 2.5 hours from empty.
- Valerie's Type C jack is for POWER ONLY. If you plug Valerie into your computer, nothing magical will happen except Valerie's battery will become fuller.
- Li-ION batteries benefit from being charged BEFORE they're fully depleted – getting into this habit will extend your battery life

Batt Indicator	Meaning
1 Flash	Fuel Gauge – 25% Batt Energy remains
2 Flashes	Fuel Gauge – 50% Batt Energy remains
3 Flashes	Fuel Gauge – 75% Batt Energy remains
4 Flashes	Fuel Gauge – Battery is Full
Slow Flash	3% or less Battery Energy remains
Solid ON	Battery Charging in Progress
OFF	(during charging) means Charging Complete

Pro Tips

- **Many other USB power sources can also be used to charge Valerie Mk2. For example computers, cars, power banks, TVs and even some mixers and speakers with Type A ports. Just make sure Valerie's Battery Indicator is glowing solid when you plug into any power source. This tells you charging power is actually getting to the battery. Depending on the capabilities of the specific source, charging may take more time than with a good charger (some may take 10 hours or more).**
- **You can use Valerie Mk2 while you're charging it. But be aware that chargers, power banks, computers and other USB power sources are notoriously noisy. If you plan to charge Valerie during a real gig, make sure you test it first and convince yourself that the power source's noise is not audible in your vocal audio.**

While Valerie Mk2 is powered ON, Click the Power Button once to activate the Fuel Gauge

The Battery Indicator flashes a number of times when Fuel Gauge is activated

Charge Valerie by plugging the included Charging Cable into this jack. Connect the other end to any USB charger and plug it into AC power.



Fat Channel Presets

The Gear 
Indicator always
displays the color of
the active Preset

- Double Click the Power Button to rotate through the Fat Channel Presets
- Each Preset is a different combination of Gate, Compression and EQ
- Preset 7 (white color), not shown in the table below, is a **NONE** Preset –it has no gate, no compressor and no EQ. Note that the Preamp Gain fader continues to work. Use Preset 7 if you're feeding, say, a mixer, and you want to use the Gate, Compression and EQ on the mixer instead.
- Valerie will remember your Preset –even if you Power Valerie OFF, the same Preset will be active the next time you Power Valerie ON
- Presets 1 and 2 share the same EQ. Likewise for 3/4 and 5/6.
- See descriptions and EQs for each Preset in the table below

Preset 1 Gab

Talk for normal environments. There's a gate, but it's relatively easy to activate with no need to shout.

Preset 2 Hawk

Talk for loud environments. Turn down the Preamp Gain fader a bit for this one. You'll need to speak up to activate the gate.

Preset 3 Chase

Sing with aggressive 5:1 compressor that grabs and lets go fast. Pull down Preamp for less aggressive compression.

Preset 4 Silk

Sing with a 4:1 compressor that lets your initial transients pass before activating and takes a while to let go. There's no gate.

Preset 5 Catch

Sing with aggressive 5:1 compressor that grabs and lets go fast. Pull down Preamp for less aggressive compression.

Preset 6 Goo

Sing with a 4:1 compressor that lets your initial transients pass before activating, and takes a while to let go. There's no gate.

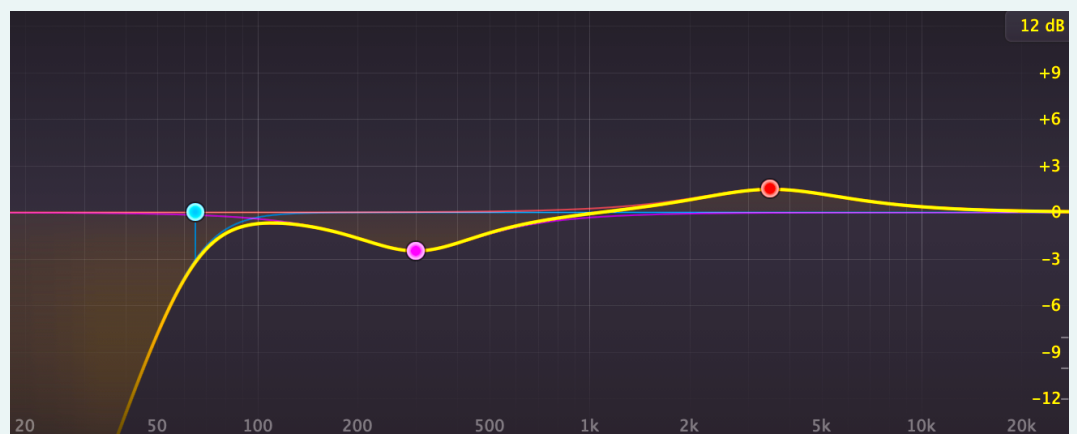
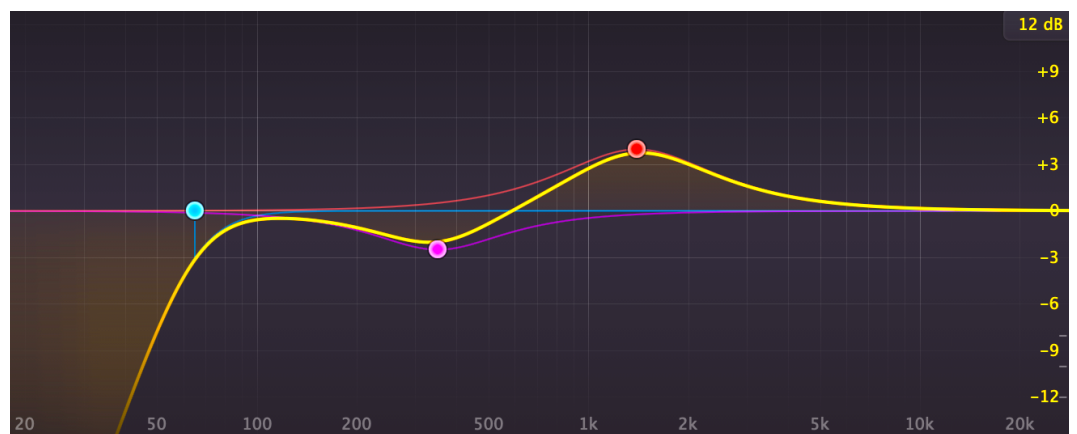

Specifications

Parameter	Conditions	Value
Battery type	-	3500 mAh, 3.65 V, 18650 Li-Ion cell
Battery life	From Full	12 hours
Charge time	From Empty	2.5 hours (fast charging)
Reliable range	-	25 meters
SKAA transport latency	Digital to Digital	36.72 +/- 1.5 samples
SKAA Pro transport latency	Digital to Digital	19.39 +/- 1.5 samples
Antenna type	-	Eleven Engineering Model B2
Max RF output	-	20 dBm
Wireless Protocol	-	SKAA OS 2.7 – works with all receivers running SKAA OS 2.1 or newer
RF channels	-	49 channels, 3MHz bandwidth each
RF band	-	2400 - 2483 MHz ISM band
Mass / Weight		300 g (0.66 lbs)
Dimensions (W × L × H)		20 × 3.5 × 3.5 cm

Wondering how to get Streetheart and other SKAA receivers, speakers and headphones to Bond to your brand new Valerie Mk2?



... discover the awesome power of the Bond Button, found on all SKAA Receivers, in the next 2 pages

Subscribe to SKAAsound channel on YouTube for HOW-TO vids!

*Need Receivers, speakers or accessories?
SKAAstore.com has what you need!*











Join us on social media ... visit SKAA.com and follow the links

support: dillingerlabs.com/contact









SKAA® RECEIVER USER'S GUIDE

Each SKAA receiver uses a *Green List* to remember your *favourite* audio sources (SKAA transmitters). A Green glowing Indicator on your receiver means you are listening to a favourite, or hunting for one. You can also *explore* to find new transmitters—an Amber Indicator means you are *exploring* for transmitters which are not on your Green List. The  Bond Button on your receiver lets you select which audio source (SKAA transmitter) you're listening to.







Essentials

 <i>Button</i>	<i>Command</i>	<i>Indicator</i>
Hold a few seconds	<u>Add / Delete</u> Manually add / delete the current transmitter to / from your Green List	 to  = Added  (flash) = Deleted
-	<u>Auto Add</u> SKAA will automatically add the current Amber transmitter to your Green List if you listen to it for 30 minutes	 to  = Added
1 Click	<u>Green Mode</u> Rotate through your list of <i>favourite</i> transmitters (Green List) — when a favourite transmitter is found, the search stops and audio plays from that transmitter	 (dim) = Hunting  (flash) = Next one  (bright) = Bonded
2 Clicks	<u>Amber Mode</u> <i>Explore</i> for new, unknown transmitters (ones which are not already on your Green List)	 (dim) = Hunting  (bright) = Bonded

More Commands

 <i>Button</i>	<i>Command</i>	<i>Indicator</i>
3 Clicks	<u>Mute</u> do again to Unmute; any Click command will first Unmute and then do its function	 ,  or  = Muted (slow flash)
4 Clicks	<u>Red Mode</u> If you have 2 or more transmitters on your Green List, power on just the one you want to hear and it plays automatically.	 (dim) = Hunting  (bright) = Bonded
6 Clicks	<u>Factory Reset</u> Clear Green List. Start Over!	 (flash) = Reset Done
Hold during power on	<u>Make a Cluster of Receivers:</u> <ol style="list-style-type: none"> 1. Power off all transmitters and receivers 2. Power on the Master receiver while holding down its Bond Button—hold the button down until the Indicator begins to flash Red 3. With the remaining receivers within 3 meters of the Master receiver, power on the first one, wait for its Indicator to flash Red and then power on the second one; continue until all of them are powered on 4. Once all of the Indicators stop flashing (turn solid Red), power off all of the receivers 	 (flash) = Receiver has entered 'Cluster Up' mode  (bright) = The Cluster has been successfully made

QUESTIONS AND ANSWERS

Question	Answer
How does the Green List work?	You can store up to 10 SKAA transmitters on your Green List. These are your “favourite” audio sources. Every time you add a transmitter, it is assigned the first open spot on the Green List. When you single click the  Bond Button, the receiver hunts through the Green List much like a car radio hunts for radio stations when you press seek. If the Indicator is dim Green and flashes every few seconds, this tells you the receiver is hunting through the Green List. Say you have 5 transmitters on your Green List; your receiver will hunt through the list one by one: 1, 2, 3, 4, 5 and then back to 1 and so on. The dim Green Indicator flashes every time the receiver moves to the next spot on the list. This hunting goes on for up to 1 minute. If your receiver doesn't find any of your favourite transmitters, it stops hunting and just waits for the last bonded favourite. If your receiver does find one of your favourite transmitters, the hunting stops, the Indicator turns bright green, and your receiver starts playing audio from that favourite. A dim Green Indicator that is NOT flashing means the receiver is just sitting on one spot, waiting for a specific favourite transmitter to show up.
How do I bond with a specific Green transmitter?	Play audio from your source device and ensure it has a SKAA transmitter connected. Click the  Bond Button on your receiver. The receiver hunts through the Green List, flashing the Indicator as it goes. Once your receiver finds one of your favourite transmitters, it bonds to it and plays audio from that transmitter. If that isn't the transmitter you wanted, click the Bond Button once more. Repeat until your receiver bonds with the transmitter you want and you're hearing the correct audio playing.
How do I select transmitters if I can't reach my Bond Button?	Say you want to put your receiver on a high shelf where you can't reach the Bond Button easily. First, set up your Green List: add all of the transmitters you'll want to use. Then 4-click the  Bond Button to enter Red Mode. Now put the receiver up on the high shelf. Power on just one of your transmitters and power off all others. The receiver automatically bonds to the transmitter that's on.
How do I delete a transmitter from my Green List?	Factory Reset (6 Clicks of the Bond Button) clears the Green List and lets you start over from scratch. If however, you'd like to delete just one transmitter from your Green List, first bond your receiver to the transmitter you wish to delete. See the section above: How do I bond with a specific Green transmitter? . Once you are bonded to it, hold down the  Bond Button for a few seconds until you see the Indicator flash Red –this Red flash means the transmitter has been deleted.
What is a Cluster?	Clusters are an optional convenience for “power users”. A Cluster is several SKAA receivers behaving as one product. A left & right speaker pair, for example, or a sound bar and subwoofer.
What is the Master receiver?	In any Cluster, there is a single Master receiver, and all of the other receivers in the Cluster follow its behaviour. You can control the entire Cluster by operating the  Bond Button of the Master. A receiver must have a physical Bond Button in order to become the Master.
How do I “uncluster” several receivers?	Do the Make a Cluster of Receivers procedure once for each receiver, but omit Step 3. Do them one at a time. This gives each of the receivers a functioning  Bond Button, and each of them will thereafter operate independently.
What are some tips for making Clusters?	Each step in the Make a Cluster of Receivers procedure has a 10-second time limit. When you see the Master's Indicator start to flash Red, you have 10 seconds to power on the next receiver. When that receiver's Indicator starts to flash Red, you have 10 more seconds to power on the next one, and so on.
Why does only one of my Bond Buttons work?	When you make a Cluster from several receivers, the first one powered on in the Make a Cluster of Receivers procedure becomes the Master of the Cluster. Only the Master's  Bond Button works because a Cluster uses just one Green List –the Master's Green List. The Bond Button of each of the other receivers will work only for the Mute / Unmute function (3-Click of the Bond Button).
Can any group of receivers be made into a Cluster?	No. The receivers must be members of the same product family. If they are not, the Make a Cluster of Receivers procedure won't work. This is because only receivers which were designed to work together (as a single product) can be made into a Cluster.

Important Information

Read this information carefully. Failure to follow these safety guidelines may result in personal injury or user dissatisfaction.

1. Never store or operate Valerie Mk2 near a heat source.
2. Do not charge Valerie Mk2 during electrical storms.
3. Connecting Valerie Mk2 to audio sources at loud volumes always comes with the risk of hearing loss. Use caution when setting your listening levels.
4. Any disassembly of your Valerie Mk2 will void your warranty.
5. The soft carrying bag (included) protects Valerie Mk2 from damage, extending its life.

This Owner's Manual is being continuously improved with the most up-to-date and accurate information on Valerie Mk2. Please check our [website](#) for the most recent version. Have questions or comments about Dillinger Labs products? We want to hear from you! Reach out to us [here](#).

Check out SKAA's [YouTube channel](#) for great how-to videos.



the Sweet Hookups

- We're sure you're already thinking of how to integrate your brand new Valerie Mk2 into your existing setup. But in case you're needing some inspiration, we've listed a few of our favourite ways to use Valerie Mk2 here.
- You can use these as a starting point and add/subtract to taste
- If you're scratching your head on how you're going to pull off that DJ gig you got roped into doing because your co-worker's cousin is getting married and "they'd love someone who can really throw down" ... you'll find plenty of ideas below.

Legend

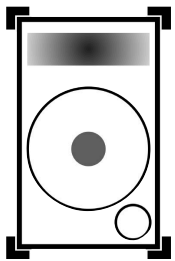

powered wired speaker

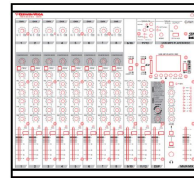

Cerwin Vega SKAA Pro Mixer



Death From Above

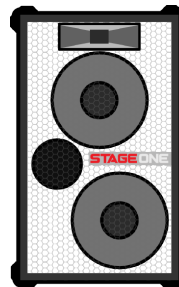

Electrotec Stage One

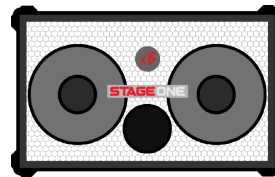

Electrotec Stage One XB

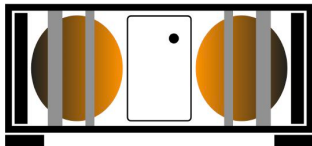

Death From Below Mk2



Valerie Mk2

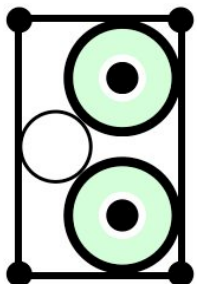

Soundboks 3, 4, Go, or Mix



Streetheart



Dani

Contents

Hookups	Use Case
1-26	Live Performance
27-36	Studio
37-44	Pro DJ
45-52	Deckless DJ Rigs
53-60	Home
61-70	Creator



LIVE PERFORMANCE

01

Easiest wireless mic ever

Valerie Mk2

Death From Above

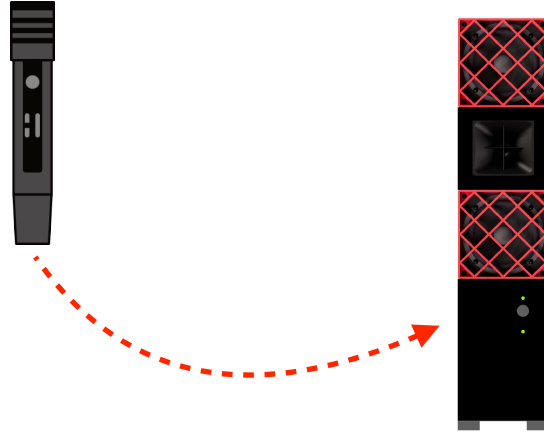

02

Extra coverage

Valerie Mk2

Death From Above

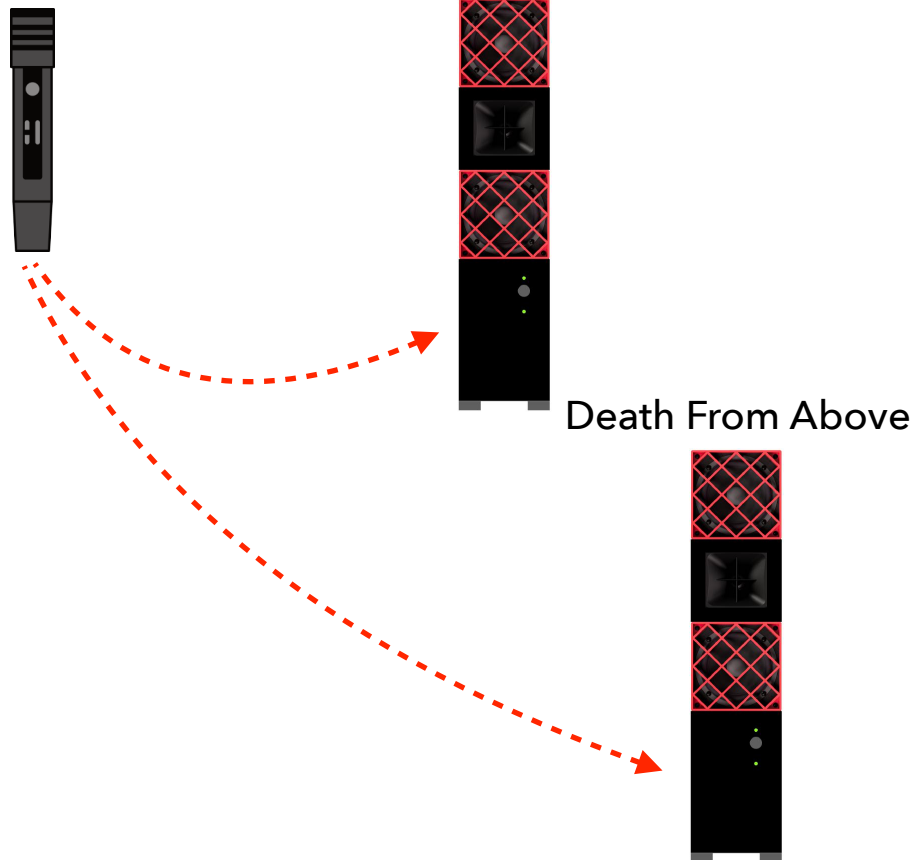

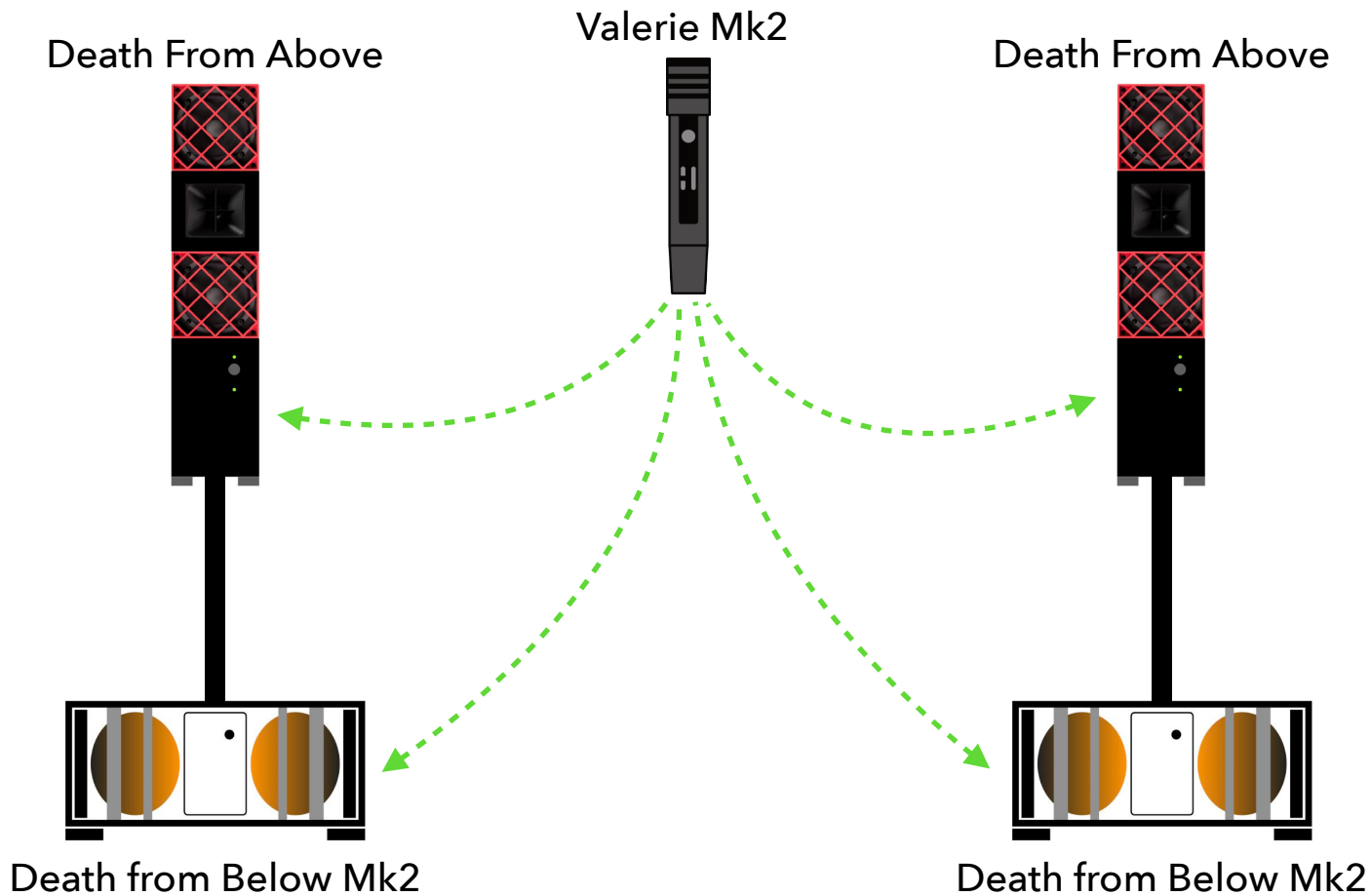
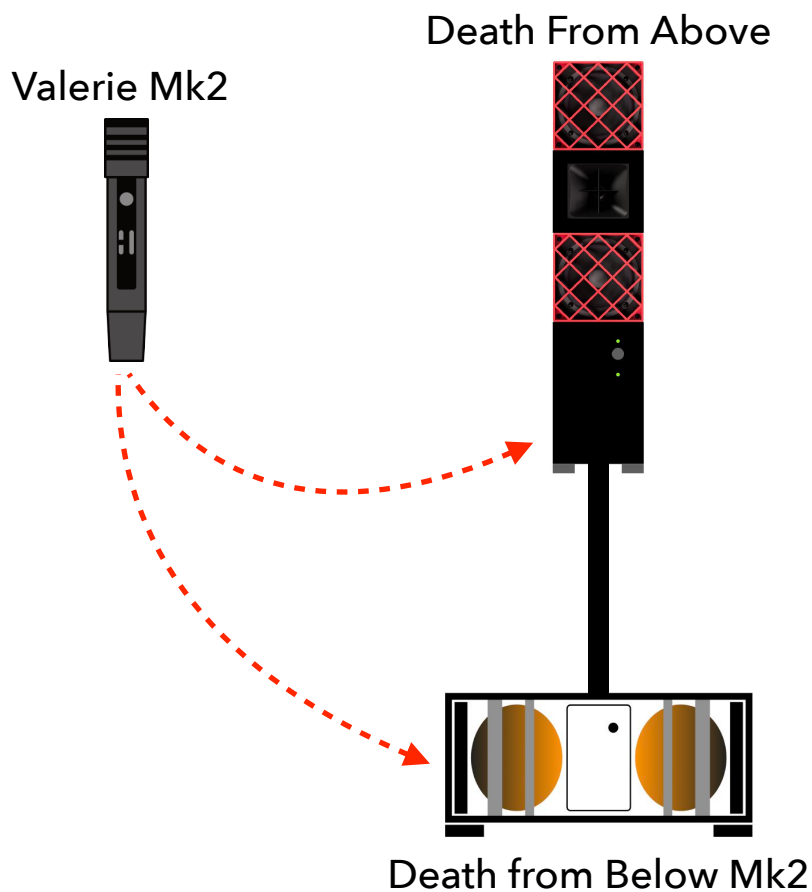

05

Use with any SKAA Receiver...

Valerie Mk2

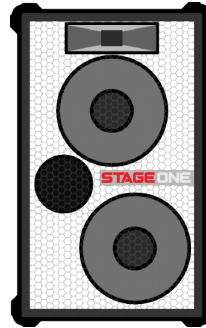
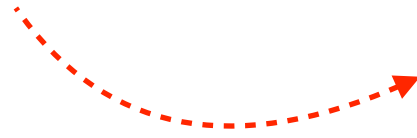

Electrotec
Stage One

06

...including Electrotec Stage One and XB

Valerie Mk2

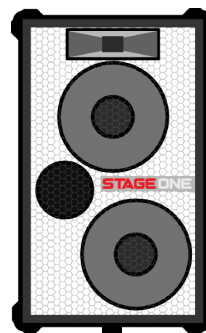
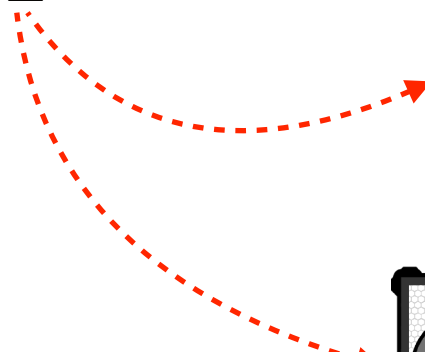

Electrotec
Stage One

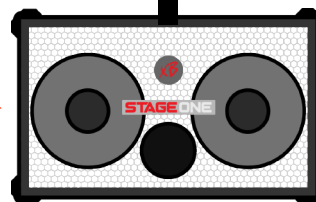

Electrotec
Stage One XB

07

With Wet Sounds WS-L...

Valerie Mk2

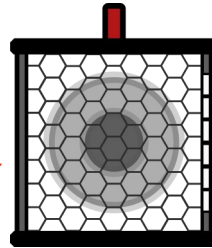
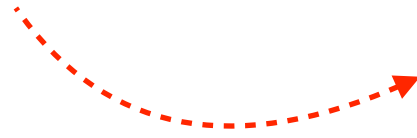

Wet Sounds
Portable WS-L

08

...or your favourite Soundboks

Valerie Mk2

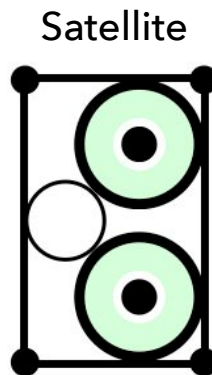

Soundboks
3, 4, Go, or
Mix

Valerie Mk2

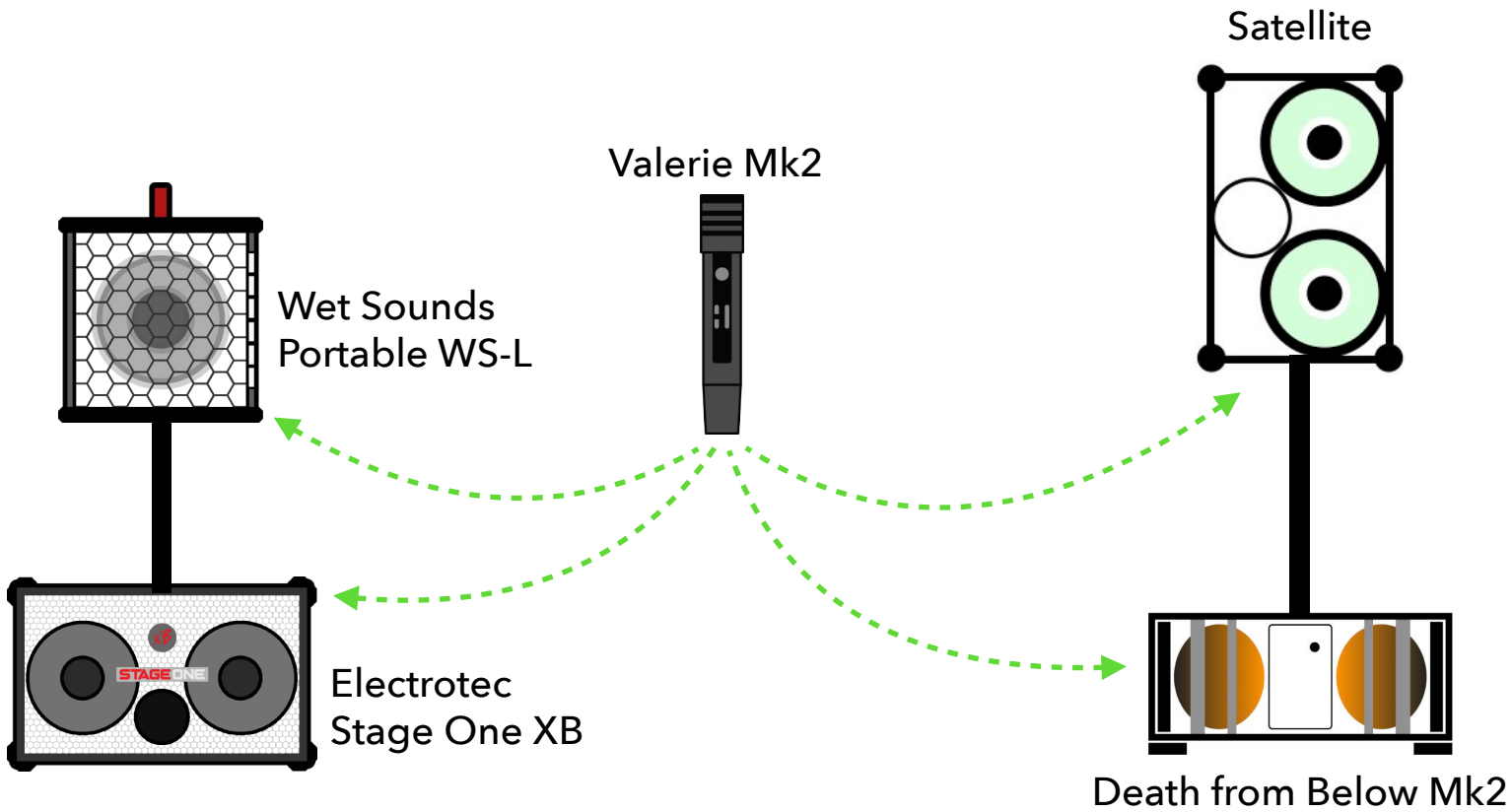
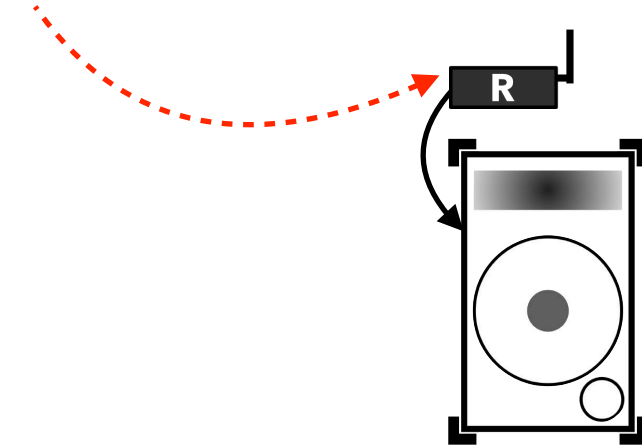

Satellite

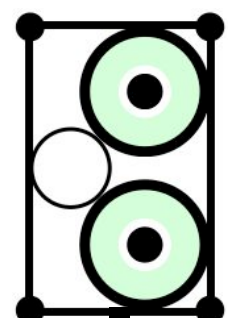

Valerie Mk2



Wet Sounds
Portable WS-L

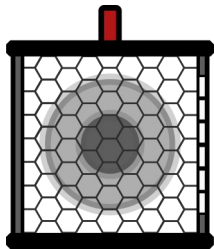

Electrotec
Stage One XB

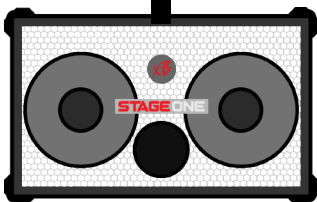

Death from Below Mk2

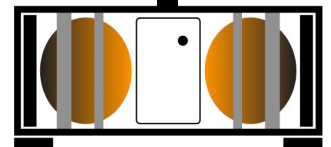

11

Take advantage of K Mode or Play All Mode

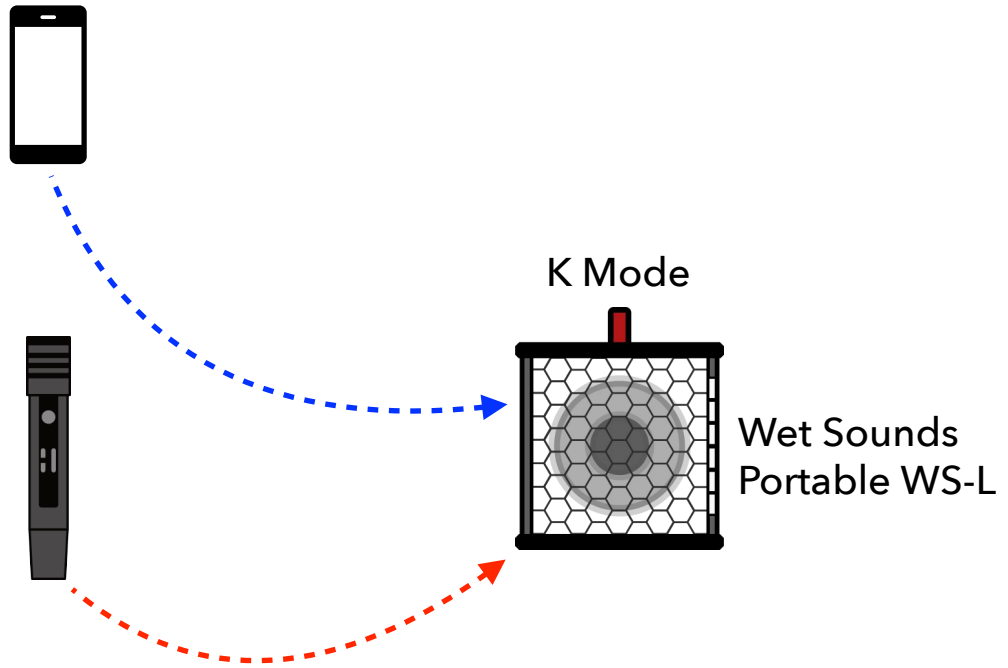

12

Add some extra coverage

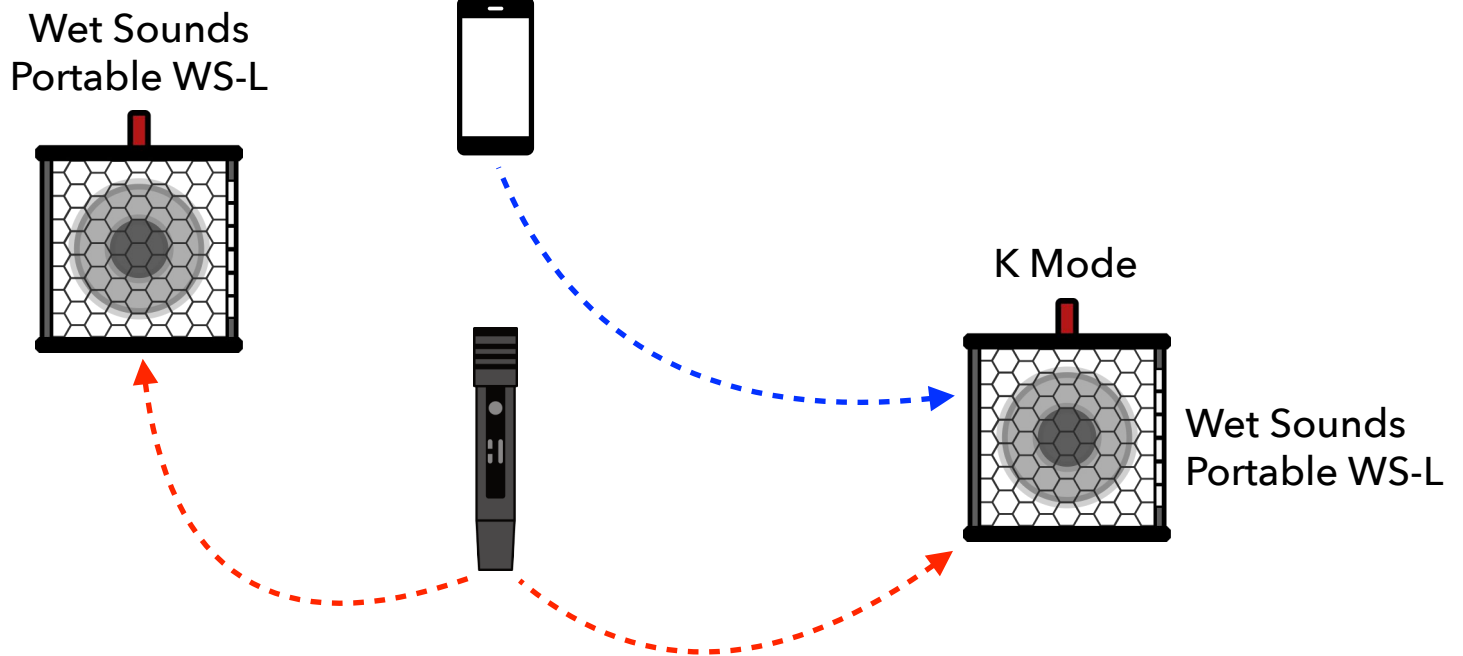

13

Solo acoustic sets have never been this easy

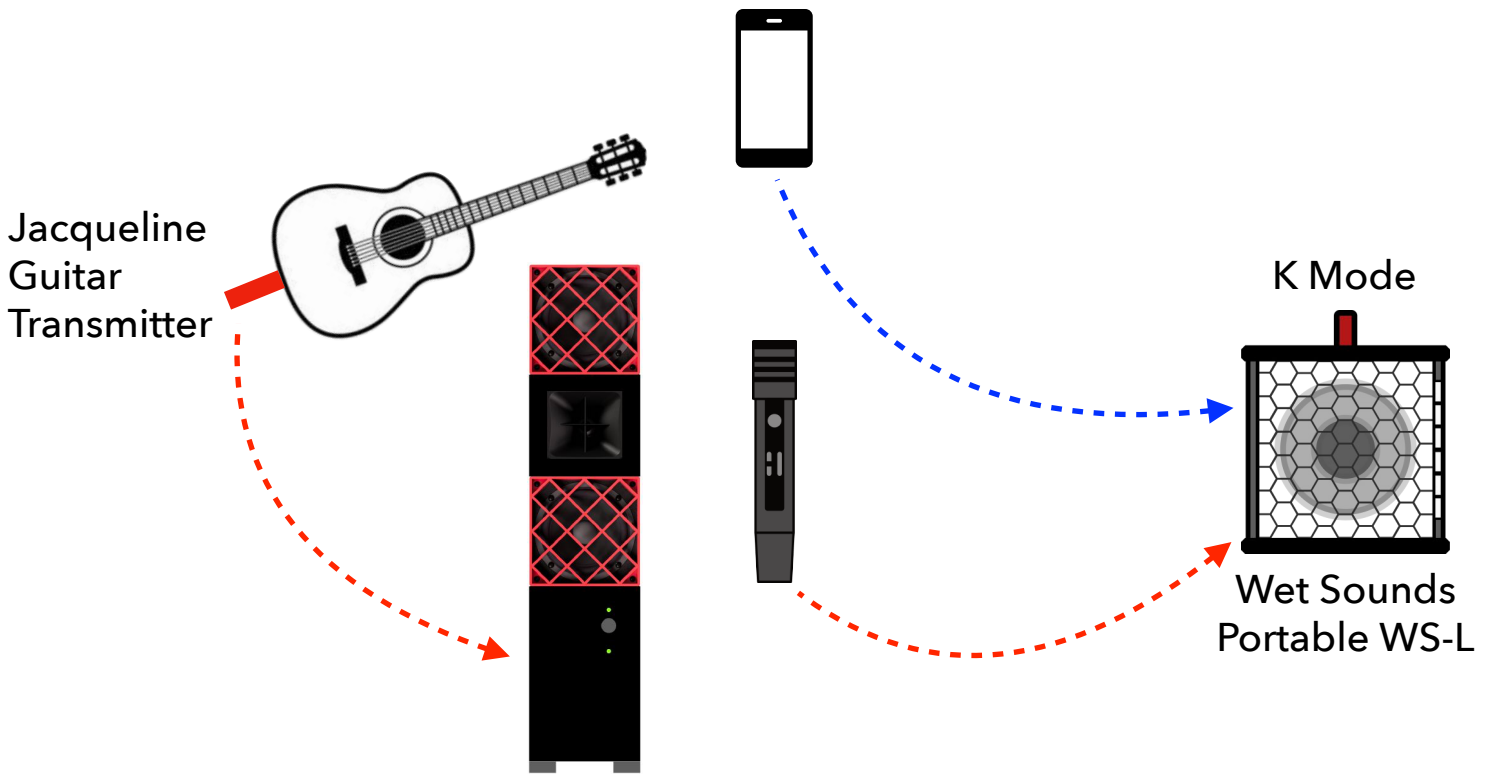

14

Or a duet!

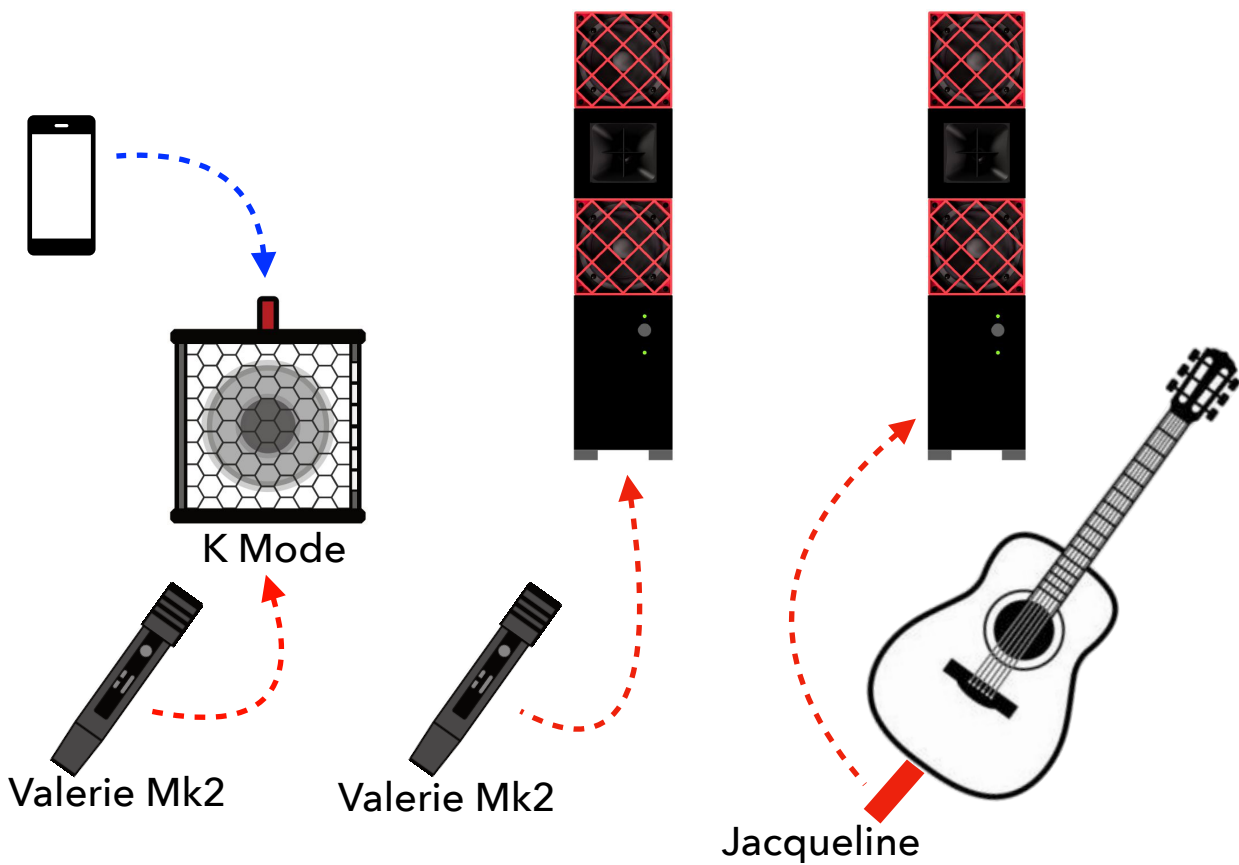

15

Trio band setup

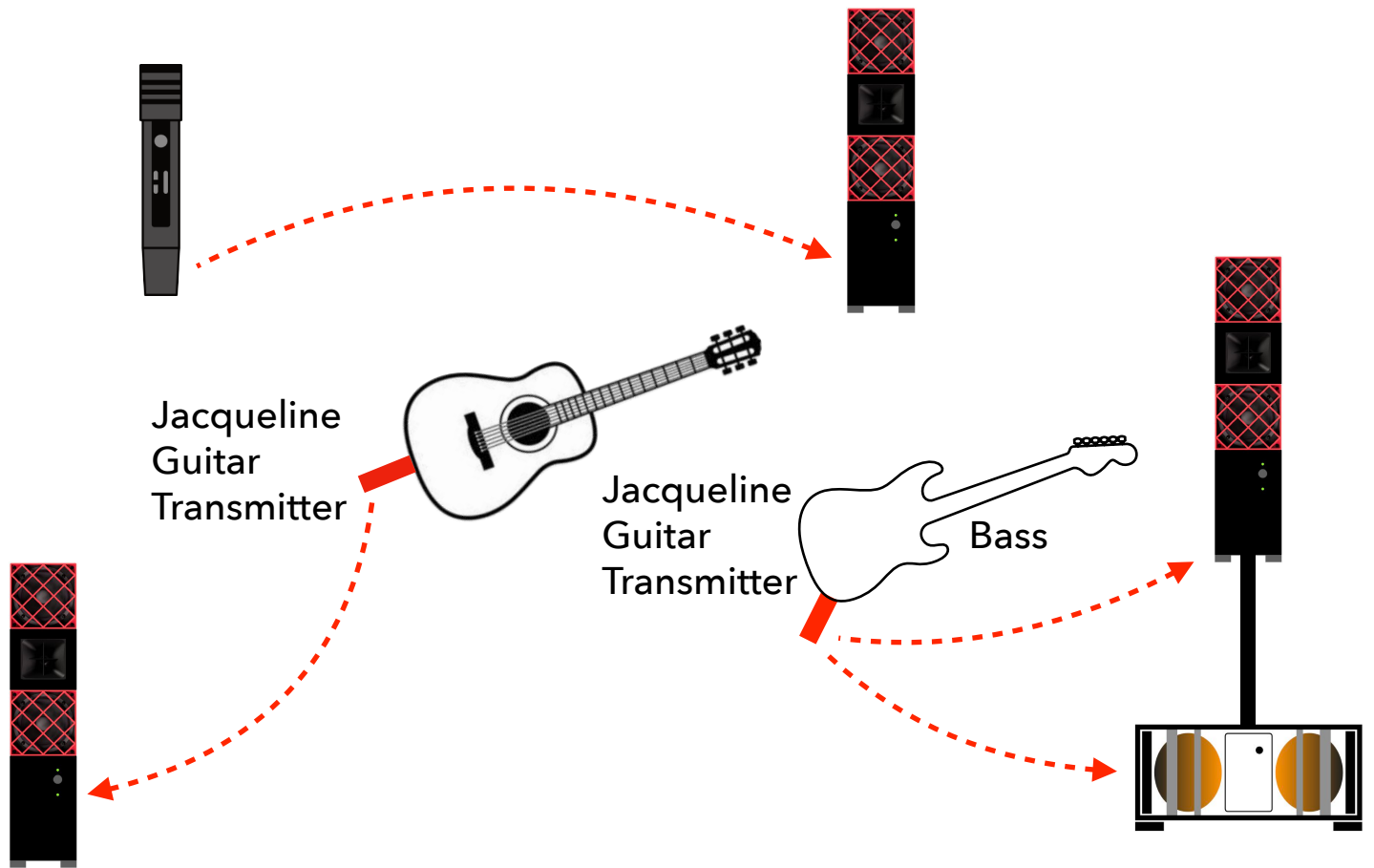

16

With a backing track

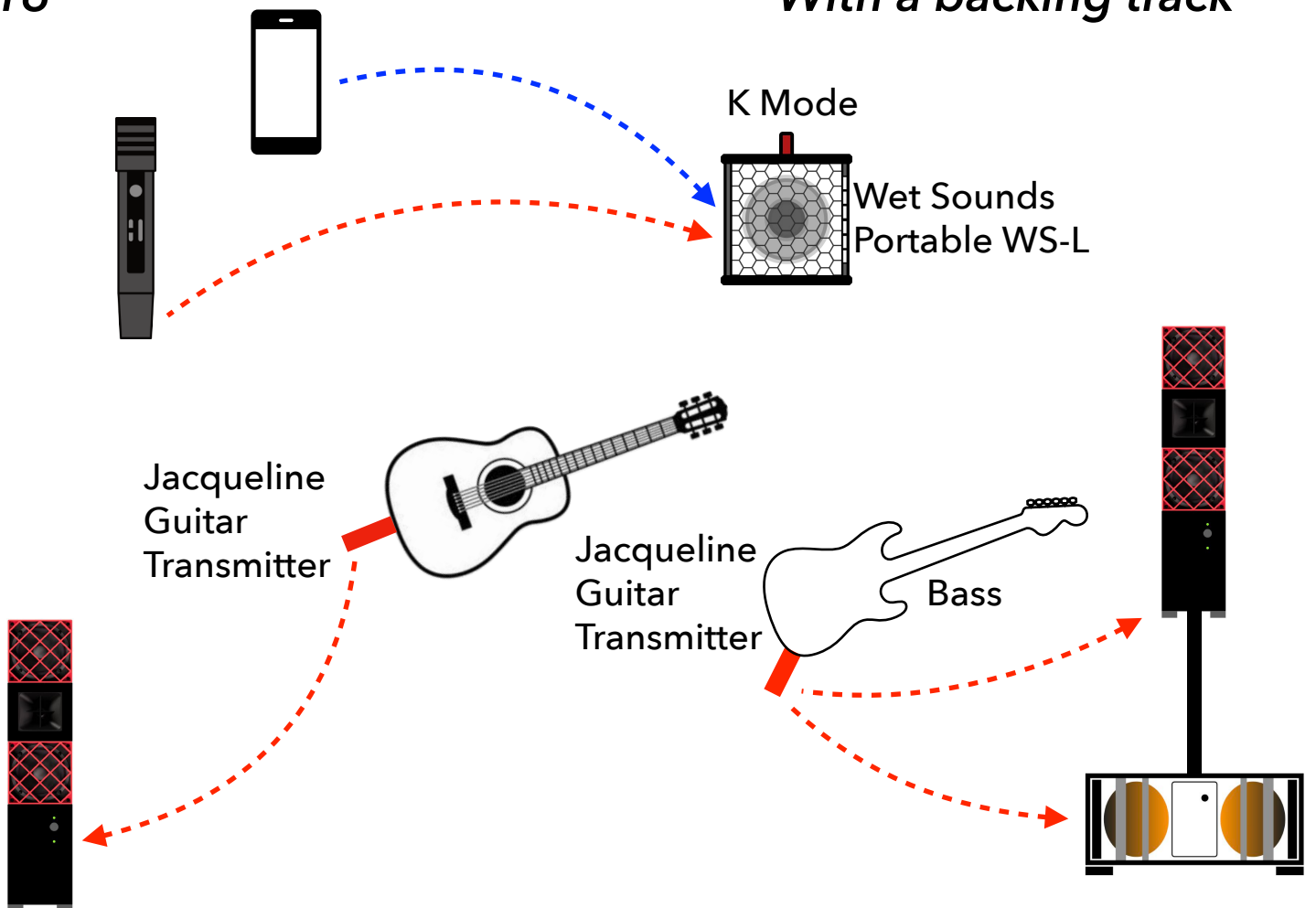

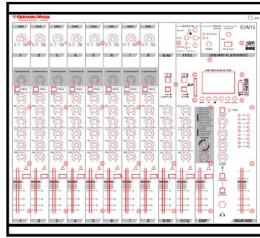

Cerwin Vega
SKAA Mixer

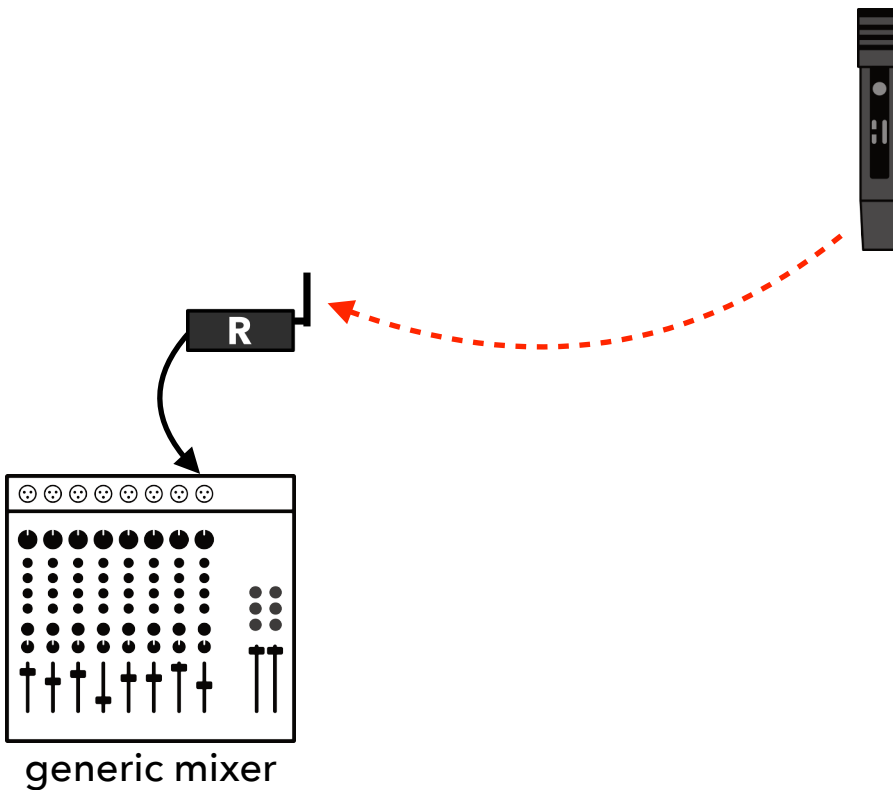
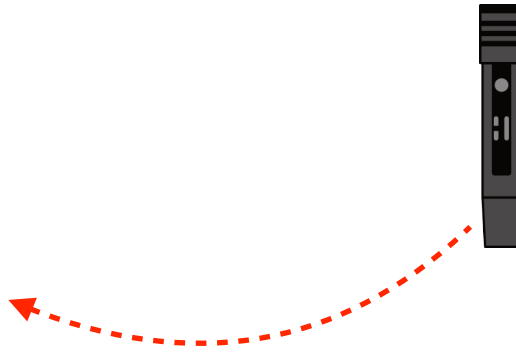

generic mixer

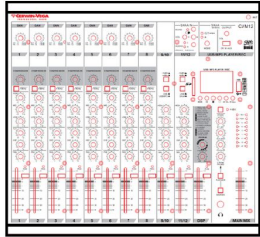

Cerwin Vega
SKAA Mixer

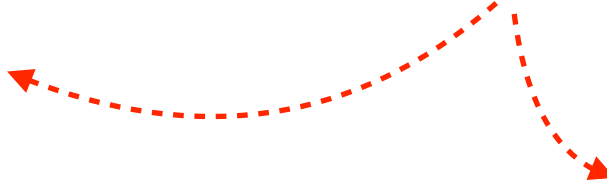

DFA as a
monitor wedge

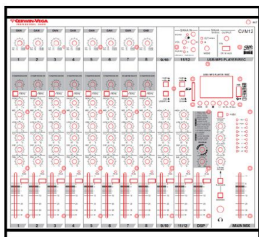

Cerwin Vega
SKAA Mixer



IEMs or
Headphones



Rush



21

Solo busking

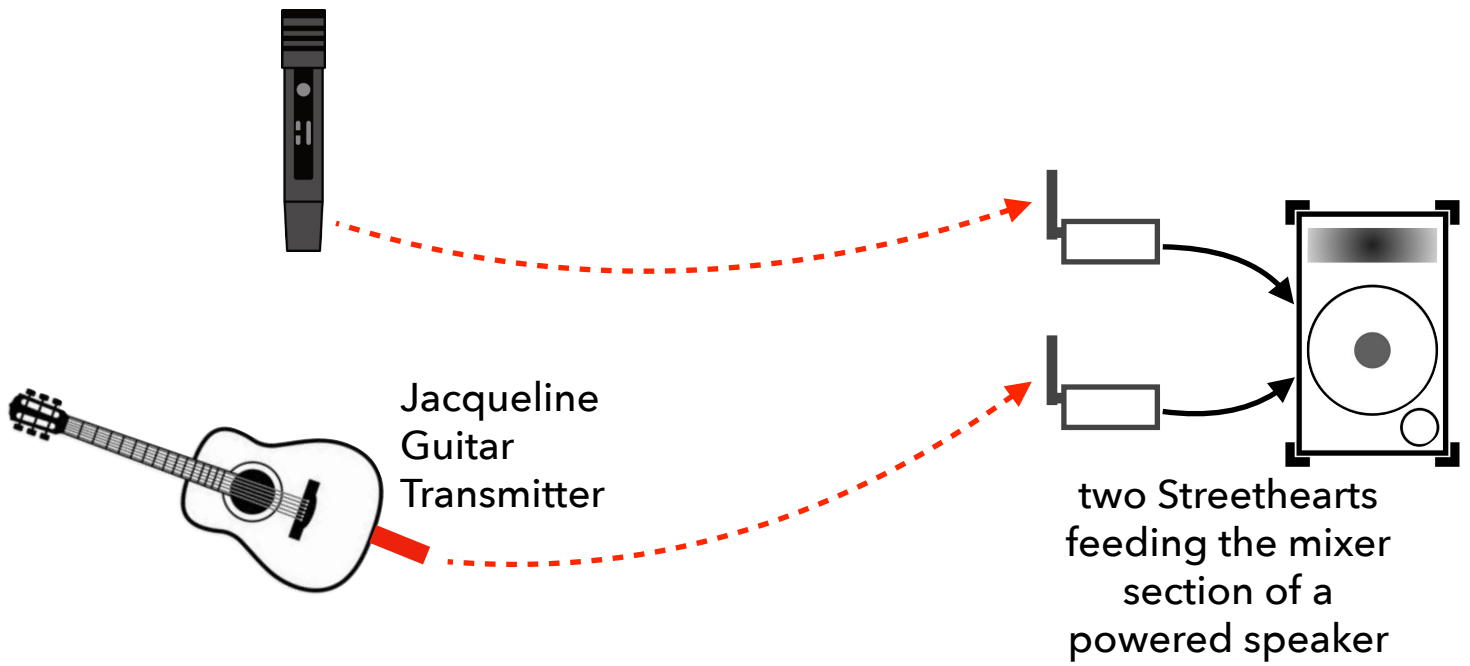

22

Solo busking II

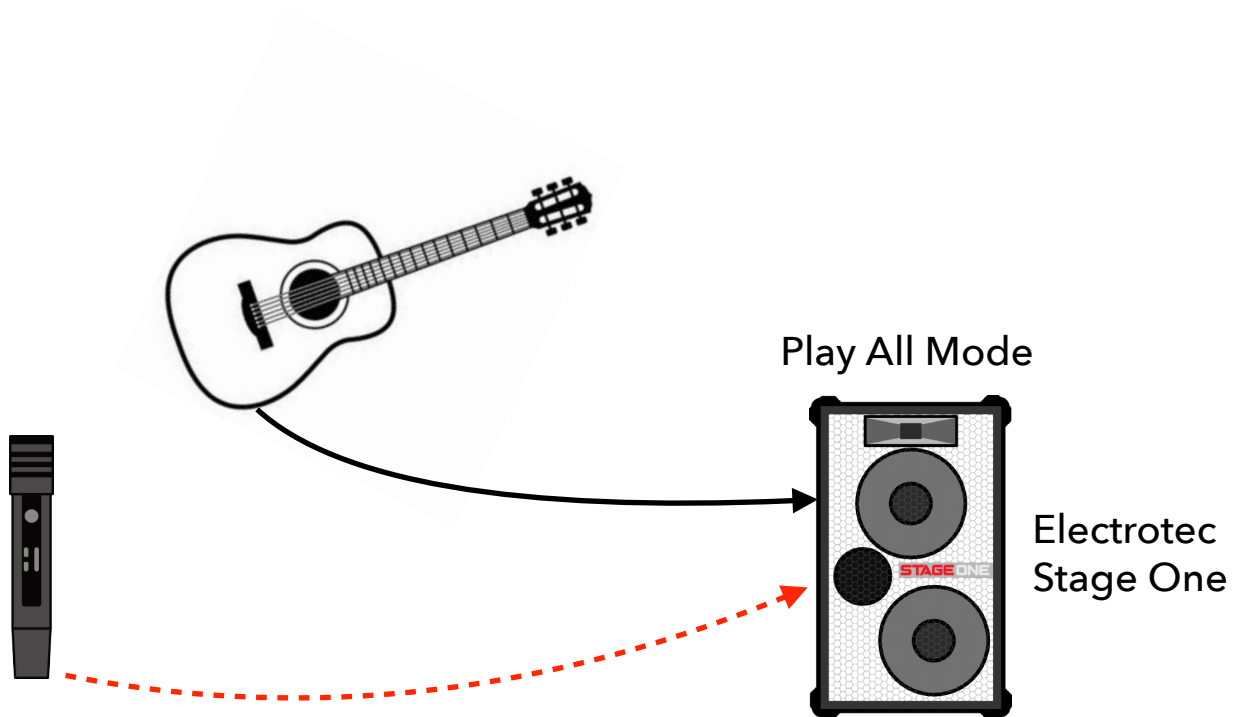

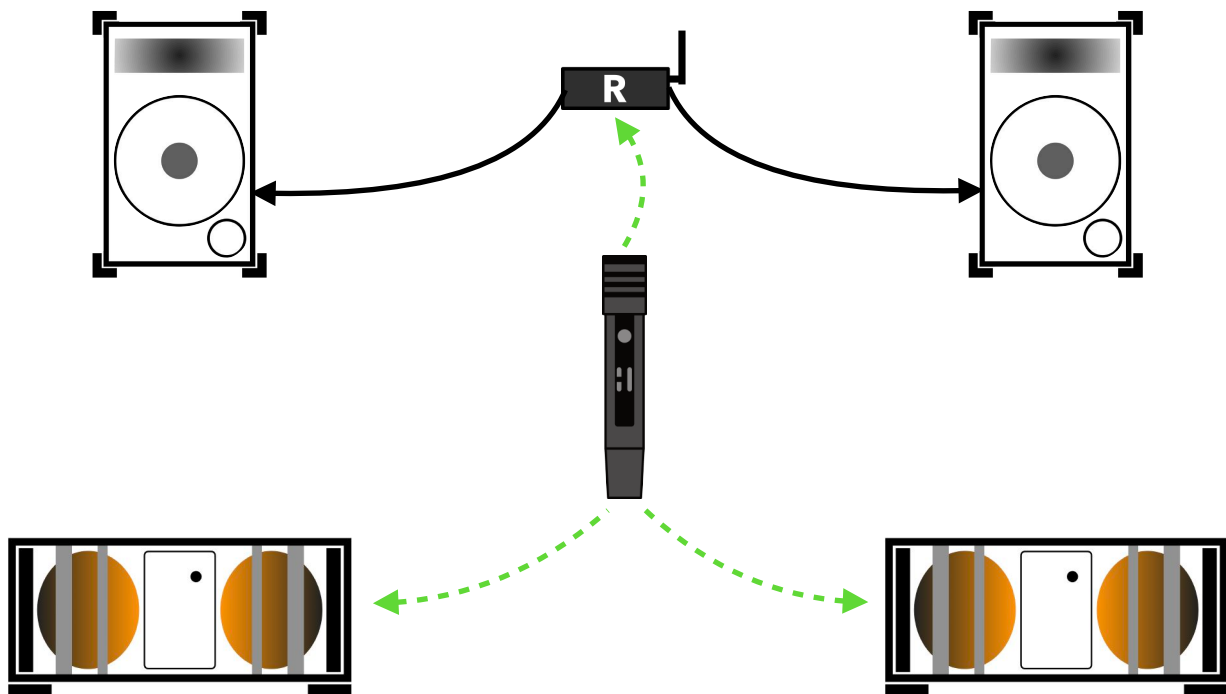
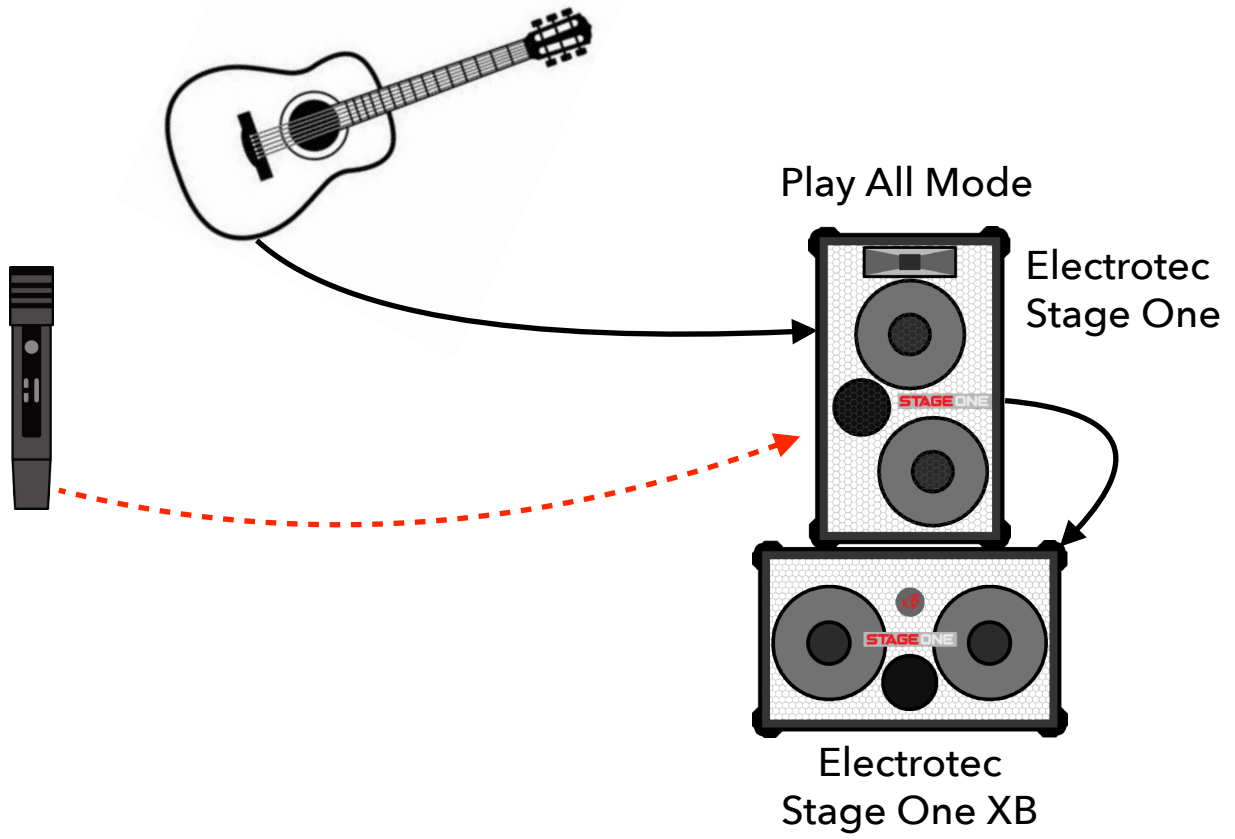

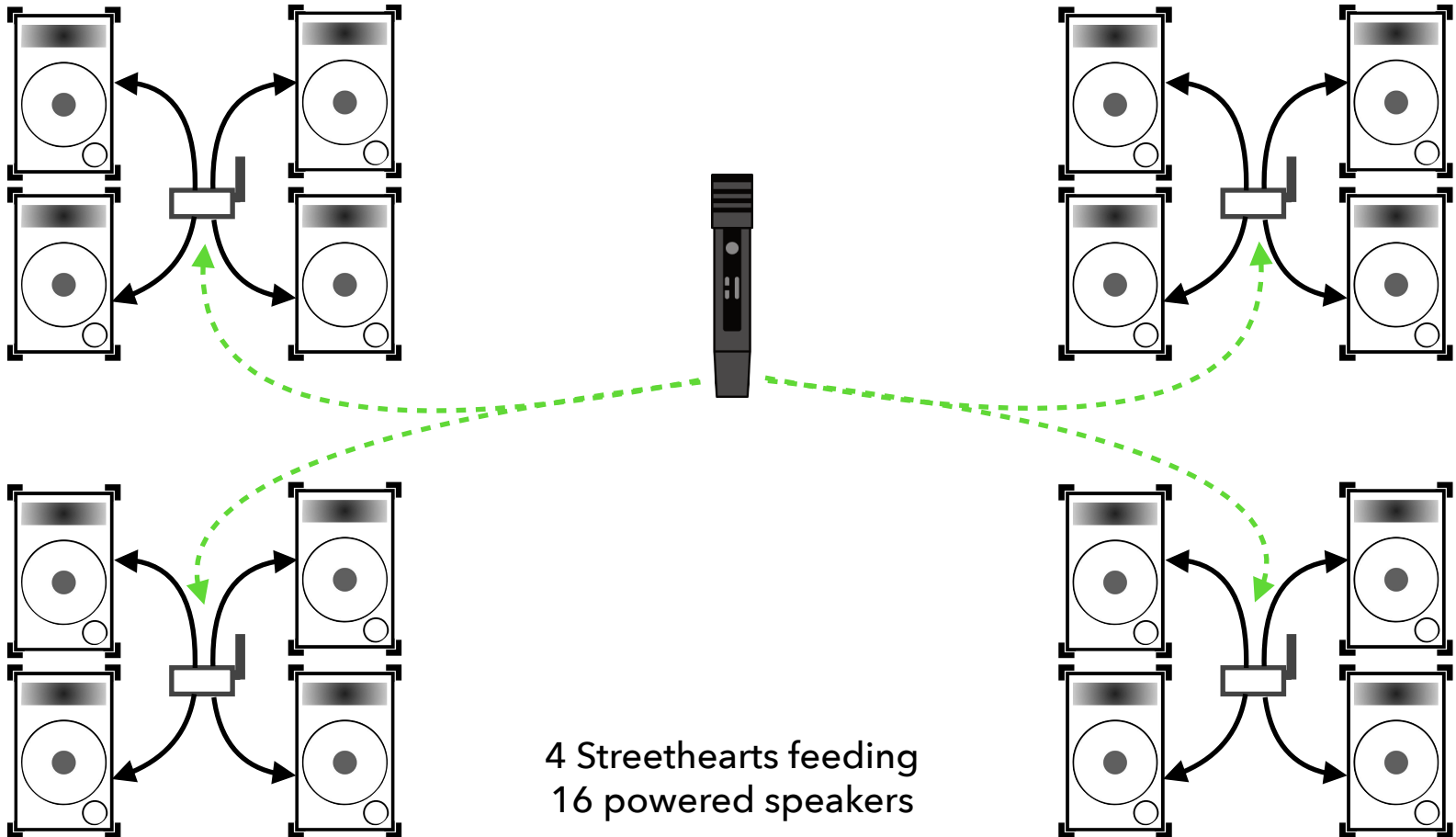
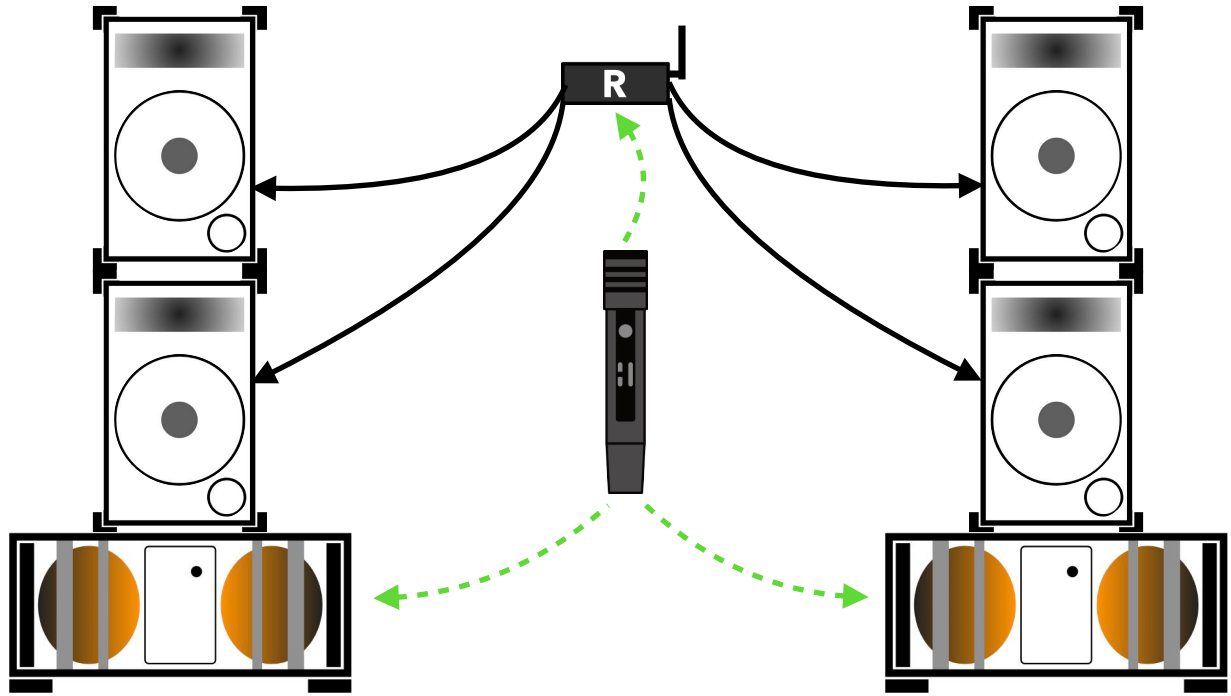

4 Streethearts feeding 16 powered speakers

STUDIO



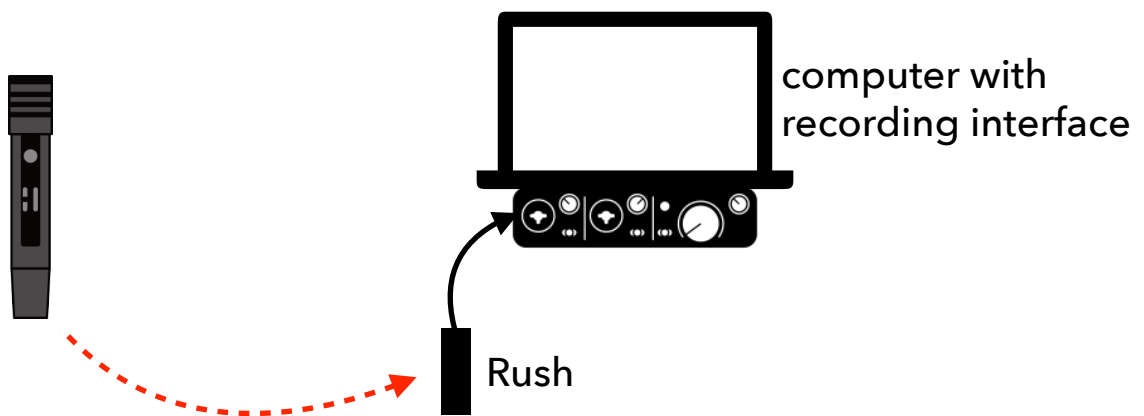
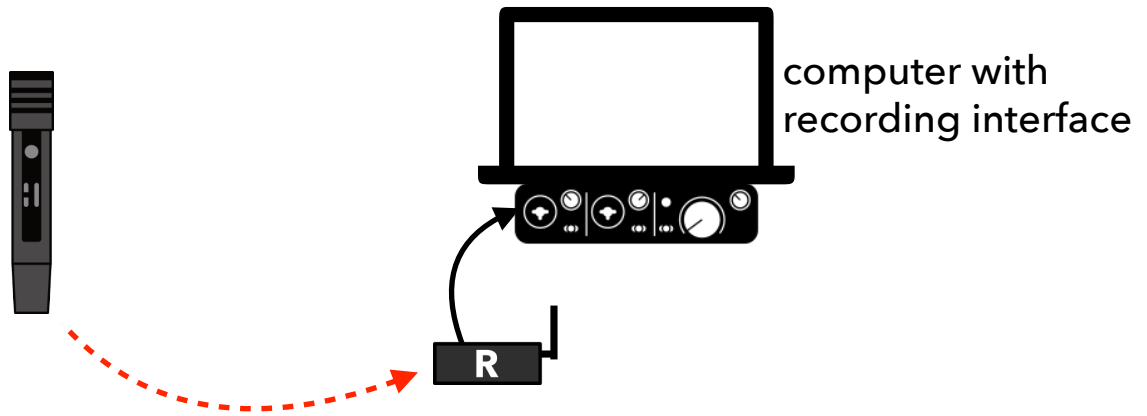

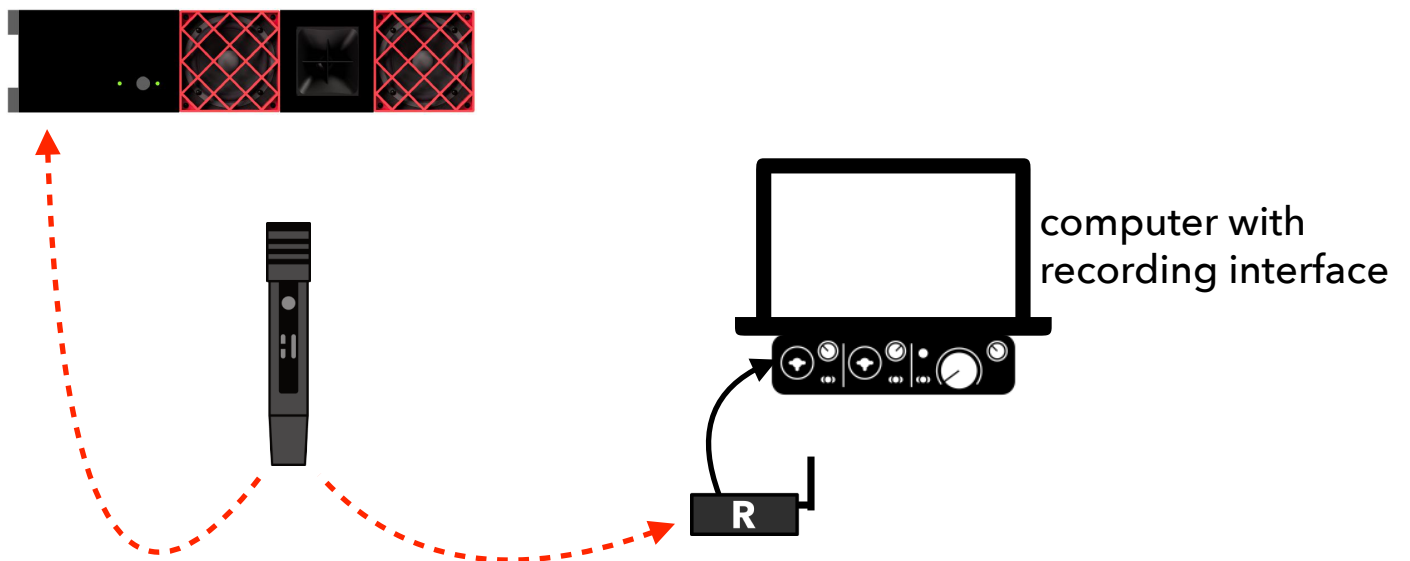
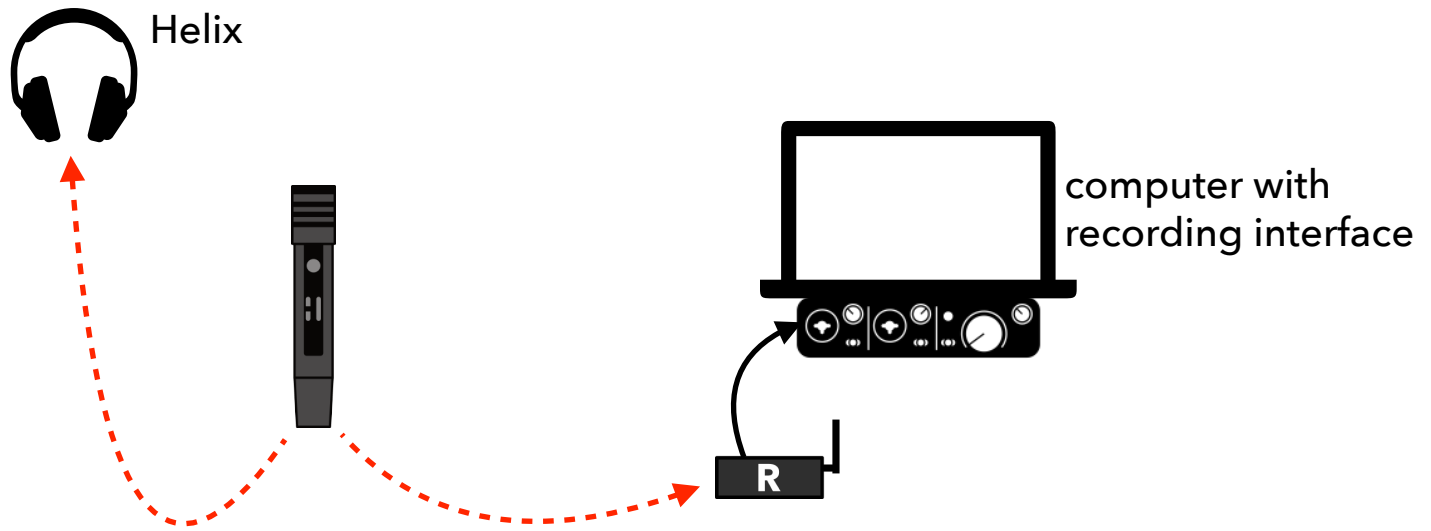

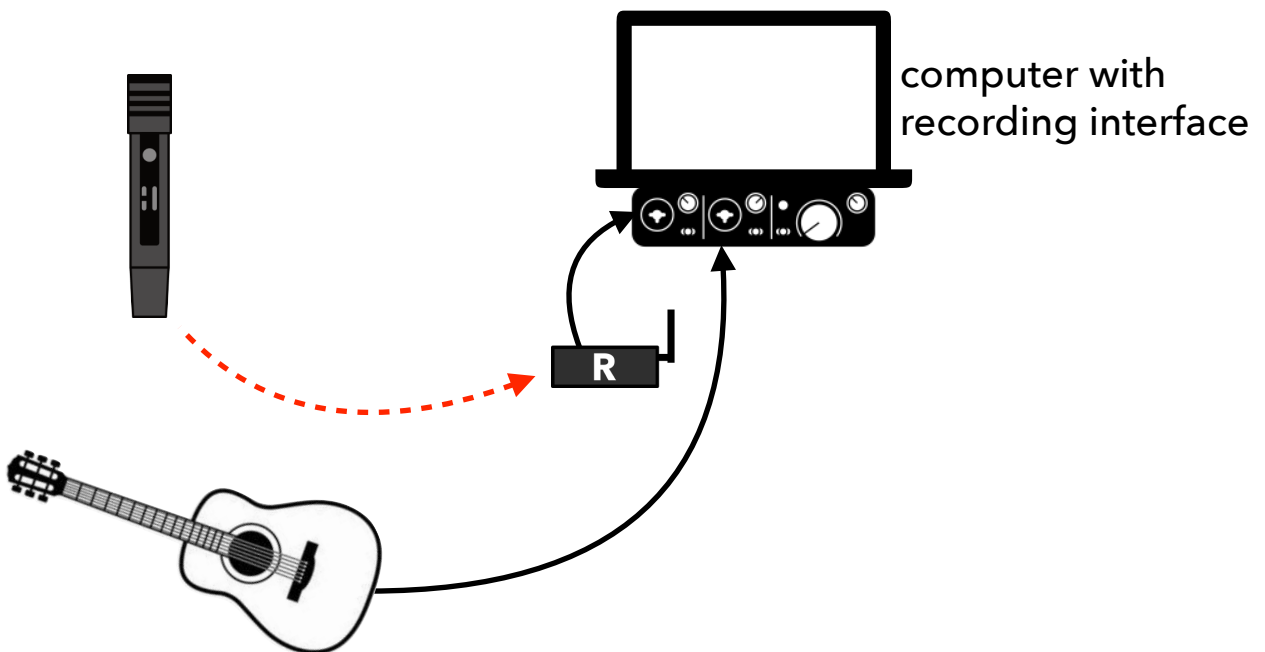
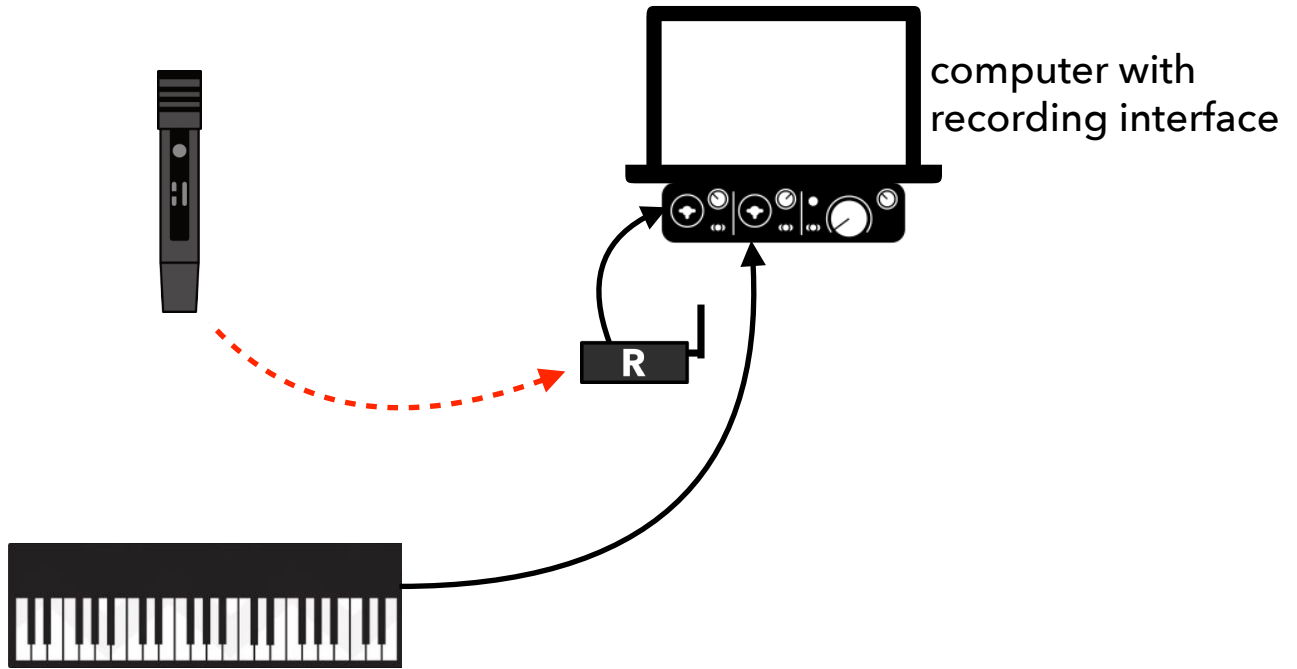

33

Take advantage of Streethearts Headphone Switch

wired headphones

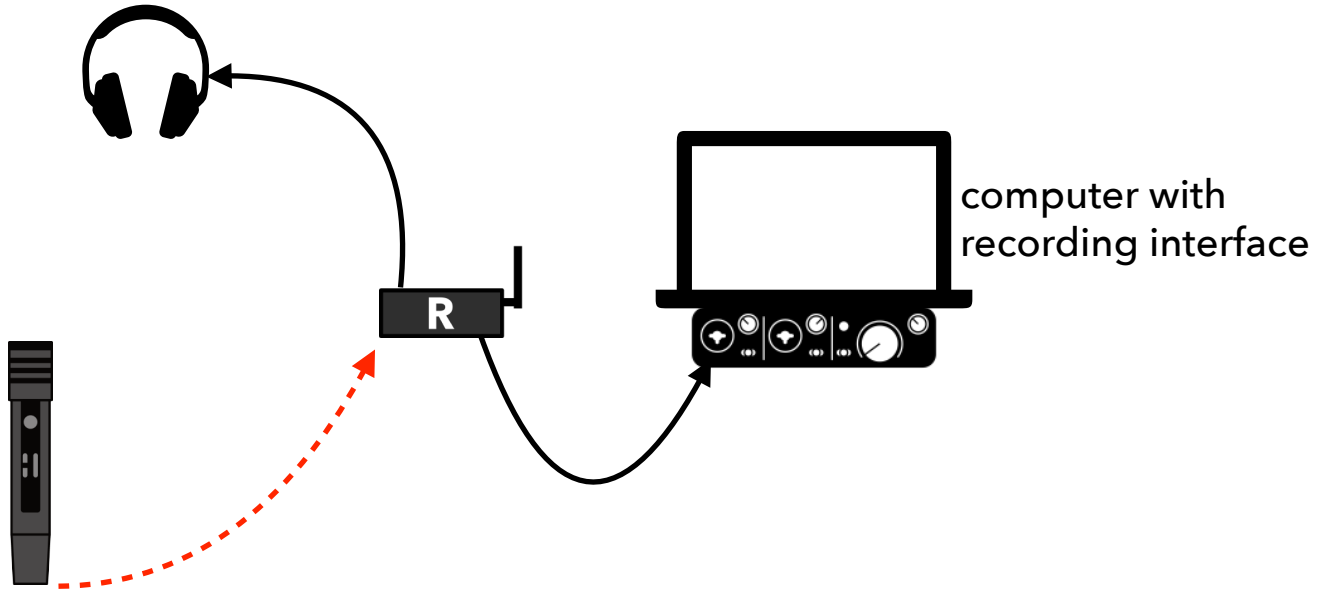

34

Add a pair of cans for your engineer

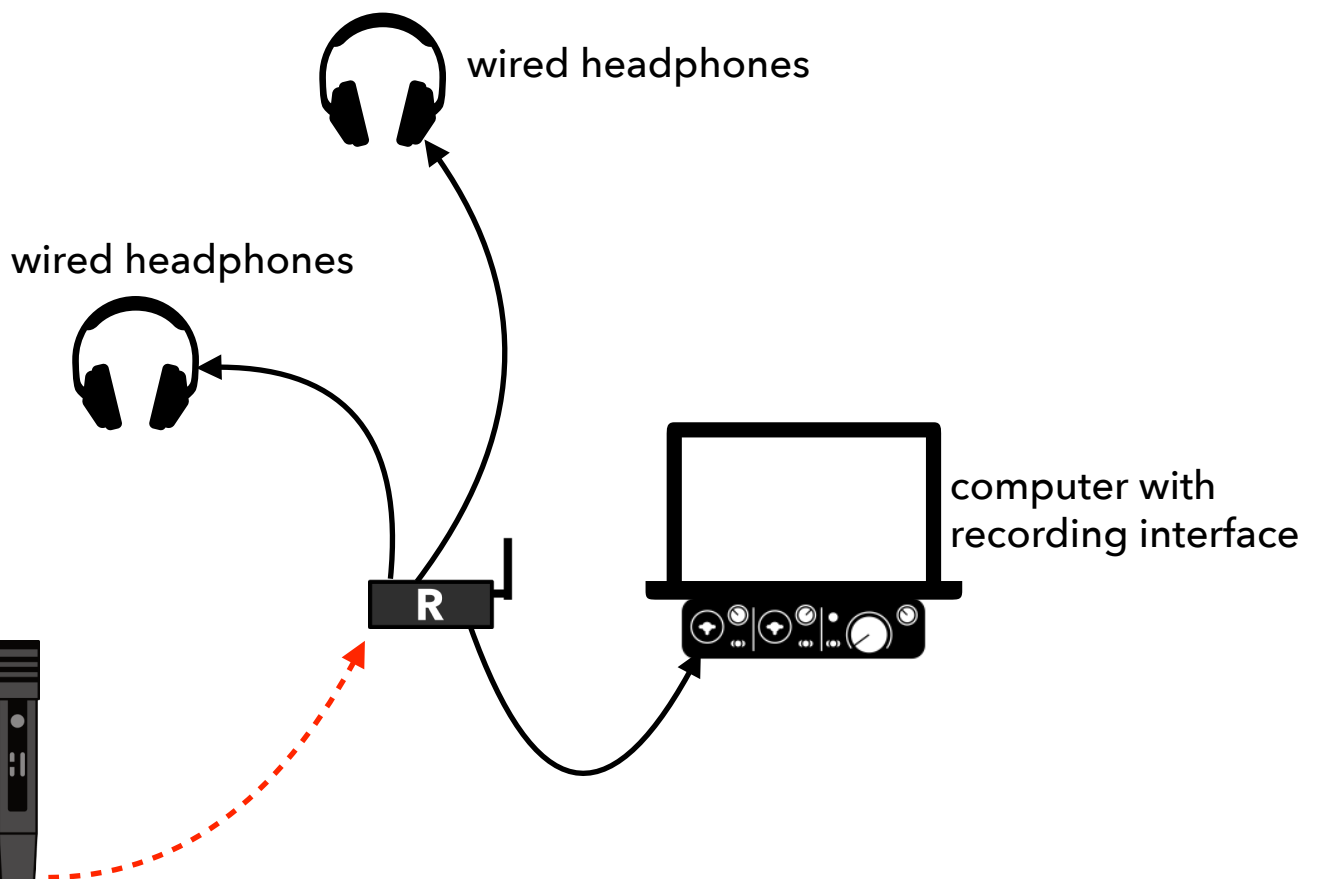

PRO DJ



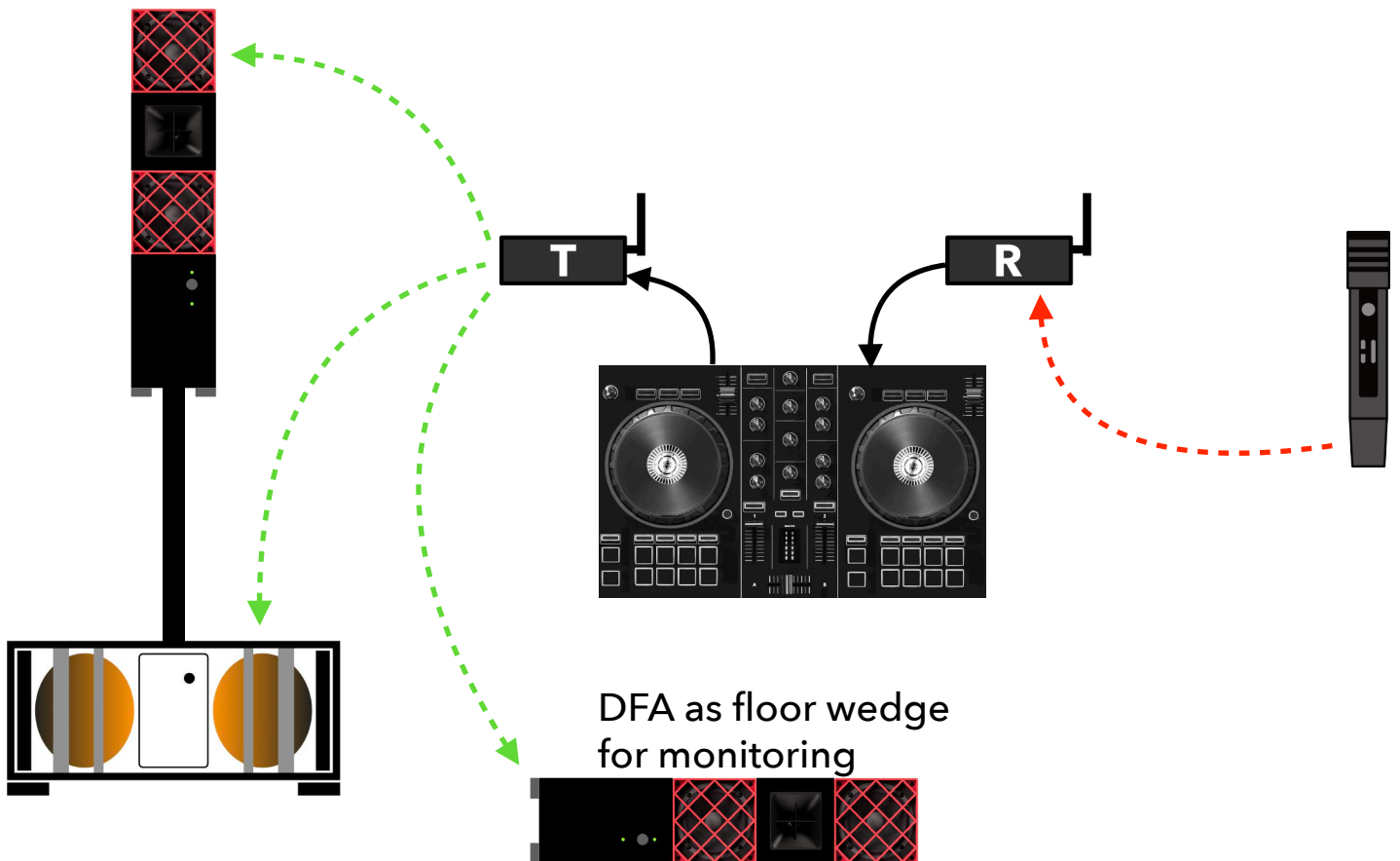
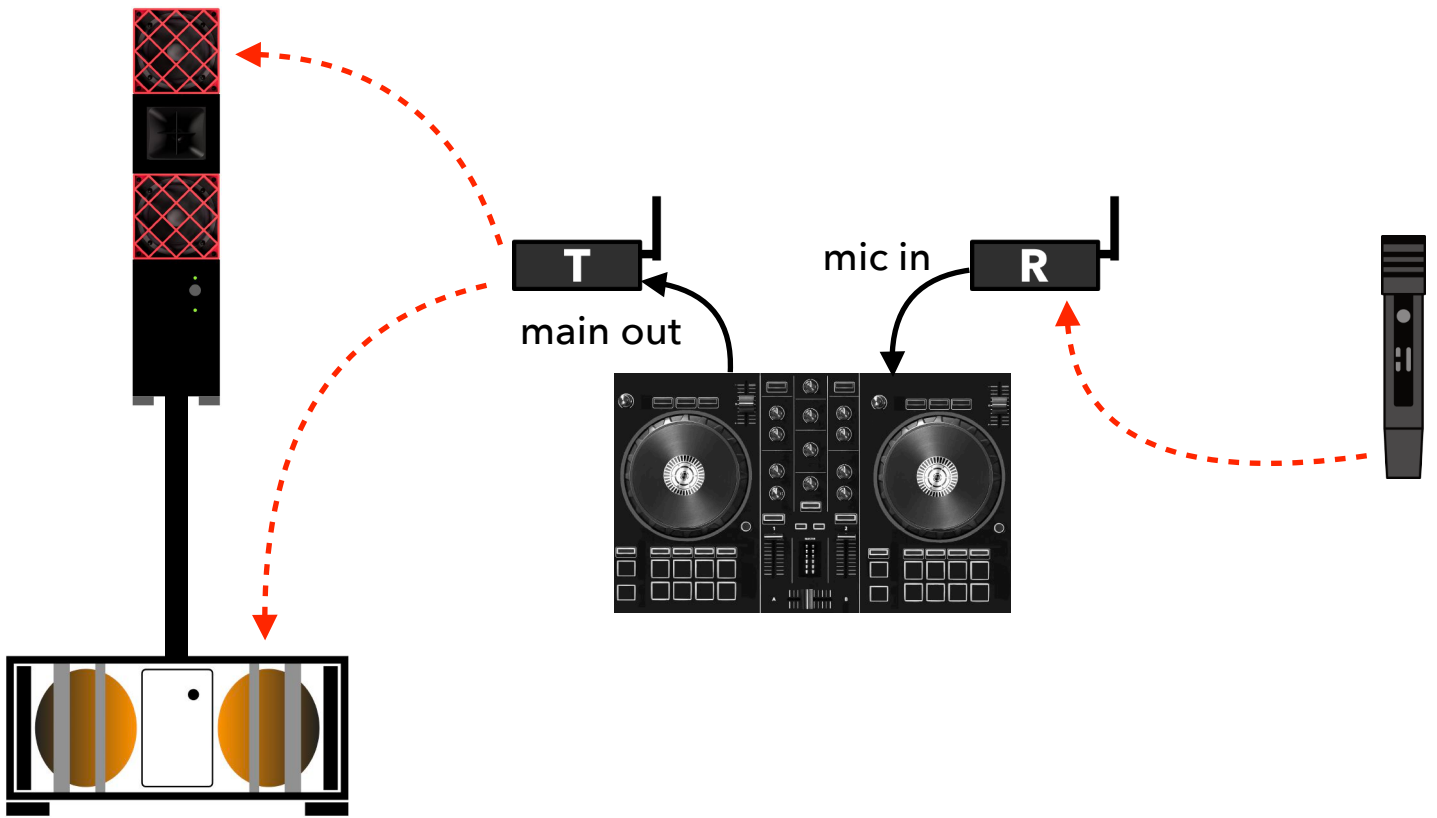

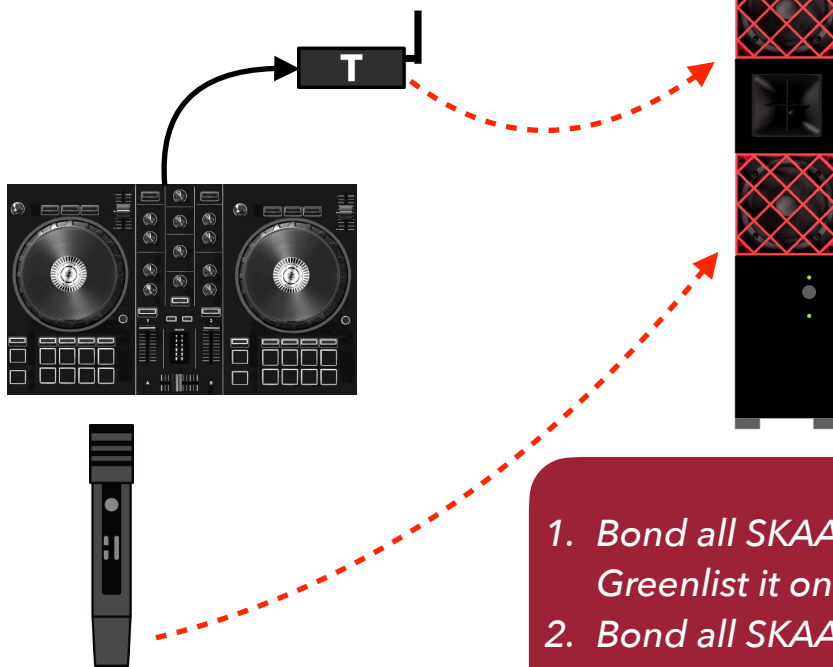
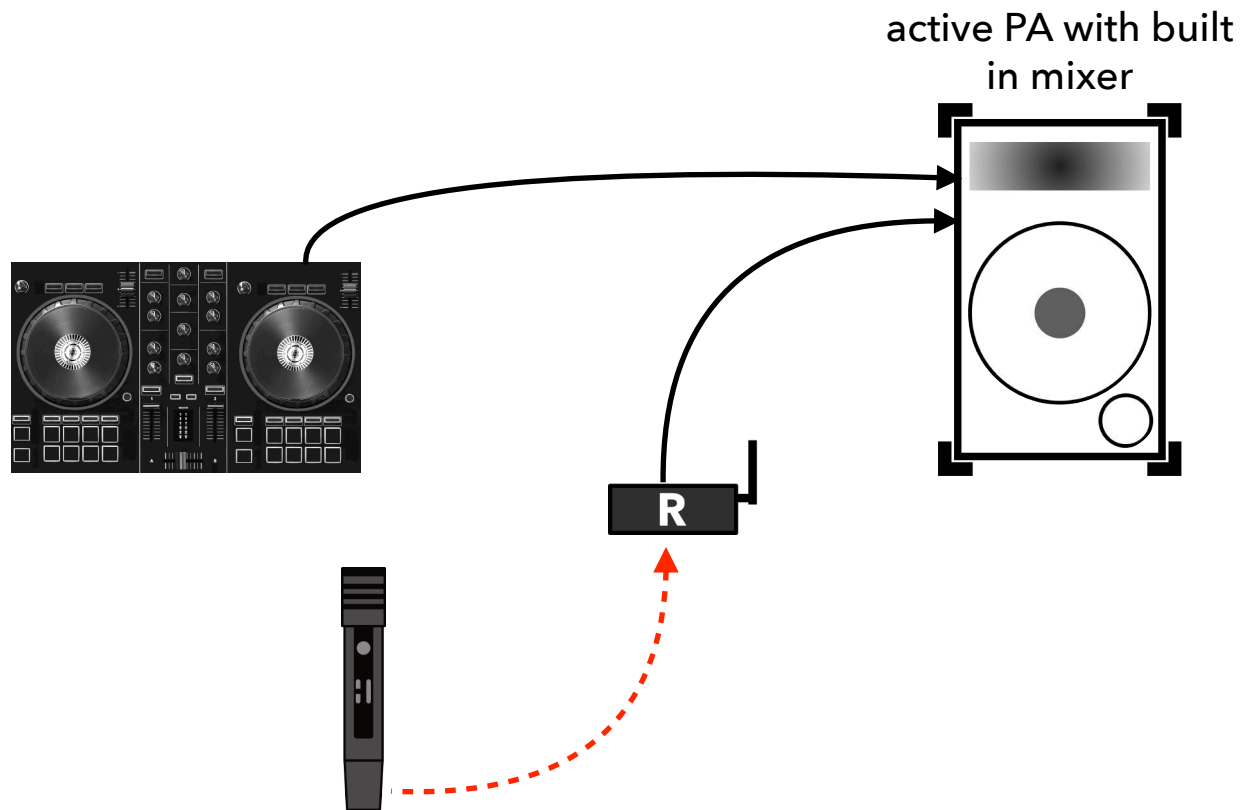

1. Bond all SKAA Receivers to Valerie Mk2 and Greenlist it on the Receivers
2. Bond all SKAA Receivers to Dani and Greenlist it on the Receivers
3. Switch all Receivers to Red Mode
4. When you need to make an announcement, quickly power off Dani
5. When finished, power Valerie Mk2 off and Dani on!

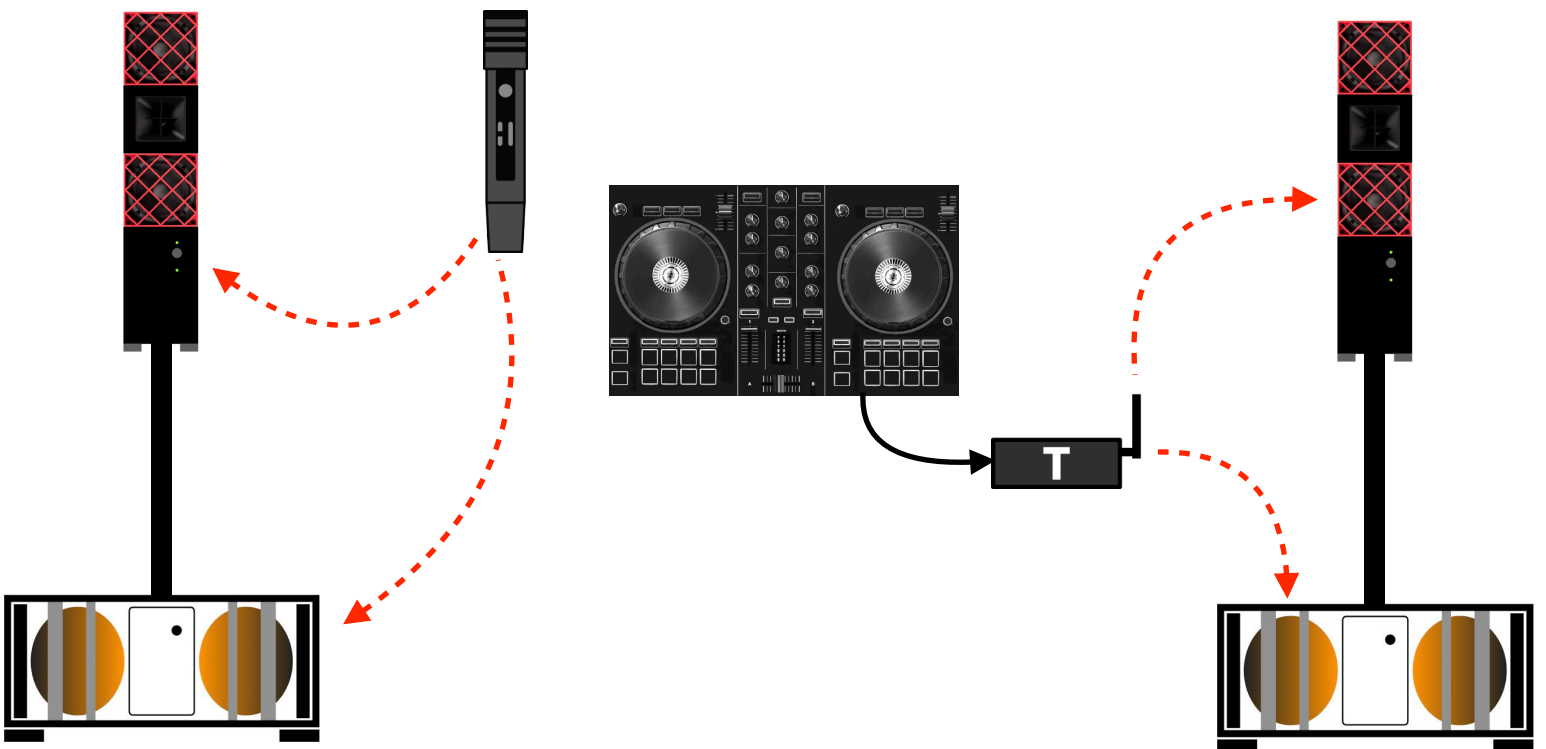
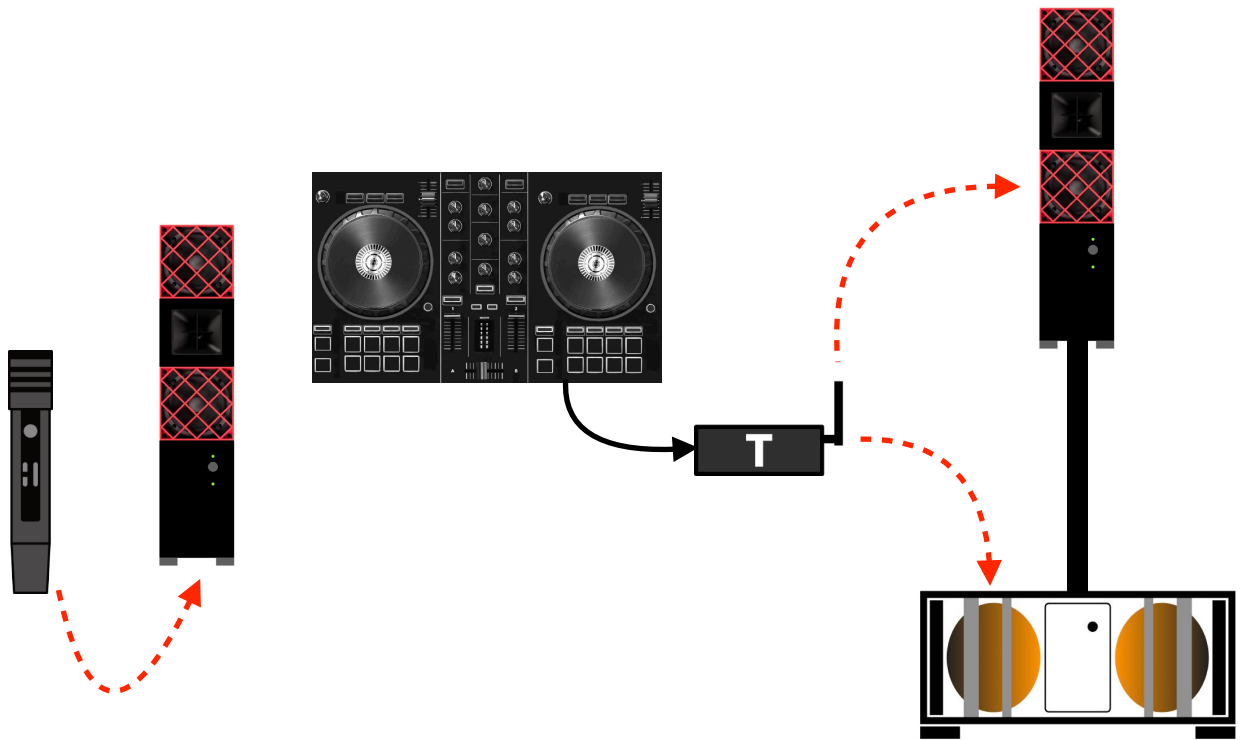

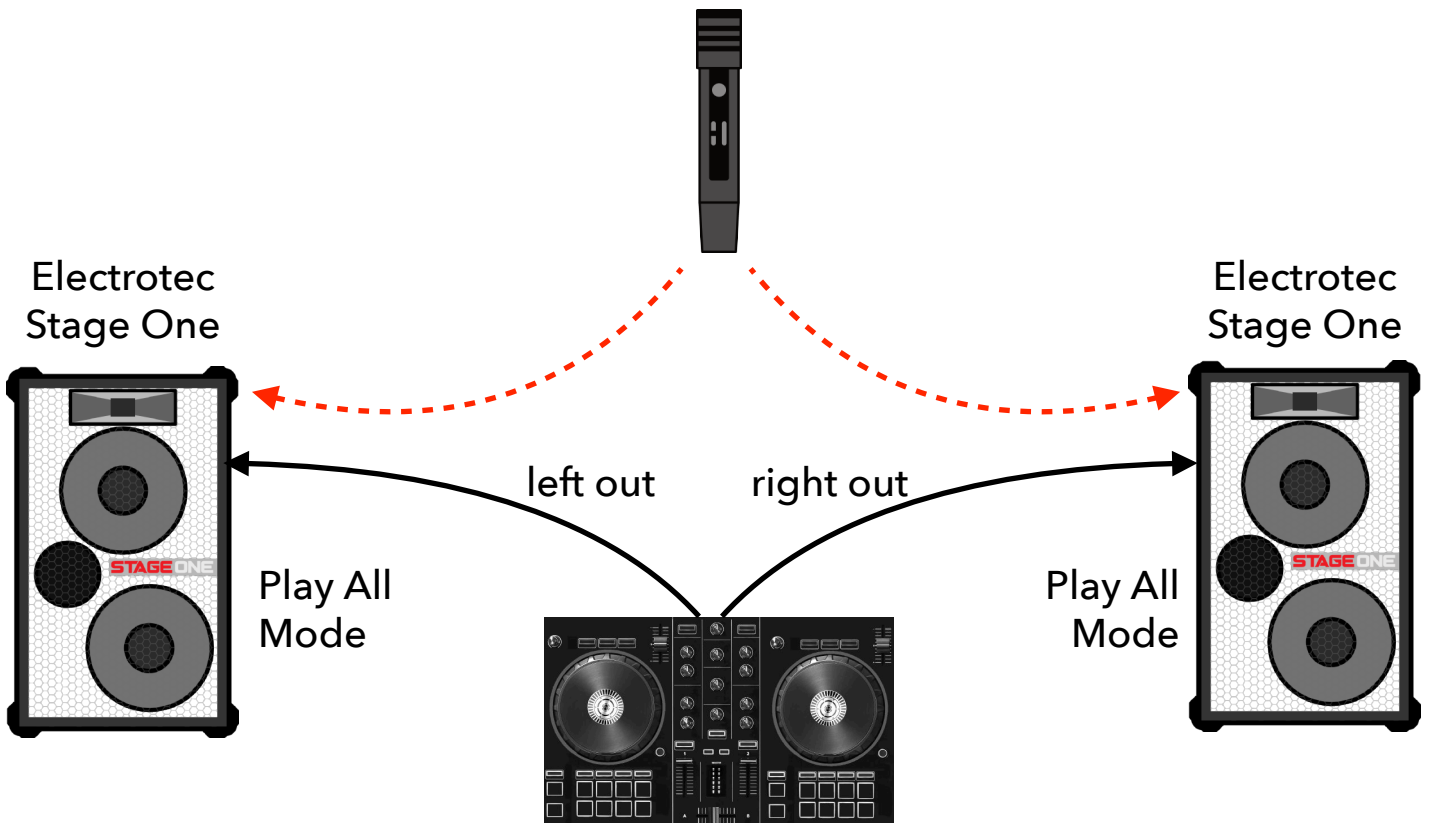
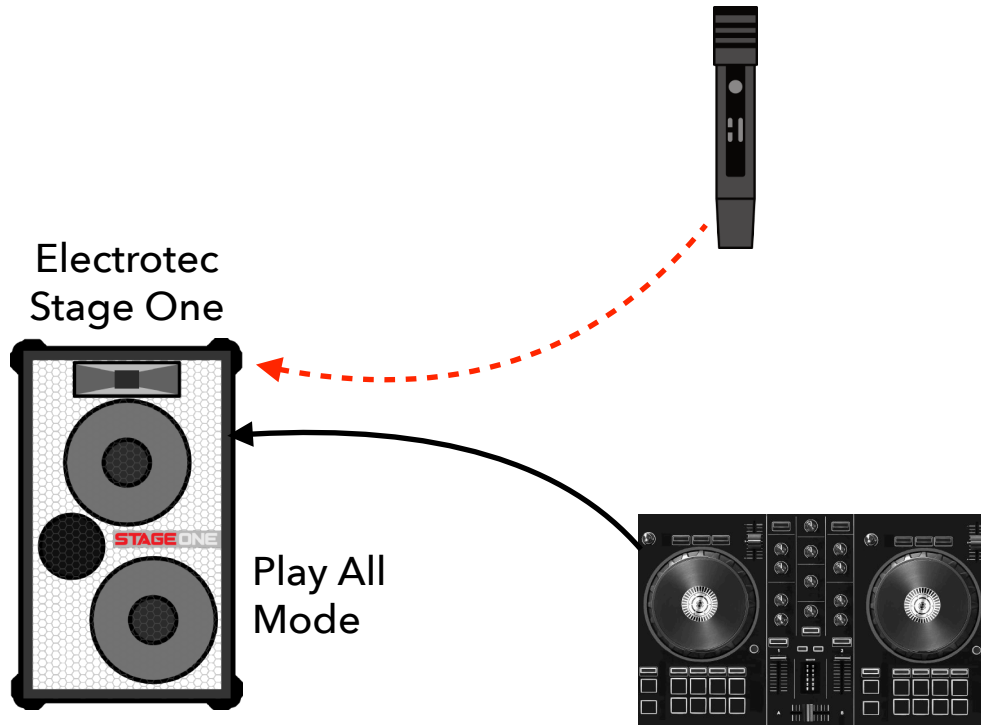

DECKLESS DJ RIGS



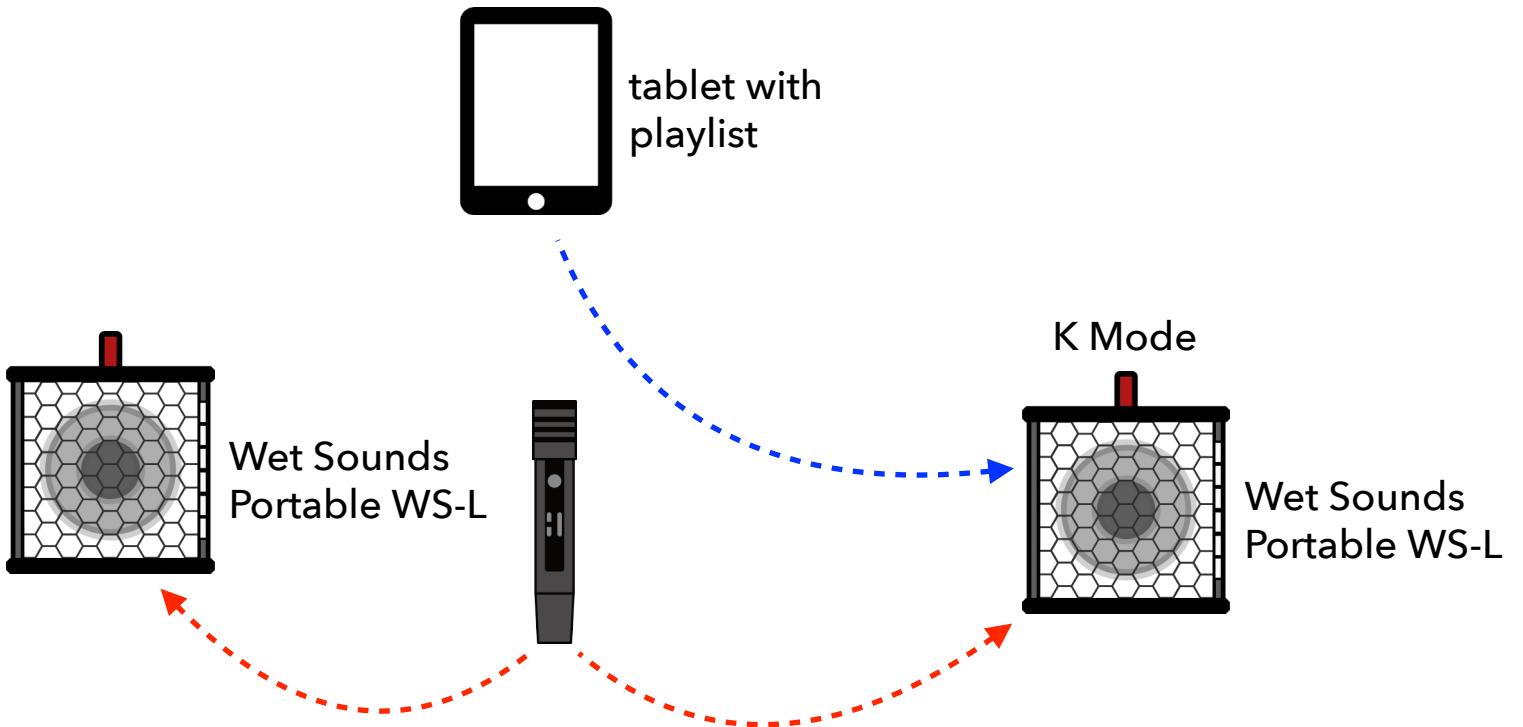
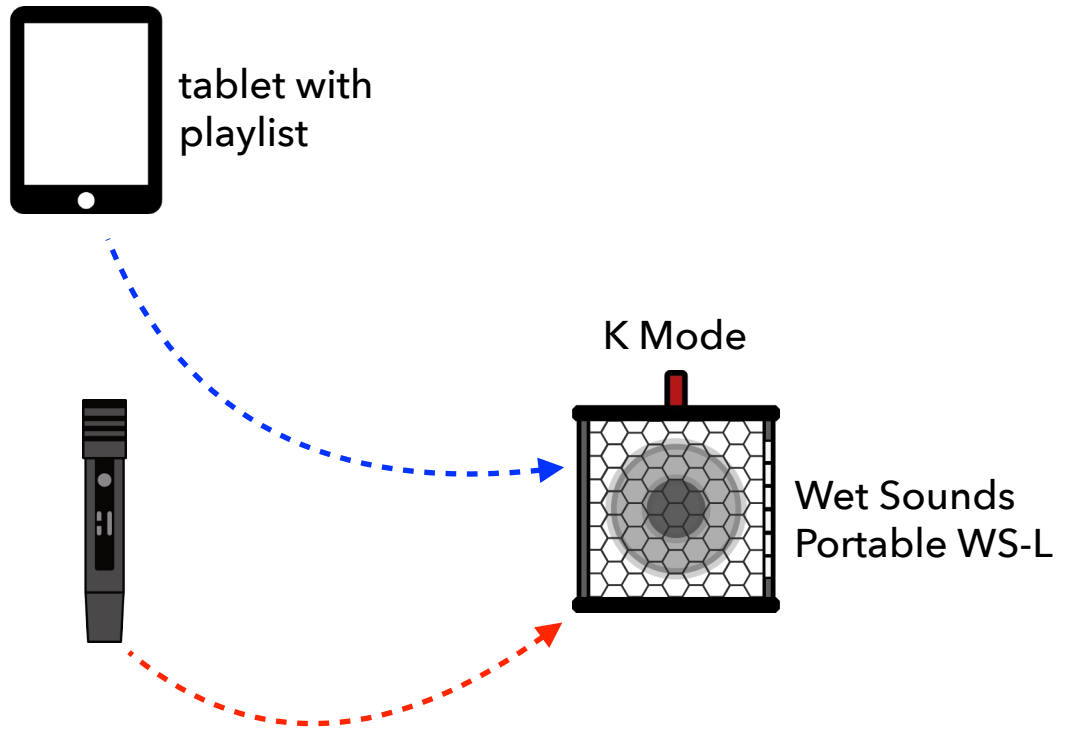

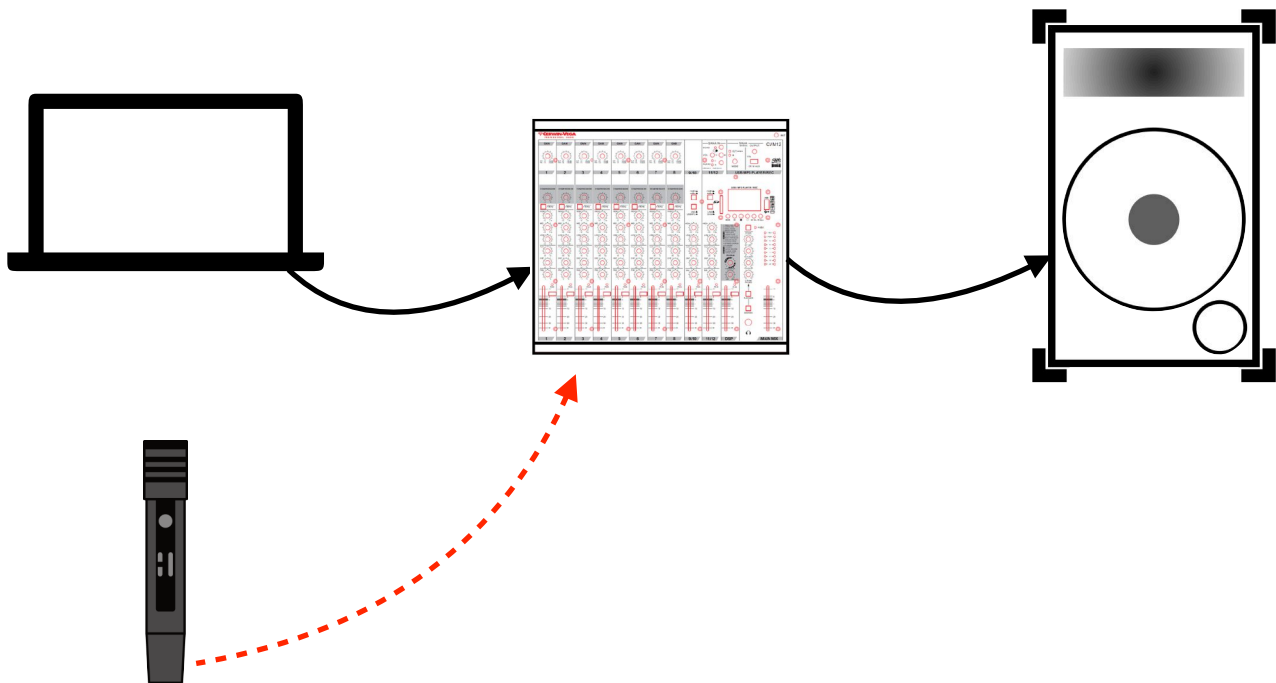
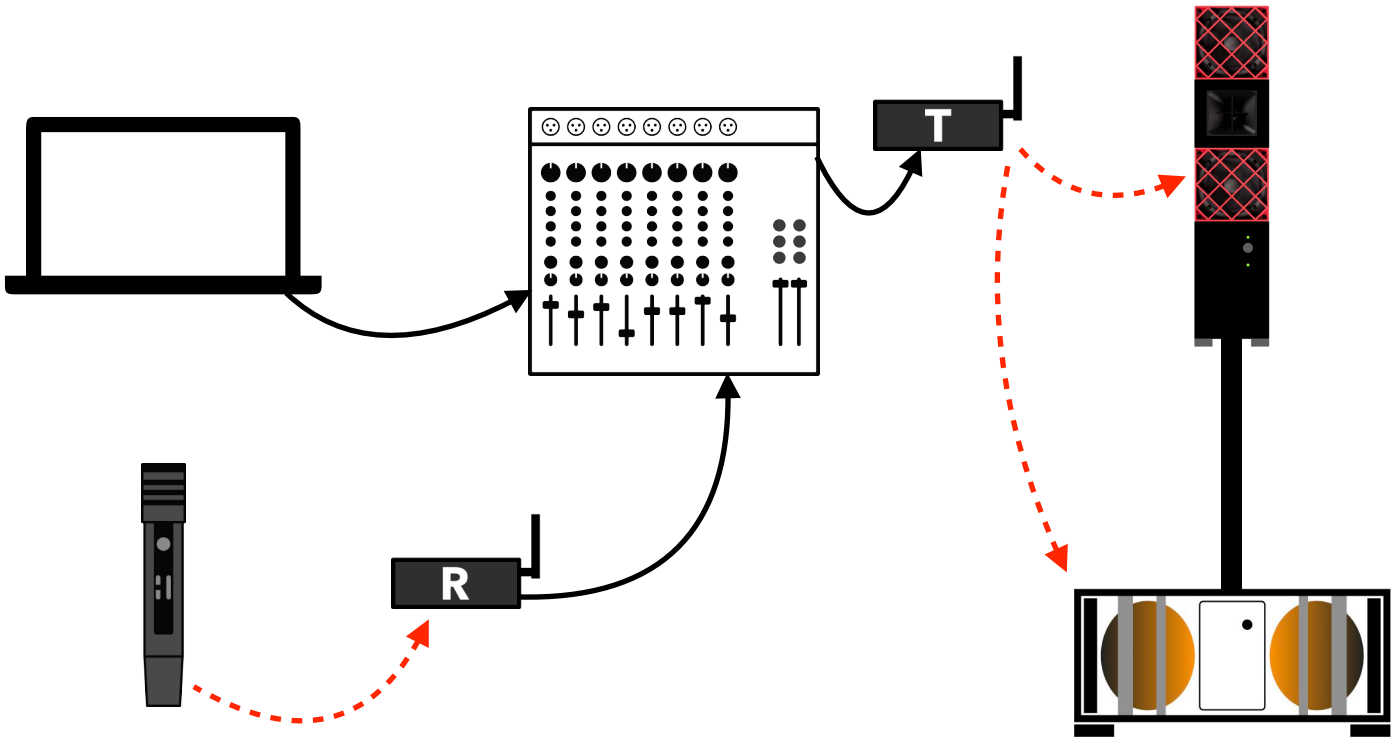

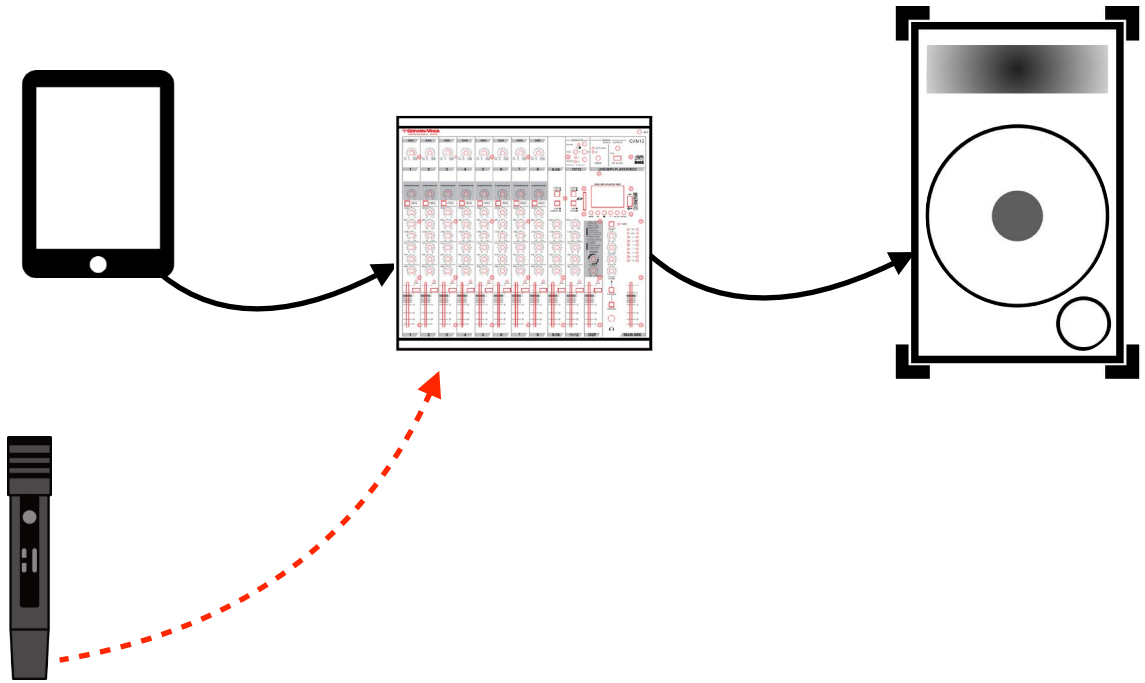

Take advantage of your PA speakers built-in mixer

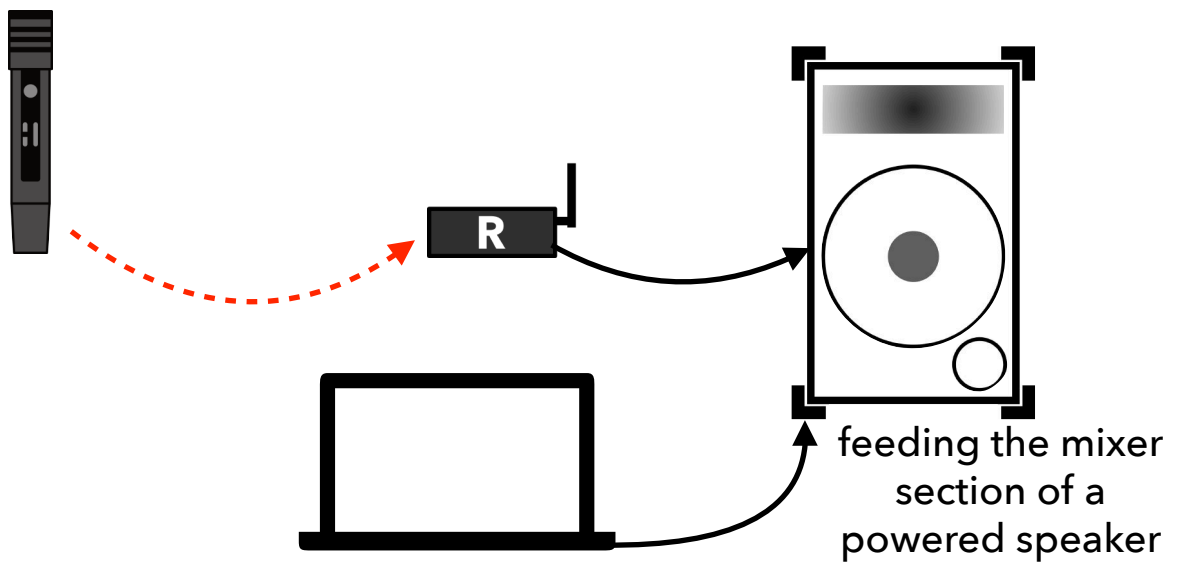

51

Pimp the old venue setup...

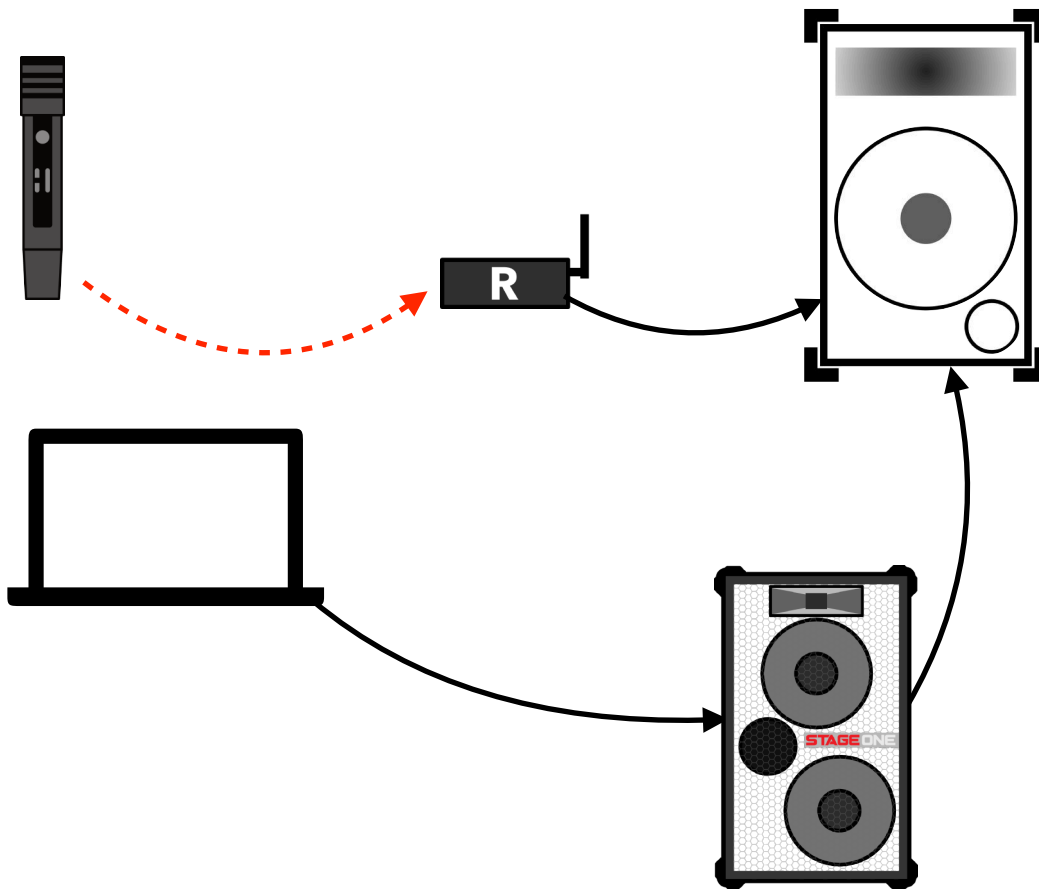

52

...and add coverage for the kids table

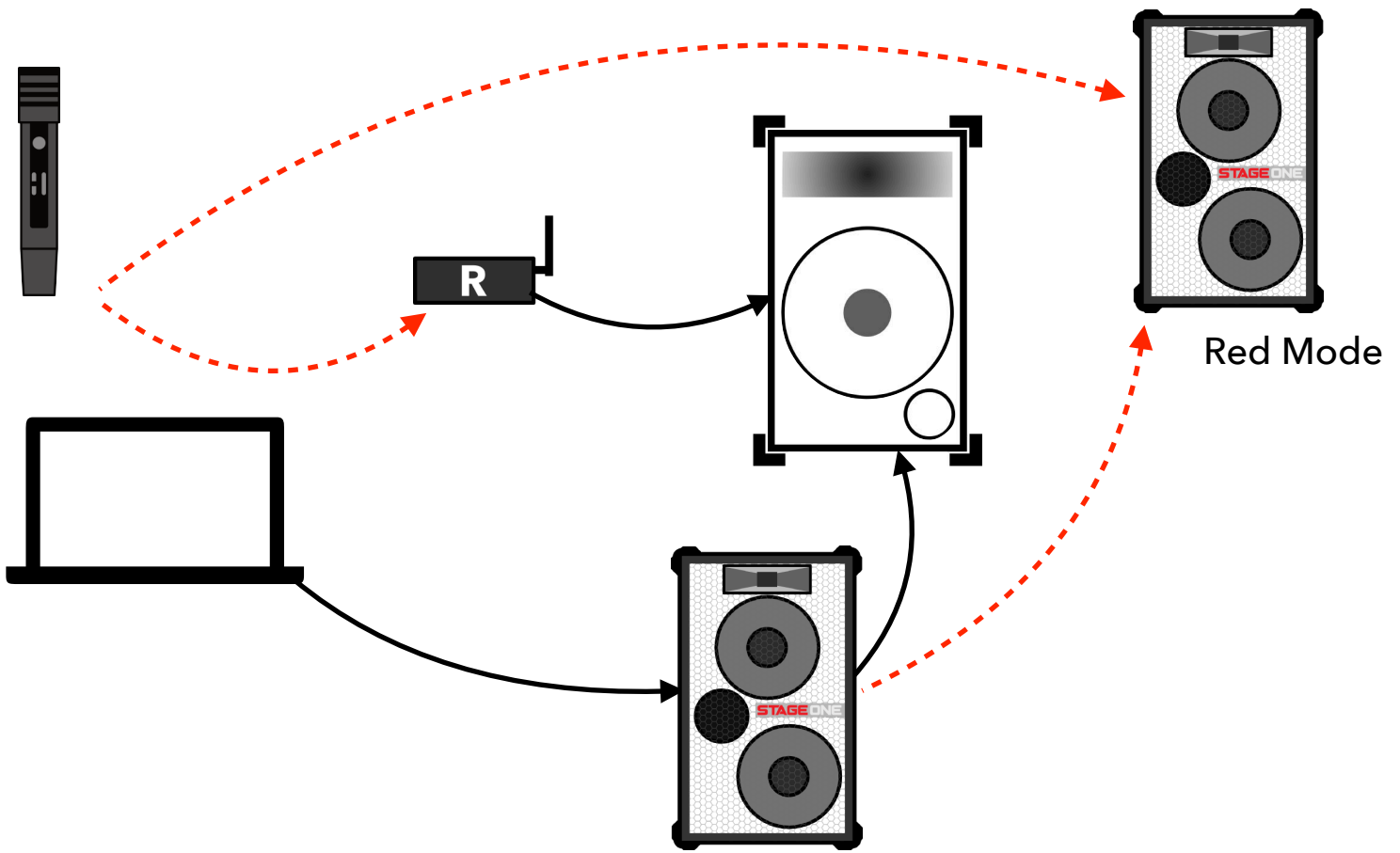

HOME



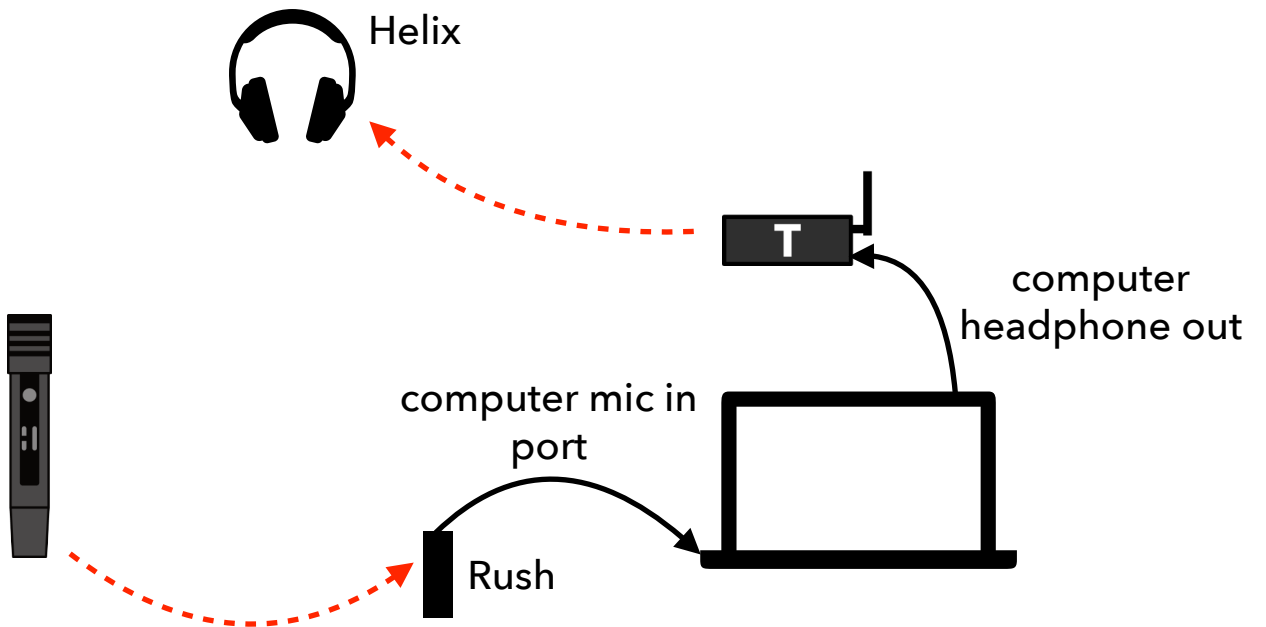
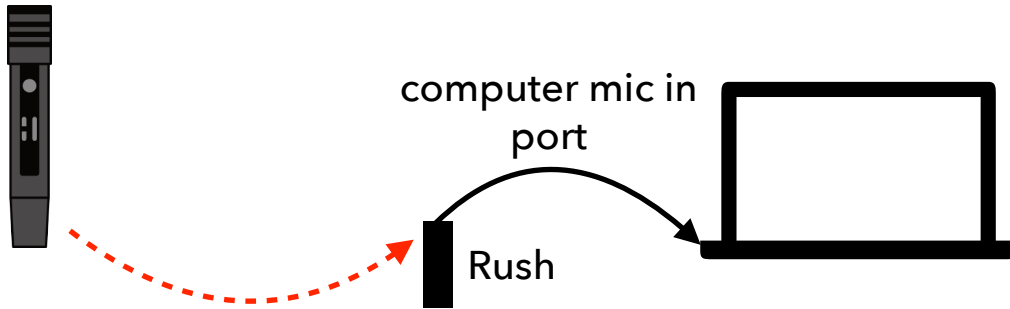

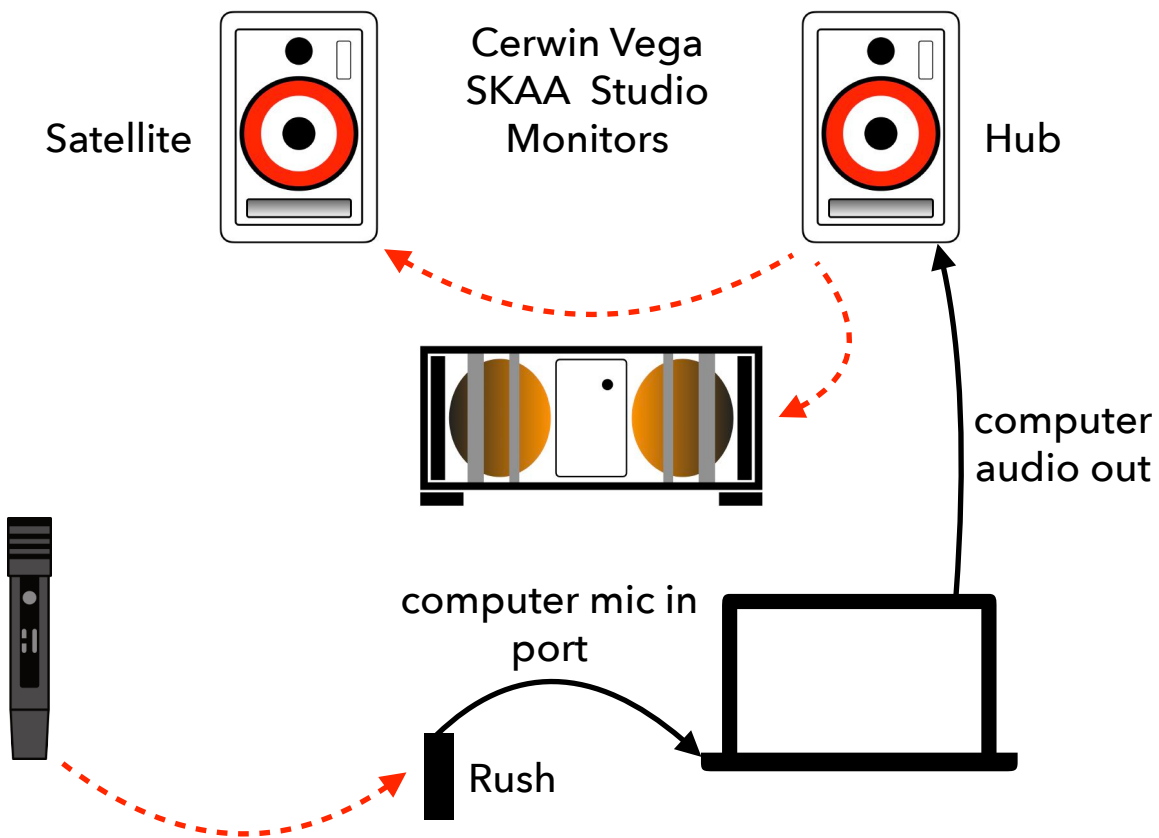
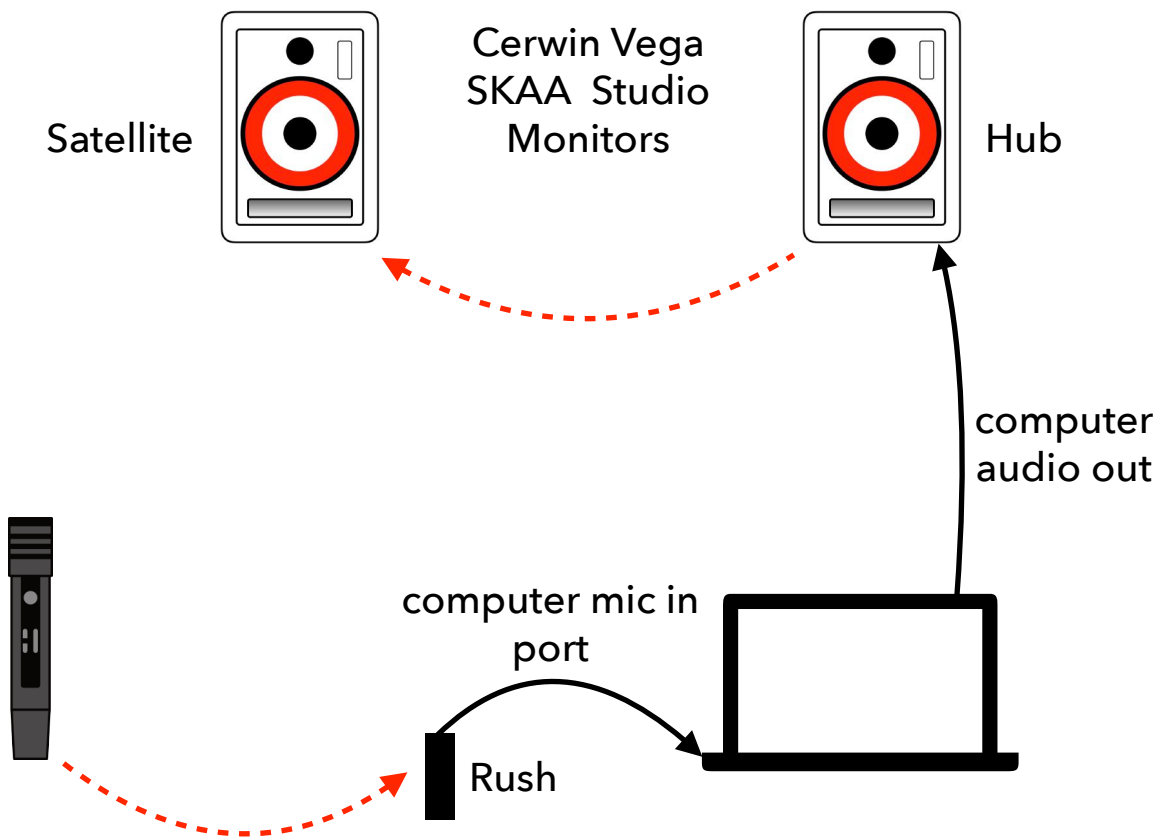

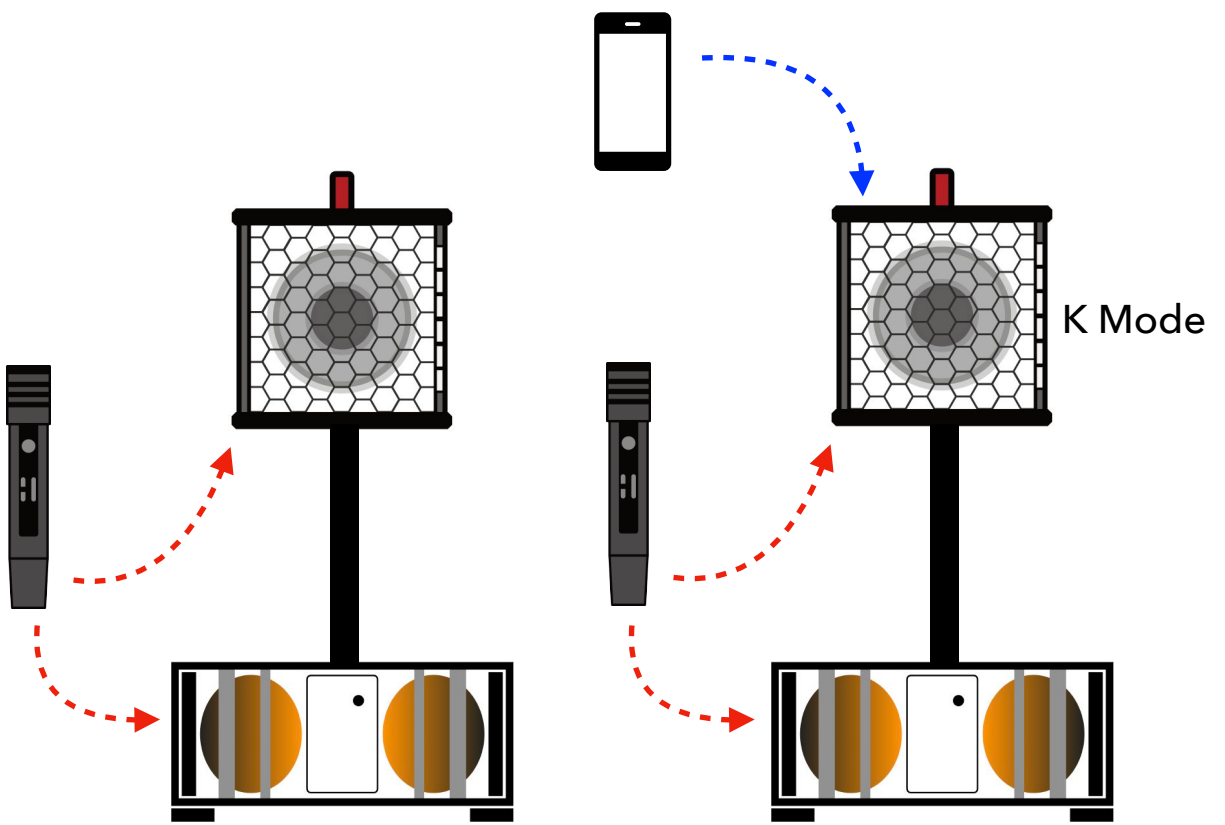
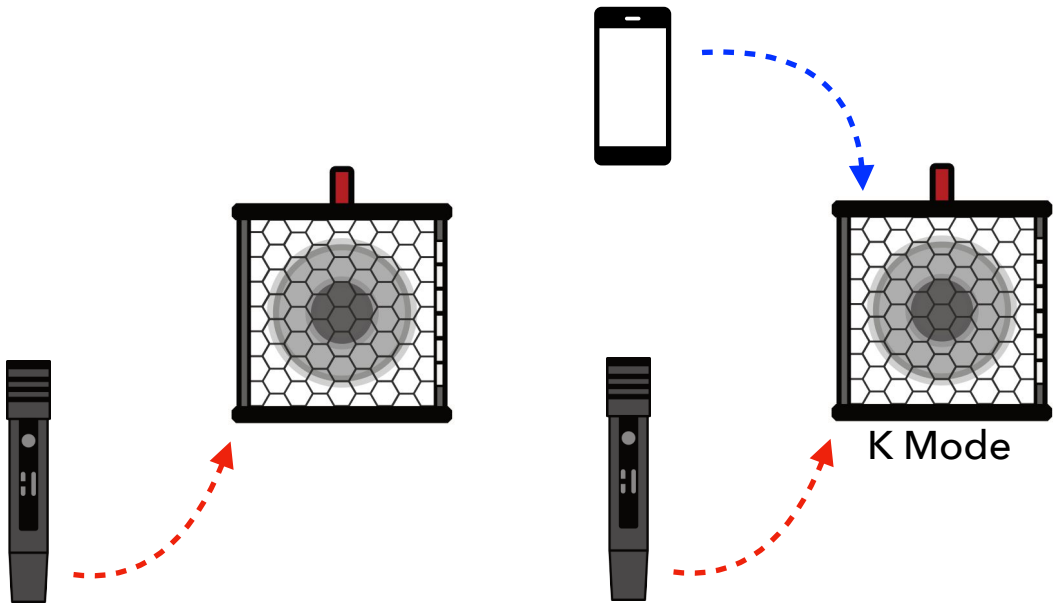

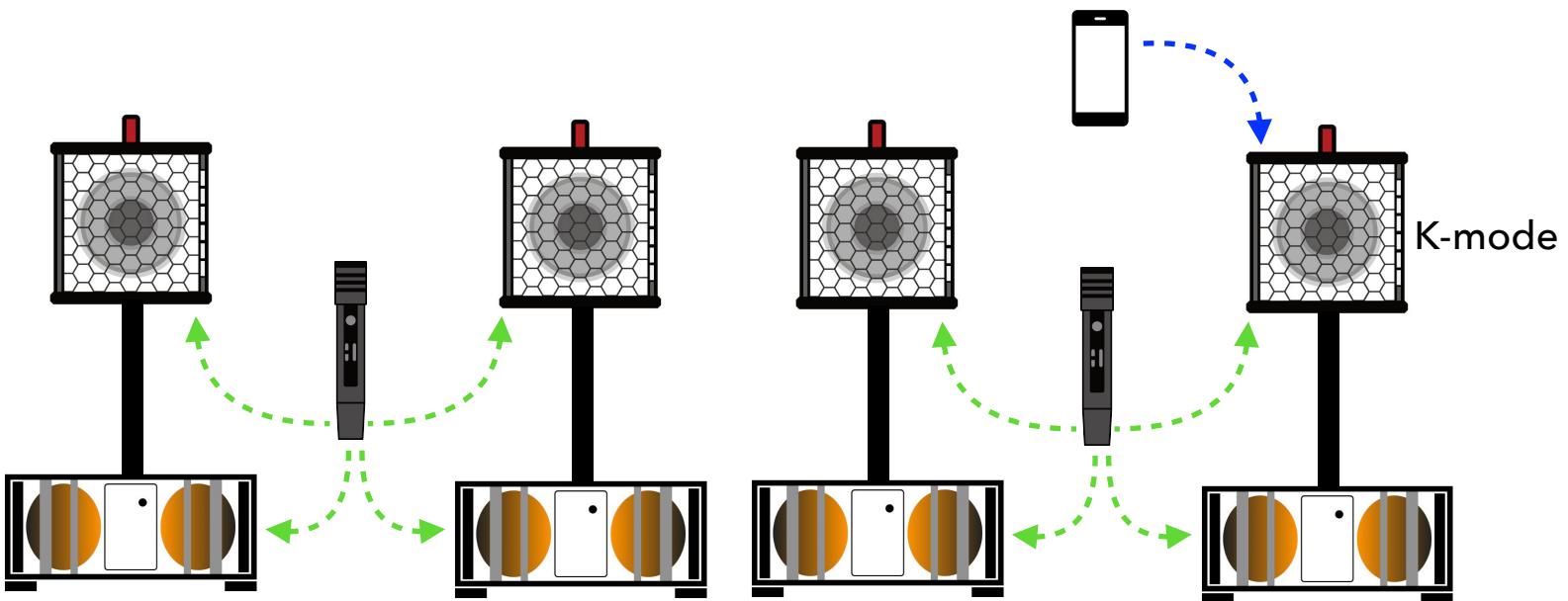
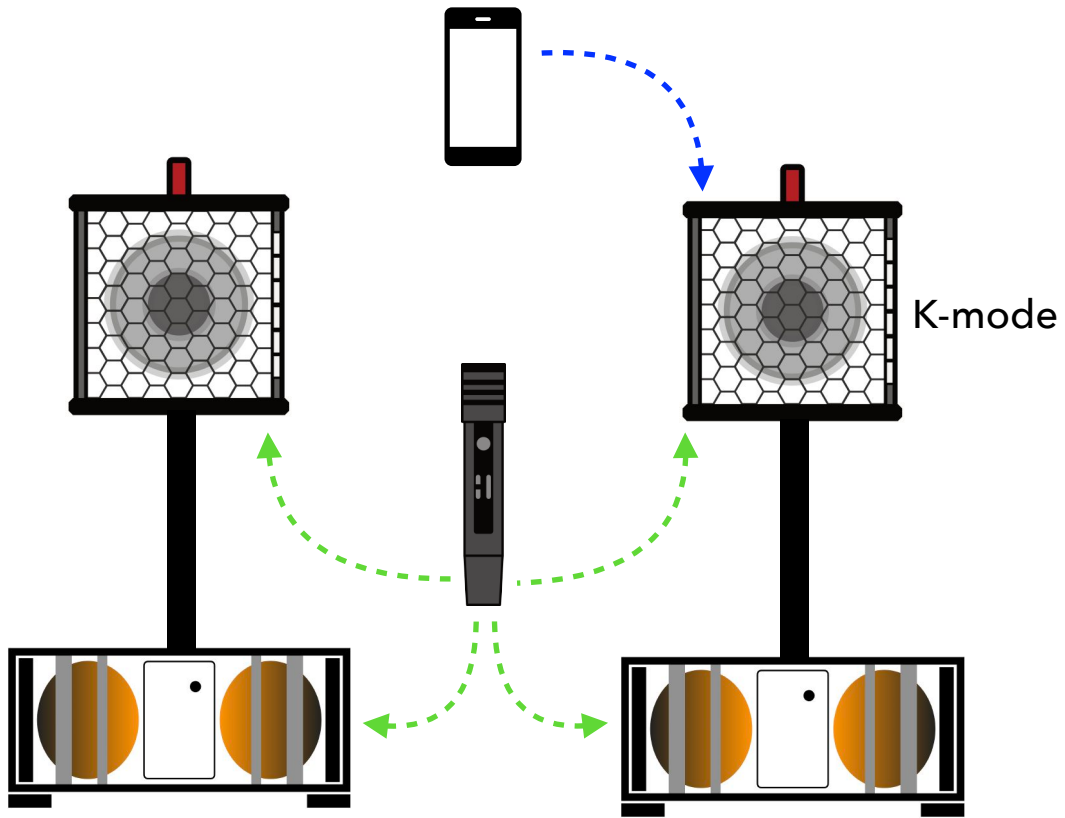

CREATOR



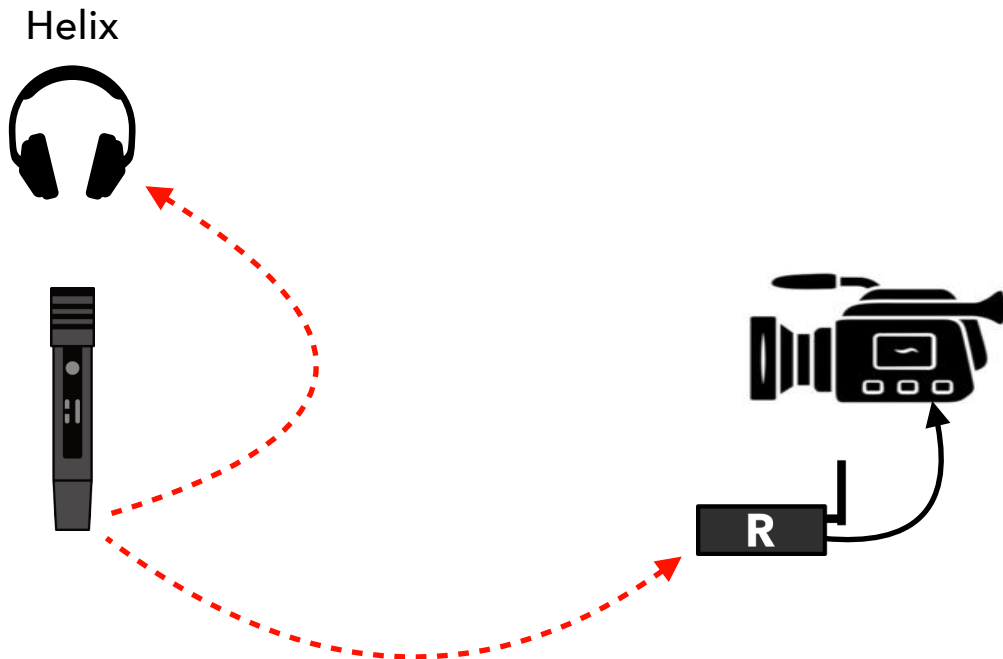
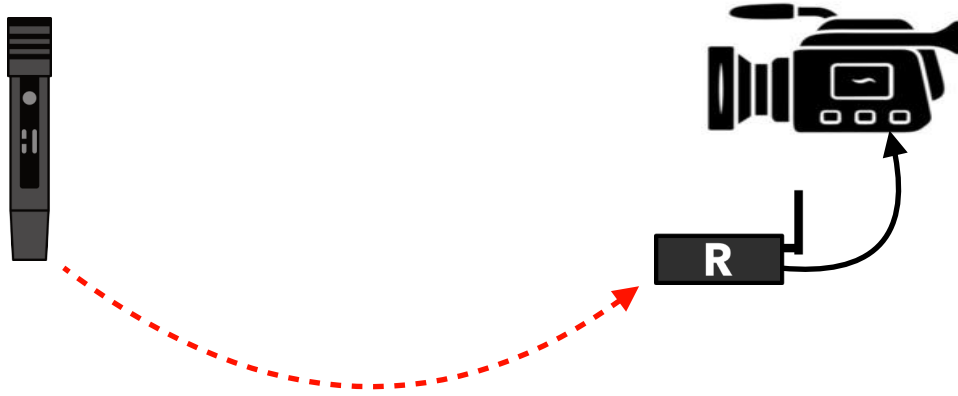

63

Well monitored with existing wired headphones

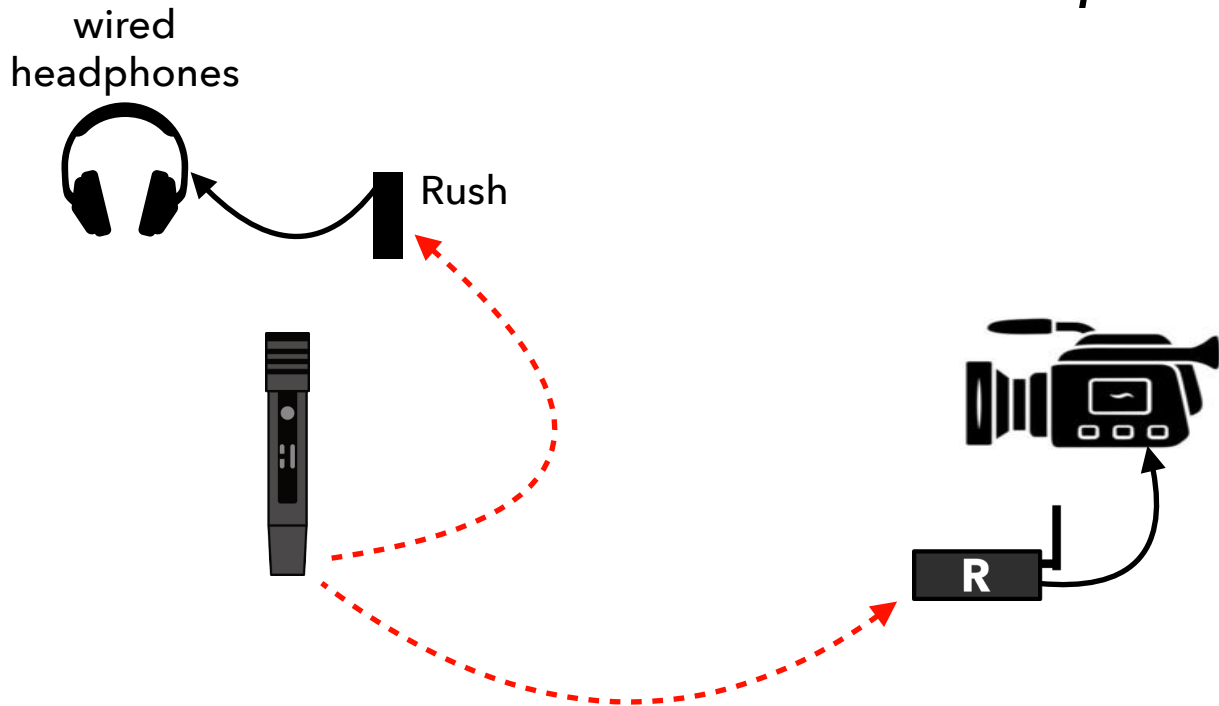

64

Crowd work + filming

Valerie Mk2 can send audio to multiple destinations, so we capture that audio on our camera at the same time we're capturing video – Streetheart is a perfect receiver for this since it's long-range, and has a built-in battery

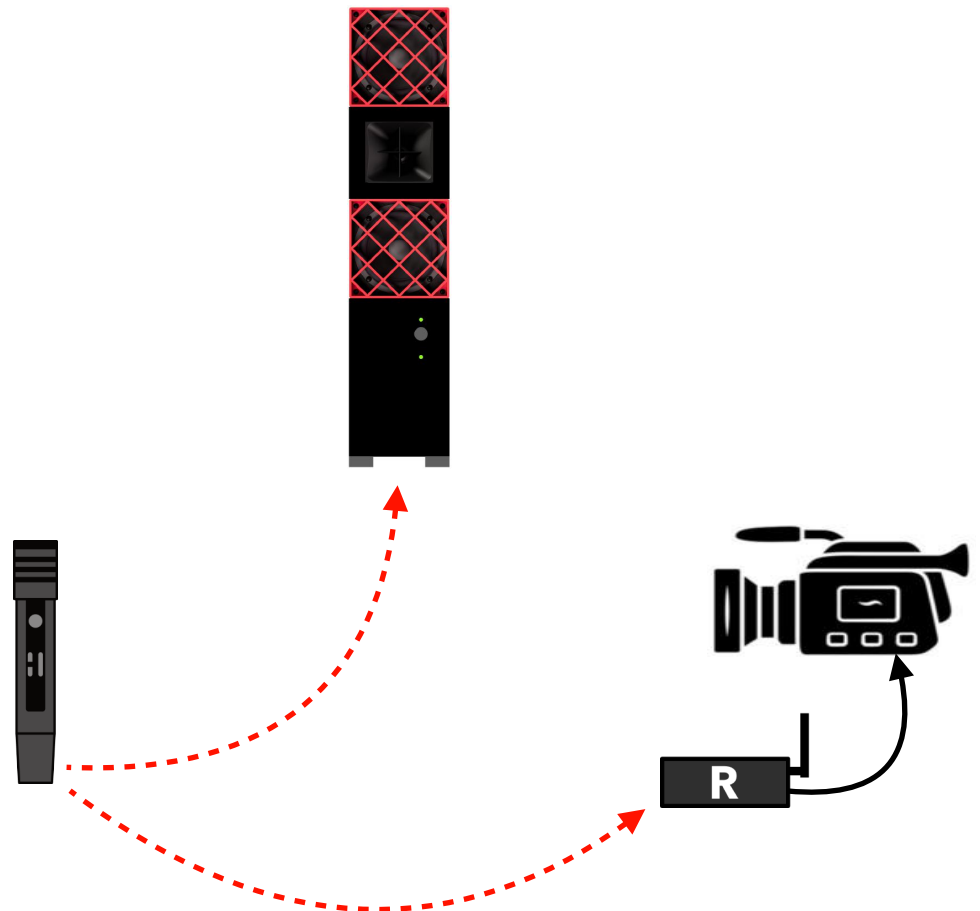

65

Incorporate an existing speaker into your content

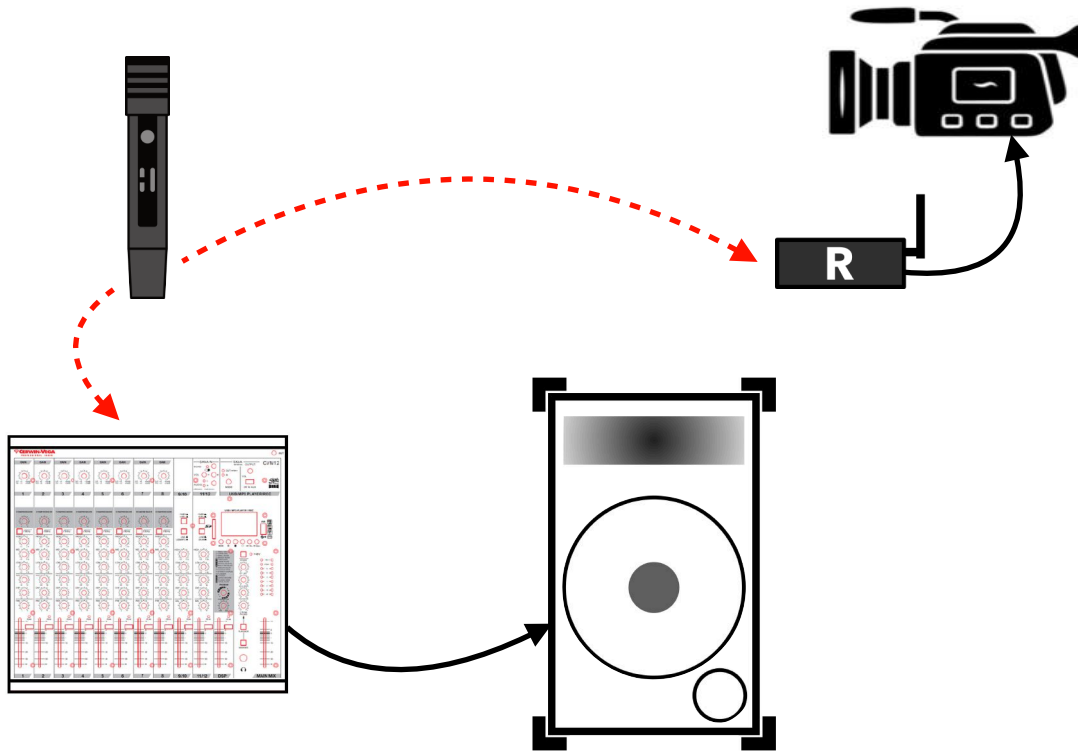

66

Guitar + vocals video

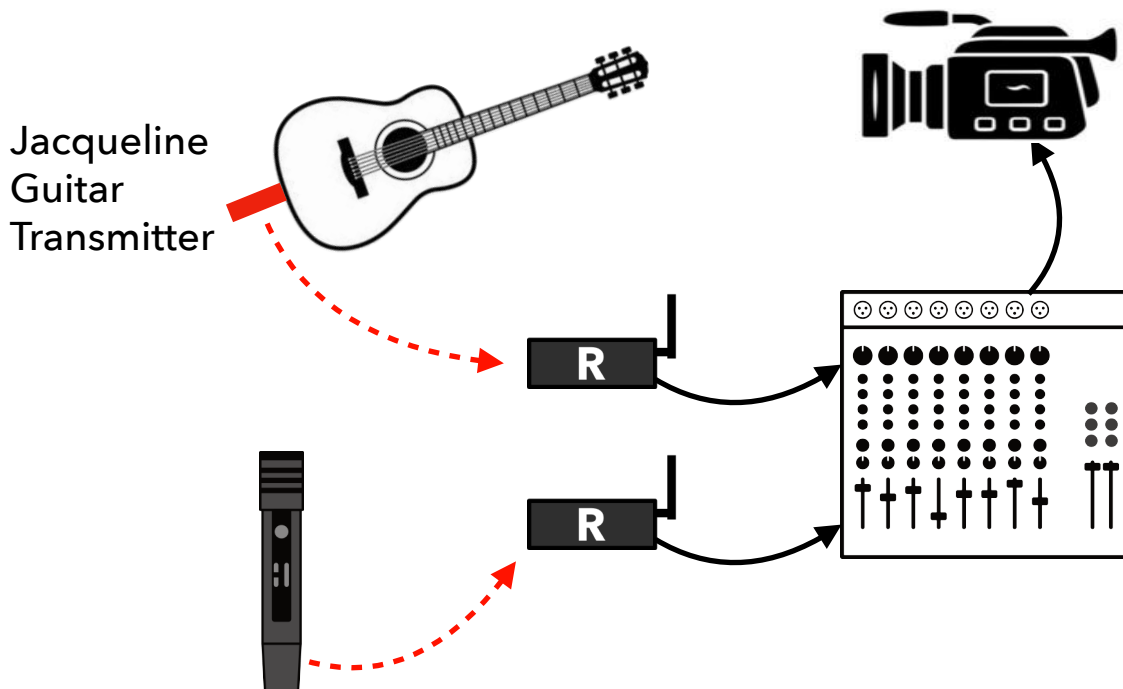

67

Wireless guitar + vocals video

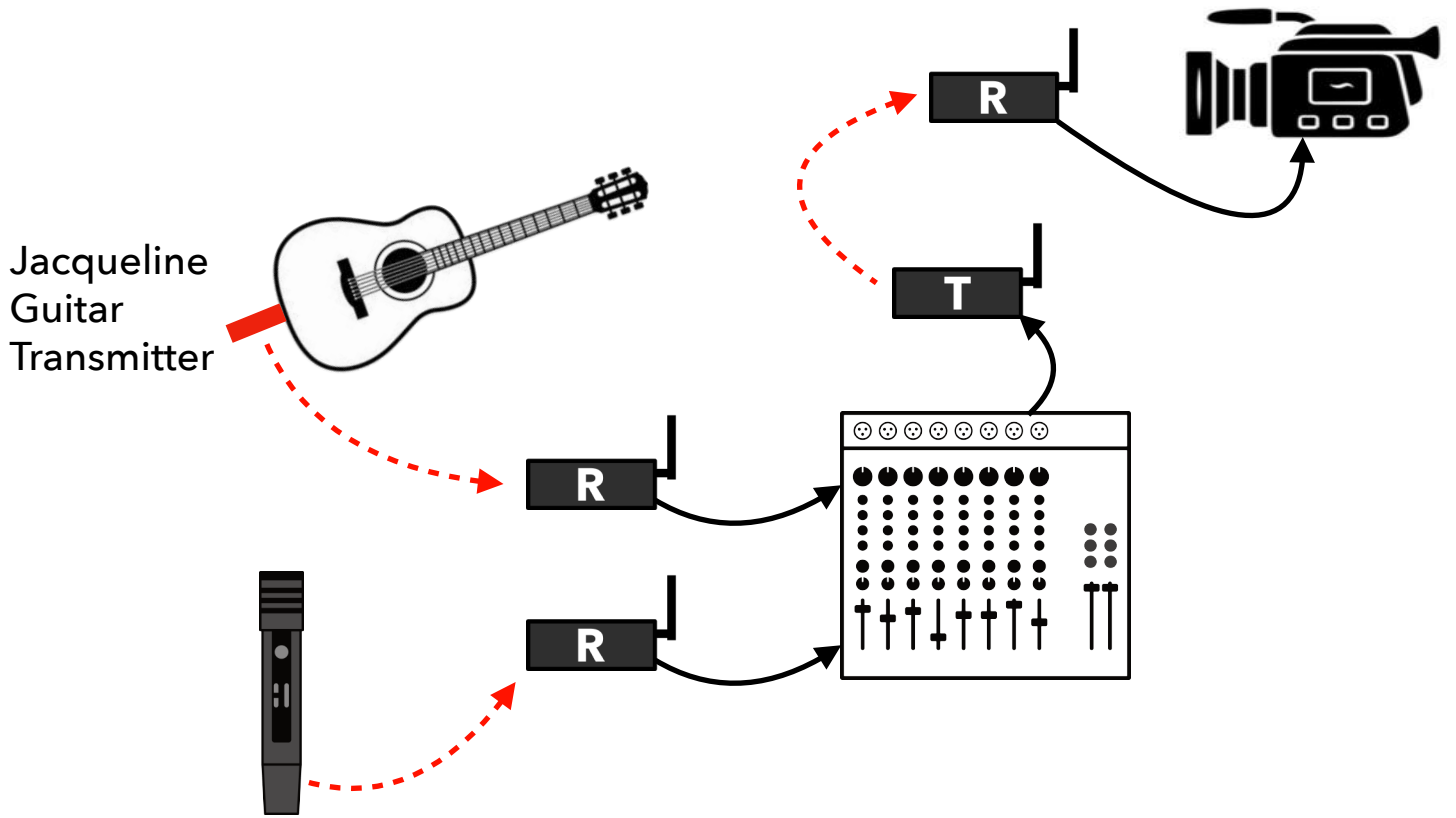

68

Wireless piano + vocals video

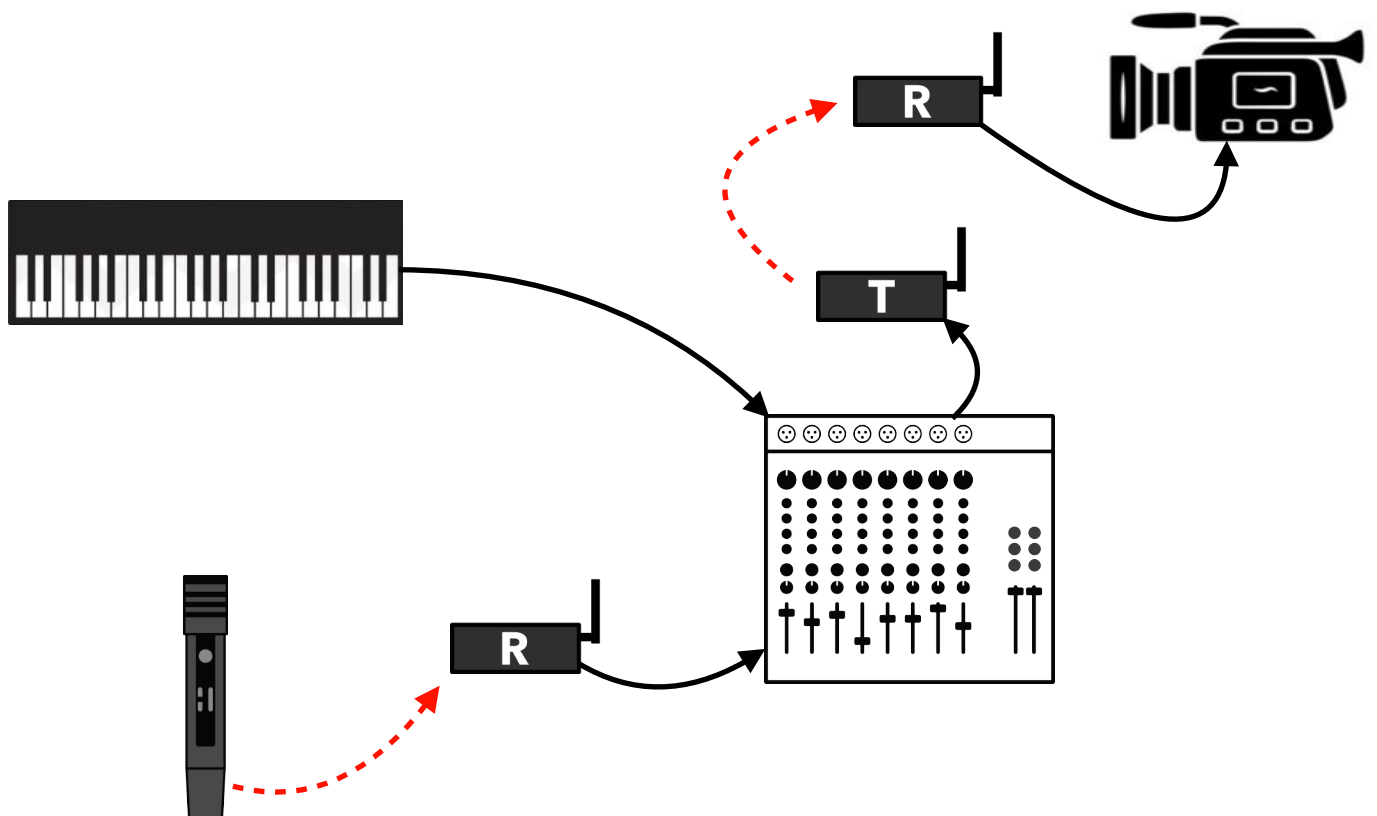

69

Singing video with backing track

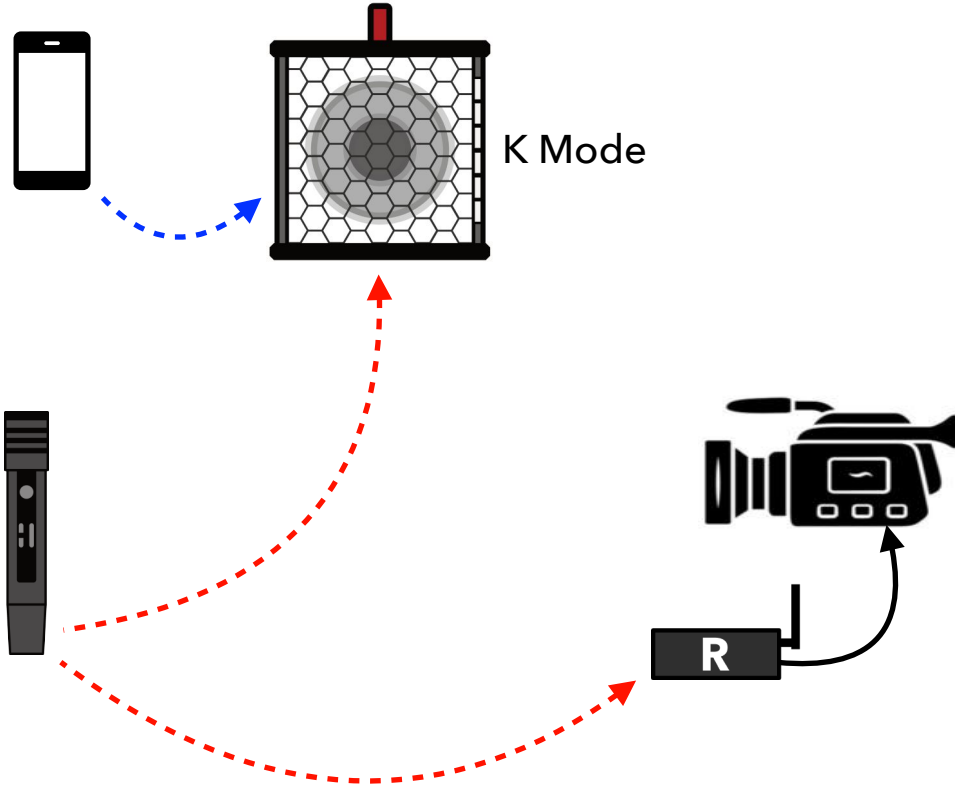

70

Singing video with backing track II

