

Death From Below Owner's Manual



SKAA[®] Pro Subwoofer



we hatched SKAA's thousand-pound gorilla sub in Canada
then we squeezed it down to 34 lbs in a plasma furnace

DILLINGER LABS

introduction

Thank you for choosing Death From Below ("DFB") by Dillinger Labs, the world's first SKAA / SKAA Pro battery subwoofer for mobile PA.

- Feed DFB from Dani transmitters, Soundboks 3, 4 & Go speakers, other SKAA Nadja Hub speakers, as well as any of the many types of SKAA /SKAA Pro transmitters found on SKAAstore.com
- Pro-grade SKAA wireless audio. 100% Bluetooth-free. 100% WiFi free.
- Use up to 4 SKAA receivers (any combination of Death from Below and any other SKAA receivers) at the same time with any one SKAA transmitter
- Remembers up to 10 of your favorite sources
- Low latency – great for live performance
- Choose from 6 epic EQ presets including one specifically tuned for use with popular Soundboks speakers
- Configure DFB's audio routing from the front panel. Select from LEFT, RIGHT or MONO MIX audio. Set up two DFBs as stereo subs if that's what you want.
- DFB remembers your EQ and audio routing setups – they'll be active until you change them again.
- A built-in hybrid bank of ultra-fast film capacitors and low-ESR capacitors jacks up DFB's performance by giving its amps instant access to energy when needed; that is, by ensuring the amps are never starved for power – the resulting enhanced impulse response is what's behind DFB's extra-ballsy punch.
- Time Align function includes a phase flip option plus a selection of delays you can choose from
- Dual tuned ports extend DFB's bass response down to 25 Hz while maximizing SPL output
- Steel grills suck for subwoofers. They're heavy and they block around 30% of their surface area with metal material. They're a ball & chain on driver cone dynamics and what's worse, they waste battery energy as a result. So we ditched 'em. Instead, DFB's light-weight aluminum vanes enable 99.7% unencumbered airflow to and from the drivers and ports. DFB ships with 4 vanes for extra protection.
- Compatible with the (optional) SKAA cmd app

For the intrepid few who always wondered what this meant but were too busy kicking butt to ask ...



The SKAA® standard for wireless audio guarantees compatibility between all products bearing the SKAA Compatible Badge. It also guarantees product antenna performance by verifying reliable operating distance minimums have been met. SKAA transmitters work with iOS & Android mobile devices, Mac & Windows computers, televisions and any product having a line output, S/PDIF output or a headphone jack.

SKAA semiconductor components enable SKAA to be embedded in consumer audio and pro audio products. Not based on Bluetooth or WiFi, SKAA is a global standard built from the ground up specifically for audio. Learn more at www.SKAA.com

- Charge the internal battery and play DFB at full volume at the same time
- Internal battery charges from empty to full in 2.5 hours using the included 125W brick power supply
- Battery fuel gauge LED stack displays battery life remaining
- A system with two DFBs and two Soundboks 4s pole mounted atop the DFBs is an ideal setup for the gigging mobile DJ
- DFB is not just for Soundboks. Use DFB to complement virtually any full-range PA speaker. Also, any powered speaker (QSC, JBL, EV, Mackie, etc.) can be converted to SKAA wireless just by adding a pro receiver such as Streetheart

We like to make our products easy to use and DFB is no exception !

Yet, to fully unleash the potency of your brand new clawing, snarling beast, we vehemently advise you to read this Owner's Manual. Its pages are brimming with juicy morsels of invaluable insights, irreverent commentary, and other assorted nuggets of paradigm-altering revelation. We really put our foot in this one and we hope you love your DEATH FROM BELOW subwoofer as much as we do!

creating the clawing, snarling beast

We didn't just take an AC-powered sub and strap a battery on it – DFB is built and optimized from the ground up to be a battery speaker. In the world of battery speakers, bags of Watts is actually a bad thing. Imagine how long a 115 Wh battery would power a 3600 W speaker ... $115/3600 = 0.03$ hours. Even once you consider crest factor, you still end up at around 0.13 hours (8 minutes). Would you buy that speaker?

*Yeah no – the same rules don't apply. The challenge is how to take an amp rating like 144W and translate it into paint peeling SPL output – killer real world volume that rivals the 3600 W monster. It sounds like magic but it's a carefully choreographed dance of cutting edge electrical, acoustical and battery engineering which makes DFB awesome. Make no mistake, DFB's first impression on people is, almost invariably, "That thing is f*cking loud!". Maybe it IS like magic. We're super proud of DFB, as is probably painfully obvious to you by now. 😊*

To say we're honoured to have you as part of the family is an understatement. Our whole universe exists because of you. Thank you for your purchase! We're fanatics about one thing especially: making sure you're not just satisfied, but that you LOVE your new DFB. You should know that the people who support you are also part of the development team. If you love your DFB and especially if you don't, please reach out to us and share!

dillingerlabs.com/contact

... the DFB development team at Dillinger Labs

Getting Started

- Power DFB ON / OFF by holding the power button down for a few seconds
- A bright Green Power LED means DFB is on
- A dim Green Power LED means DFB is sleeping
- A bright Red Power LED means DFB is on and Bonded to a SKAA Pro Transmitter
- DFB has a local volume control knob that doubles as the Bond Button
- Turn the volume knob clockwise to increase the volume and counter clockwise to decrease it – 30 steps (clicks on the knob) will take you from zero volume to full up
- Watch the Bond Indicator as you turn DFB's volume knob – it will flash once for every one of the 30 steps - when it stops flashing, you've arrived at one extreme or the other
- Remember, the output level of DFB depends on both its Local Volume (DFB's volume knob) and the Global Volume set by the SKAA Transmitter (for example, Dani's volume knob)
- Global and Local volume example: say Dani is set to 50% and DFB is set to 80% then the net output level will be $0.5 \times 0.8 = 0.4 = 40\%$.
- Bond Button: Triple click (click 3 times, fast) to mute DFB's output. Triple click again to unmute.
- Bond Button: Double click to search for a new transmitter; one that's not on your DFB's Green List (favorites list). Once DFB has Bonded to a new transmitter, its Bond Indicator will glow bright Amber.
- Bond Button: Press and hold the Bond Button for a few seconds to add an Amber-Bonded transmitter to the Green List. The Bond Indicator will glow bright Green. DFB memorizes the transmitter as a "favorite" and will look for it specifically the next time you power on.
- See the included SKAA Receiver User's Guide for more Bond Button / Bond Indicator features and functions
- Death From Below will play nice with all the kids in the schoolyard. Other SKAA-based speakers including Soundboks 3, 4, and Go as well as non-SKAA powered speakers can benefit from the addition of DFB.
- Just add a Dillinger Labs Streetheart Receiver to any powered speaker to make it SKAA and SKAA Pro compatible
- DFB natively supports the professional Dani SKAA/ SKAA Pro transmitter as well as all other SKAA wireless audio transmitters and sources
- Check out the 68 "sweet hookups" – a collection of use case diagrams at the end of this manual – they're just the tip of the iceberg but we bet at least a few of them will inspire you to try some crazy-ass stuff with your DFB

Volume Knob: Rotate clockwise/ counterclockwise to adjust DFB's volume; this knob can also be clicked – it is the SKAA Bond Button, too

Bond Indicator: shows your Bond status with SKAA Transmitters

The Power LED is bright green (or red) when DFB is on and dim green when DFB is sleeping

Hold down the power / gear button for a few seconds to turn DFB on / off

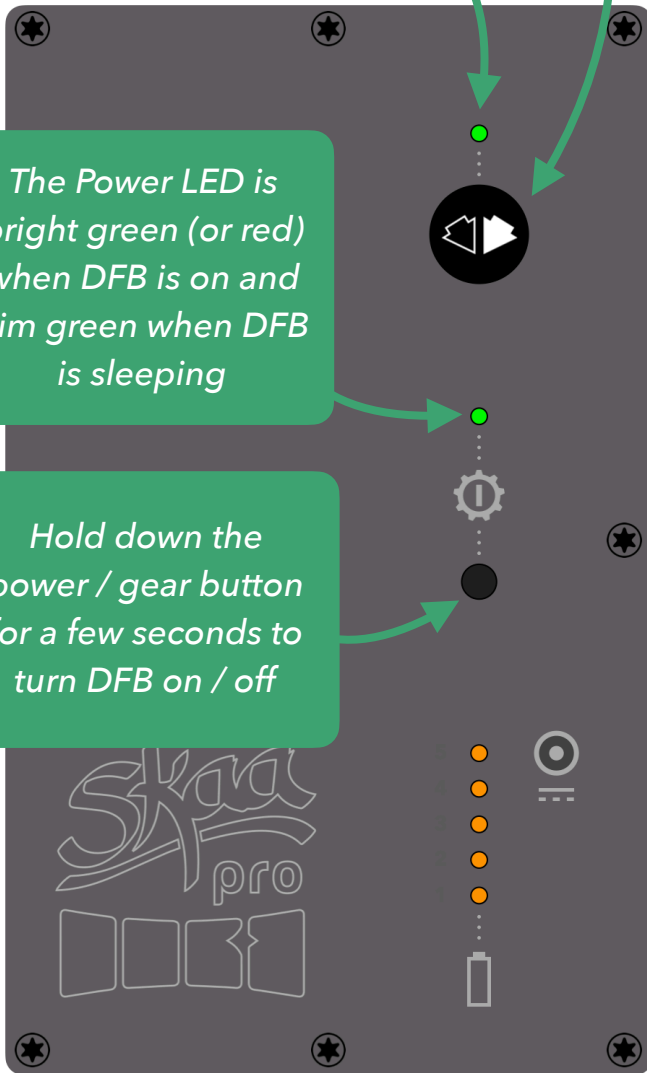

Battery & Charging

You can continue to use Death From Below while charging, even at full volume!

While DFB is powered on, click the Power Button once to display the battery life remaining

Power Jack - Use only the included 125W Brick Power Supply to charge DFB

this stylin' stack of orange LEDs is the Battery Fuel Gauge

- Death From Below runs for about 23 hours at normal listening level, or up to 40 hours at background level
- Some battery subs from well-known brands waste up to 20% of their battery energy in a voltage conversion process – we think that's nuts, so we don't do it that way. We chose DFB's audio amplifiers specifically so wasteful boost conversion isn't needed
- Use only the included Brick Power Supply for charging
- The battery will charge to full in about 2.5 hours (from fully depleted)
- You can use DFB (even at full volume) while charging
- The Battery Fuel Gauge (LED stack) gives you a visual indication of the amount of energy remaining in the battery – when activated, it stays on for a few seconds and then automatically shuts off
- To activate the Battery Fuel Gauge while DFB is powered on, click the power button once – this feature is disabled if external power is being supplied to DFB by the Brick Power Supply
- You will see the Battery Fuel Gauge activate whenever you power on DFB (so long as the Brick Power Supply is not connected)
- When about 3% battery capacity remains, the bottom LED in the Fuel Gauge stack will start to flash (that's the LED right above the battery icon) – no click on the power button is needed to get this "low battery" (flashing) alert
- DFB automatically powers off when the battery is fully depleted
- When DFB's battery is charging, the top LED in the stack (the one right beside the power jack) will glow – even if DFB is off
- Once charging has finished, the top LED in the stack will turn off, letting you know that DFB's battery is fully charged
- If DFB remains not Bonded to a SKAA transmitter for an extended period of time, it will enter a power saving sleep mode (DFB's power LED will be dim Green during sleep)
- If the Brick Power Supply is plugged in, DFB will stay in sleep perpetually until Bond is restored, but if the Brick Power Supply is NOT supplying external power, DFB will eventually power itself off
- Keep in mind that DFB's cascade into sleep and possibly auto off is triggered solely by loss of Bond
- Years down the road, your DFB may benefit from a new battery pack. We'll have replacement packs available on SKAAstore.com along with a helpful video on how to swap them.

the details ... sweated

a 72W amp for
this woofer

one-knob
control

plus another
72W amp for
this woofer

negative weight handles

6 EQ presets

honeycomb
rubber feet
compress to
eliminate wobble



POWER USER

Disconnect Brick Power Supply from DFB to use this function

while in EQ select mode, turn the volume knob to select one of six available EQ presets

double click the power / gear button to enter EQ select mode

the top 2 LEDs in the stack will flash to let you know you've successfully "2x clicked" and entered EQ select mode

watch the LED stack change as you turn the volume knob

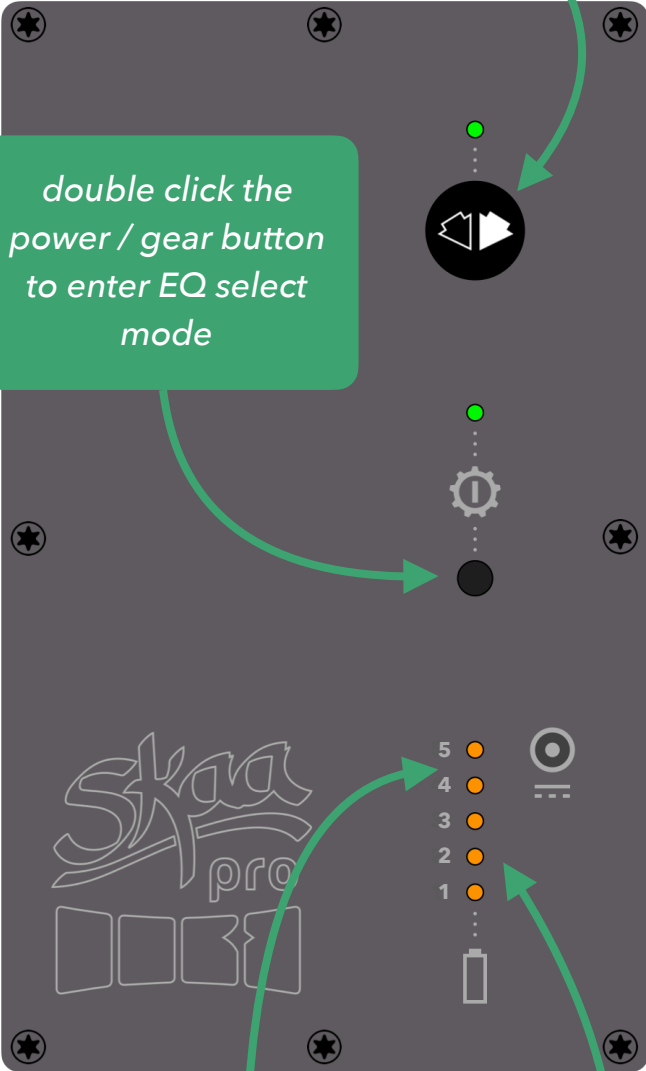

EQ select

- EQ select mode lets you pick from 6 different filter presets so you can customize your crossover point as well as the overall character of your DFB's sound
- Double click the Power/Gear button to enter EQ select mode (press and release twice, quickly)
- The top 2 LEDs in the LED stack will flash to let you know that your 2x click command was recognized and you're now in EQ select mode
- Turn the Volume Knob while watching the LED stack to rotate through DFB's six EQ presets

LED	EQ	DESCRIPTION
5	WIDE	Use this one when your full-range top speaker needs "all the help it can get"
4	OUTDOOR	Starts at 45 Hz to not waste battery energy on frequencies the outdoors will devour
3	SB++	Designed to compliment Soundboks speakers; has a VERY narrow bandwidth
2	PUNCH	Try this for Pop, EDM and other electronic genres – good for BASS-HEAVY styles
1	TIGHT	Rock, Country, Folk, Classical – good for all styles of music which are NOT bass heavy
OFF	BOTTOM	For the Studio when you really need to hear what's happening all the way down to 20 Hz

- EQ presets include both a high pass filter and a low pass filter, except for BOTTOM
- BOTTOM has no high pass filter added –its high-pass characteristic is therefore solely a function of acoustics and includes significant energy all the way down to 20Hz
- Experiment with all 6 EQ settings and trust your ears – remember, if it sounds good, it **is** good
- 10 seconds after you stop turning the volume knob, DFB will exit EQ select mode and return to normal operation
- DFB will remember your chosen EQ preset. Even if you power your subwoofer off and on, your selected EQ preset will remain active until you use this function to select another one.
- New out of the box, your DFB is set to PUNCH
- Doing a Factory Reset on your DFB (6x click on the Bond Button) will reset the EQ to it's Factory Default (PUNCH)
- See **Specifications** for the filter frequencies

POWER USER

Disconnect Brick Power Supply from DFB to use this function

while in Audio Routing mode, turn the volume knob to select one of three available routings

4x click the power / gear button to enter Audio Routing mode

the top 4 LEDs in the stack will flash to let you know you've successfully "4x clicked" and entered Audio Routing mode

watch the LED stack change as you turn the volume knob

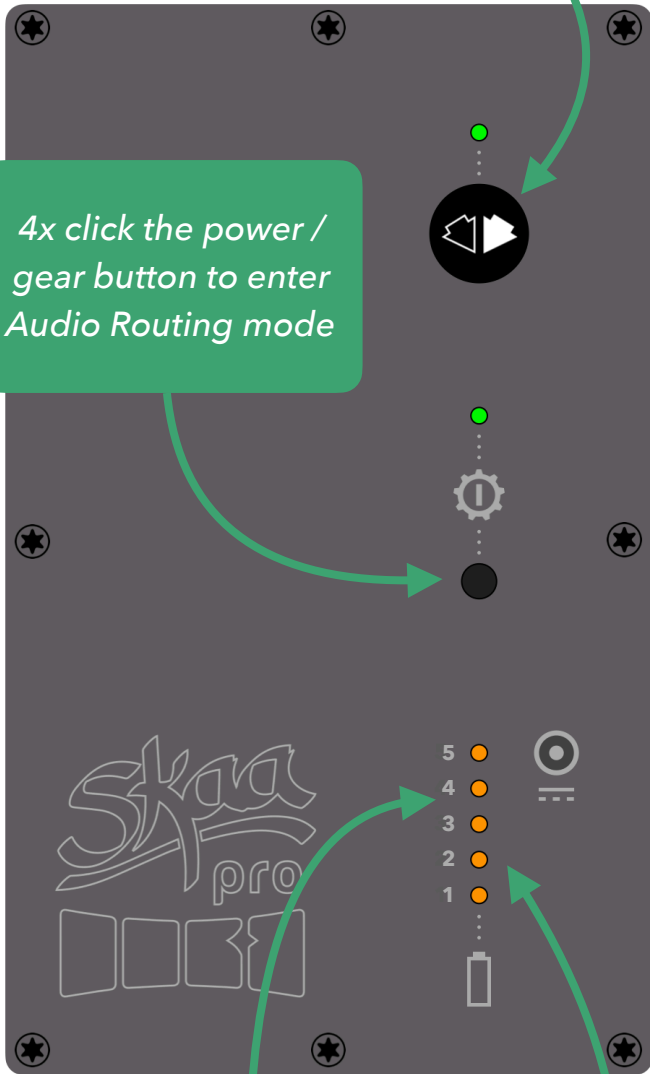

Audio Routing

- Audio Routing mode lets you pick from 3 different Audio Routing options
- 4x click the Power/Gear button to enter Audio Routing mode (press & release 4 times, quickly)
- The top 4 LEDs in the LED stack will flash to confirm your 4x click command was recognized and you're now in Audio Routing mode
- Turn the Volume Knob while watching the orange LED stack to rotate through DFB's three Audio Routing options

LED	ROUTING	DESCRIPTION
5	-	NOT USED
4	LEFT	SKAA channel 1 (LEFT) is routed to DFB's amplifiers and output
3	RIGHT	SKAA channel 2 (RIGHT) is routed to DFB's amplifiers and output
2	MONO	SKAA channels 1 & 2 (L & R) are mixed together, sent to DFB's amps and output
1	-	NOT USED IN DFB. In stereo devices like Streethart, the lowest LED means STEREO.

- Normally, you'll want to keep your DFB set to MONO routing (orange LED 2)
- If you have two DFBs, try setting up stereo subs (set one DFB's Audio Routing to LEFT and the other to RIGHT). Especially when used with an EQ preset like WIDE, stereo subs can sound epic. Try this with with 2 towers (2x Soundboks 4s pole mounted atop 2x DFBs). Just be sure you have a clean pair of underwear handy.
- Another reason you may want to set your DFB to LEFT or RIGHT is if you're transmitting 2 different audio programs on SKAA's 2 channels (for example, 2 different music playlists for 2 different rooms)
- 10 seconds after you stop turning the volume knob, DFB will exit Audio Routing mode and return to normal operation
- DFB will remember your Audio Routing setting. Even if you power your subwoofer off and on, your selected Audio Routing will remain active until you use this function to select another one.
- New out of the box, your DFB is set to MONO
- Doing a Factory Reset on your DFB (6x click on the Bond Button) will reset Audio Routing to it's Factory Default (MONO)
- The SKAA cmd app can also do this function

POWER USER

Disconnect Brick Power Supply from DFB to use this function

while in Time Align mode, turn the volume knob to select one of six available settings

5x click the power / gear button to enter Time Align mode

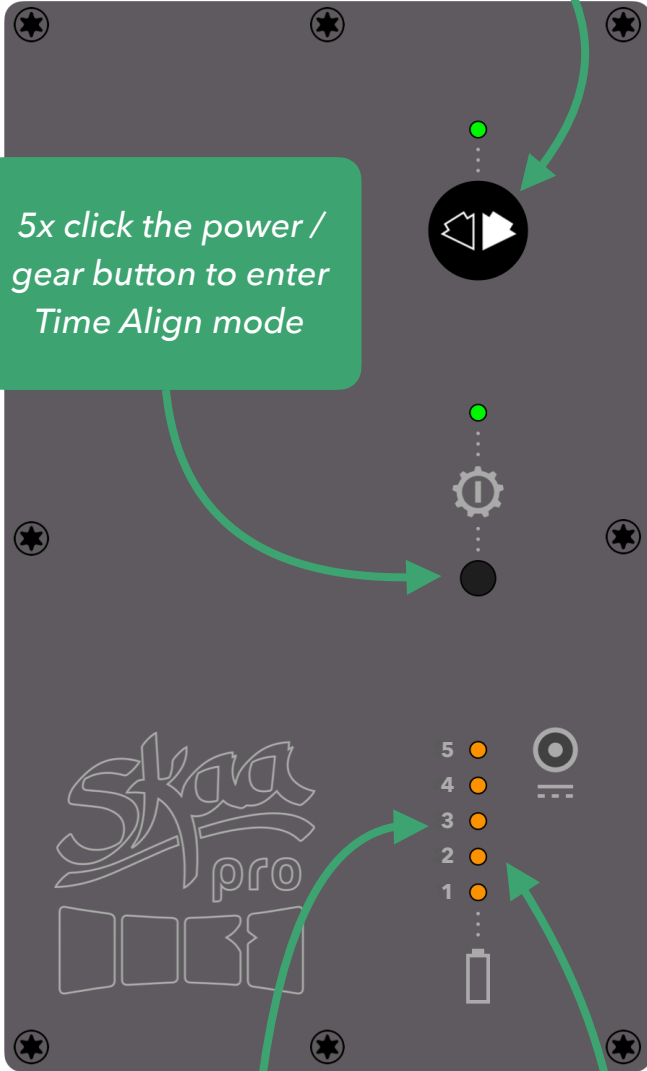

all 5 LEDs in the stack will flash to let you know you've successfully "5x clicked" and entered Time Align mode

watch the LED stack change as you turn the volume knob

Time Align

- Time Align mode lets you pick from 6 different phase and delay settings
- 5x click the Power/Gear button to enter Time Align mode (press & release 5 times, quickly)
- All 5 LEDs in the LED stack will flash to confirm your 5x click command was recognized and you're now in Time Align mode
- Turn the Volume Knob while watching the orange LED stack to rotate through DFB's six Time Align settings

LED	TIME ALIGN SETTING
5	add 11 milliseconds delay
4	add 7 milliseconds delay
3	add 4 milliseconds delay
2	add 2 milliseconds delay
1	180° phase flip (invert the output)
OFF	NONE

- Experiment with different settings to find what sounds good in your situation. Align with your top speaker bang on, or try the bass a few ms late for an epic "huge" sound. Trust your ears.
- With a Soundboks 3 pole mounted atop DFB, try settings 1, 2 or 3
- With a Soundboks Go pole mounted atop DFB, try settings 2 or 3
- With a Soundboks 4 pole mounted atop DFB, try settings 4 or 5
- With 2 DFB's, set one to OFF and the other to 1 (180° phase flip). Separate them by 1.5 meters and walk around the pair. It's a directional radiator which emits bass in some directions and not in others. Use it to "beam" bass to where you need it. Vary the distance between them to change which frequencies are beamed.
- 10 seconds after you stop turning the volume knob, DFB will exit Time Align mode and return to normal operation
- Even if you power your subwoofer off and on, your selected Time Align setting will remain active until you use this function to select another one.
- New out of the box, your DFB is set to NONE
- Doing a Factory Reset on your DFB (6x click on the Bond Button) will reset the Time Align setting to it's Factory Default (NONE)

the cabinet

4 lightweight vanes protect DFB's drivers while enabling free airflow

1 3/8" (35mm) top hat - welded steel, 4" deep & draft free

4 big rubber bumpers on DFB's rear wall help during transport & storage

12 mm baltic birch plywood cabinet with gorgeous black speckle coat finish



monkey grip handles reduce weight

dual tuned ports extend bass down to 25 Hz

dual 8" bass drivers enable a low cabinet profile

25 mm thick honeycomb-cell rubber feet compress & self level

- DFB's cabinet is built from high-grade 12mm birch plywood making it both tough and light weight. It has doubled-up side walls for extra strength and rigidity. An internal support at its center guarantees that DFB won't flinch even with heavy top speakers pole-mounted – or when the huge guy at the rave decides to use it as his personal dance platform.
- 5 of 6 of DFB's birch plywood walls are featureless – so 5/6 walls are pretty much impervious to impact damage
- Gorgeous and robust speckle-paint matte black finish – yes, the classy one – it's beautiful, tough and LIGHTWEIGHT
- DFB's huge honeycomb-cell rubber feet compress to prevent DFB from wobbling, even when placed on most uneven surfaces
- Big rubber bumpers on DFB's back wall protect the cabinet during transport and storage

- Pop an industry-standard 1 3/8" (35mm) pole (not included) into DFB's top hat pole bushing and loft a Soundboks 3, 4, Go or virtually any other powered speaker up top – no tripod stand needed
- With its massive welded-steel 4" deep pole bushing, ultra wide stance and anti-wobble honeycomb feet, DFB is a mega-stable pole base for your Soundboks or other pro-grade full-range top speaker
- Two monkey grip handles enable serious manhandling while literally reducing DFB's weight at the same time
- Weather resistant – DFB is good to go, regardless of where and when your gig is happening
- Gorgeous 3mm-thick anodized aluminum control panel. It's hefty to make DFB tough, and it doubles as a massive heat sink for DFB's audio amplifiers. With a heat sink this big, DFB can actually deliver the full rated amplifier wattage to your cottage.

all about the Volume

- Twist the volume knob – it controls DFB’s local volume (the volume of just this speaker)
- It will take you from 0 to full up in 30 steps (watch the Bond Indicator blink with each step)
- Keep in mind there’s a global volume, too, which lives in the SKAA transmitter. It’s the volume of the whole SKAA cell – it affects every speaker Bonded to the transmitter, not just this one
- The global and local volumes, multiplied together, are the volume you actually hear
- For example, if your local DFB’s volume is set to 50% and the global volume (the volume of the transmitter) is 80%, then the volume you’ll actually hear will be $0.5 \times 0.8 = 0.4$ or 40%
- Where do you control global volume? Well if you’re feeding DFB from a phone using a transmitter like Cassandra or Diz, global volume is tied to your phone’s volume – so adjust it using your phone’s volume buttons. If you’re using a pro transmitter like Dani, twist its volume knob.
- Some Hub speakers, when acting as SKAA transmitters, have global volume locked to full up. Others, give you a global volume control – check your speaker’s owner’s manual for details.

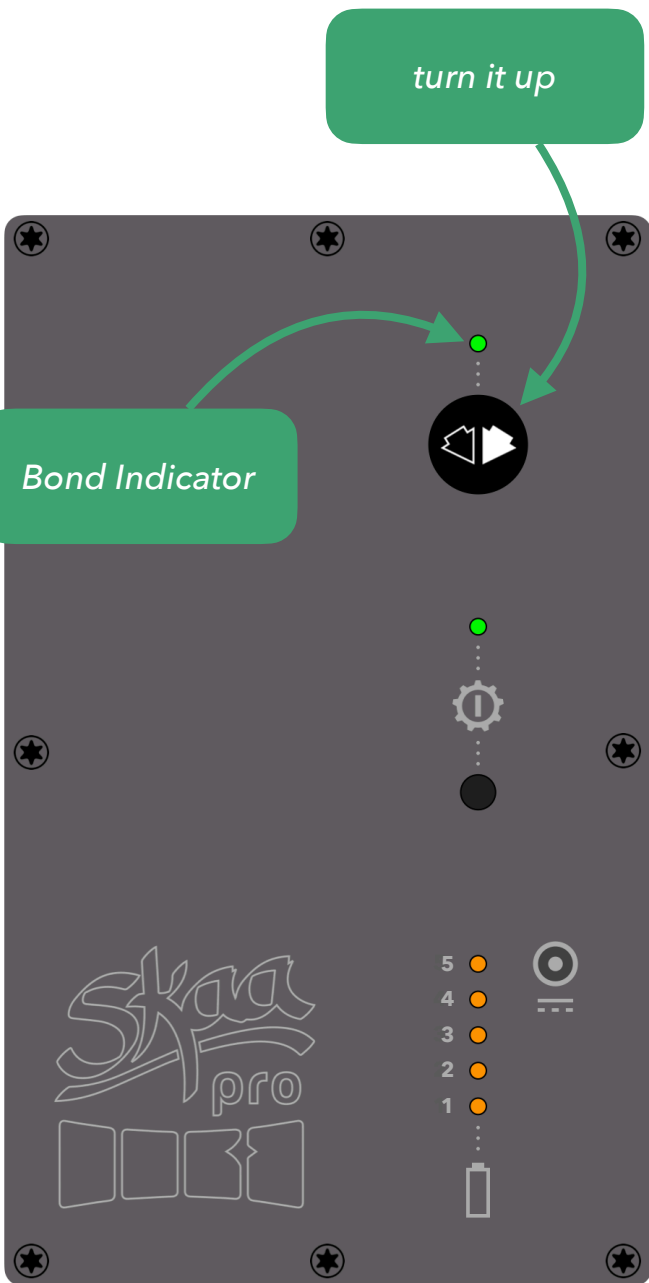

flirting with full Volume

- Full Volume can be defined as turning DFB up so loud that the audio sounds distorted (as in *bad*), then backing off one or two steps
- With bass-heavy music styles like EDM, you may notice you get to Full Volume WAY before DFB’s volume (global and local) is maxed out to 100%. This is *on purpose*.
- We wanted DFB to be usable for all music styles, including, for example, old rock which has very restricted bass content – not necessarily because the music producers wanted it that way, but because the target media, vinyl, could only handle so much
- So all this “extra gain” we made available on DFB isn’t there for the EDM / electronic styles – it’s there for all those bass-light styles
- Of course we could have just added heavy limiting to “homogenize” everything – which would have turned the EDM / electronic styles’ low end into bass mush – to which we said, “F-that”
- We decided instead to just make the extra gain available and explain why in this lovely manual
- So regardless of the style you love, just turn DFB up to Full Volume and let the flirting begin

SKAA cmd

SKAA cmd ("SKAA command") is The App You Don't Really Need. If you never download it, never install it, and never launch it, your DFB will still work just hunky dunky. But once you learn about what SKAA cmd can do, you might just *want* it...

SKAA cmd adds a long list of features to your SKAA setup. Use it with Cassandra, Diz and Ursula transmitters. Add custom names to Receivers, easily mute any or all of your Receivers, adjust individual volumes, see which Receivers are Bonded to your Transmitter and more.

The SKAA cmd App is available for iOS, Android, Mac, and Windows. Download it from Apple's App Store, Google Play, and at SKAA.com/TLC.

Check out the SKAA cmd App User's Guide, also on SKAA.com/TLC.

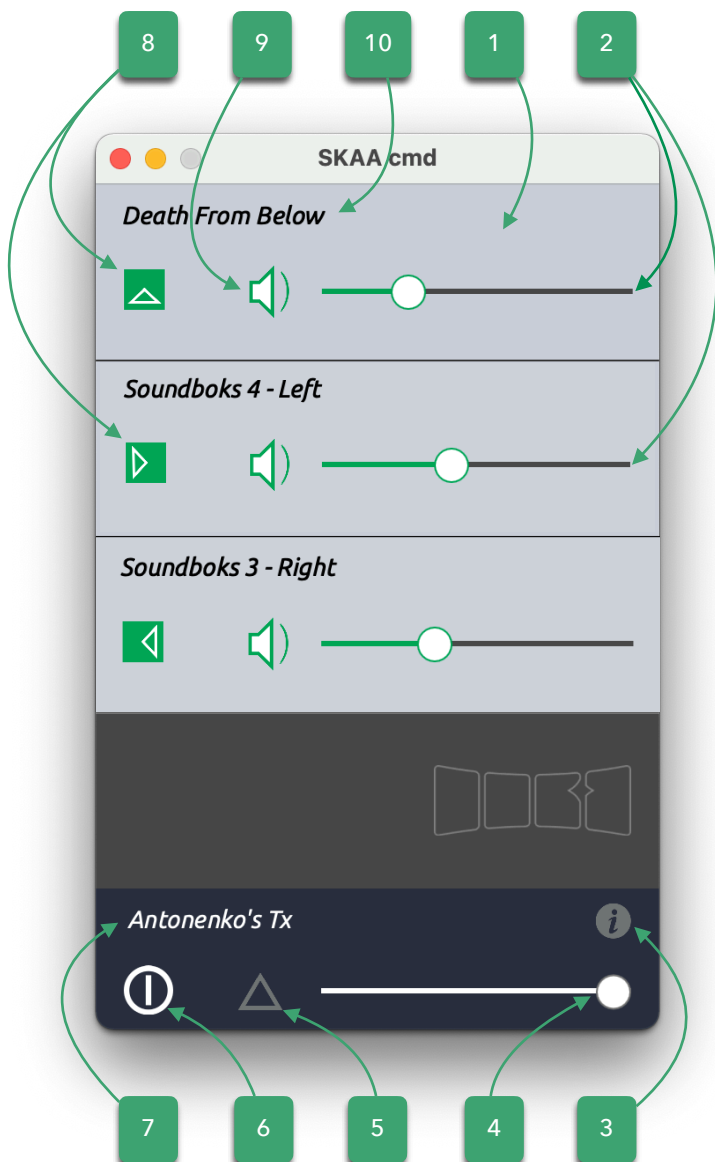

1. Each Transmitter has 4 bays and you can Bond a single Receiver or a Cluster into each bay

2. Slide a fader to change the volume of a Receiver – its volume is also affected by 4.

3. Click the "i" ball to see the SKAA cmd app version and the Transmitter firmware version

4. Global volume control. This fader affects volume on all Bonded Receivers.

5. Mute Macro: clicking this triangle is the same as individually clicking the speaker icon for each Bonded receiver – it's a quick way to mute all of them. Press each Receiver's speaker icon individually to unmute.

6. Transmitter Power Mode
RED: Always ON
GREY: Always OFF
WHITE: ON only when there is audio

7. Click to change the name of your Transmitter

8. Audio Routing: The Green Bond Block lets you choose whether a Receiver is playing Left, Right, Mono Mix or Stereo audio. Since DFB is a single-channel device, the stereo option is hatched out (disabled in DFB). From the factory, DFB is configured for Mono Mix audio (that's the icon with a downward firing speaker). Make one DFB Left and another DFB Right if you want stereo subs.

9. Click to mute this Receiver. Click again to unmute.

10. Click to change the name of your Receiver

specifications

Parameter	Conditions	Value
Cabinet Construction		12mm birch plywood construction with black speckle coat finish
Battery Capacity		115 Wh, 12-cell Li-ION built-in battery pack
Run Time	Normal / Background listening	23 Hours / 40 hours
Run Time	Full Volume	3.5 Hours
Charge Time	From Empty	2.5 Hours
Amplifier Power		144W RMS (2 x 72W Infineon Merus Amplifier ICs)
Amplifier Type		Multi-rail Class D
Heat Sink	Direct connected by aluminum block	215 x 130 x 3 mm aluminum plate to amp heat sink
Woofers	each woofer	8" diameter, rubber surround, 80W continuous power, 120W peak power
Woofers Impedance	each woofer	4Ω
Punch Enhancement		3 x 100V 15uF film caps + 5 x 1000 uF lo-ESR caps
Port		Dual Tuned Bass Reflex Ports
Frequency Response	Reference: 75 Hz at 1W, AES17 LPF	25Hz - 180Hz +/- 3 dB
Acoustical Max Level		122 dB SPL
THD+N	30Hz - 150Hz	<0.01%
SNR	A-weighted, Ref: 1W at 75Hz	82 dB
Digital Resolution	each of 2 available channels	48 kSamples/s, 16 bit
Antenna Type		FE Model B0
RF Power	Maximum	+18 dBm
Wireless Range	Actual range depends also on the actual antenna performance of the transmit-side SKAA device	Up to 50 meter reliable range
Inputs		SKAA or SKAA Pro wireless audio source
Standard Compatibility	SKAA OS 2.1 and later	Any SKAA or SKAA Pro Transmitter, any Nadja Hub
Transport Latency	I2S Digital to I2S Digital, SKAA	36.71ms +/- 1.5 samples
(cont.)	I2S Digital to I2S Digital, SKAA Pro	19.39ms +/- 1.5 samples
Max Receivers	Concurrent per Transmitter	4 (with SKAA source) , 2 (with SKAA Pro source)
Dimensions With Feet (HxWxD)		10.8 x 24.3 x 19.5 inches 27.4 x 61.7 x 49.5 cm
Dimensions W/O Feet (HxWxD)	Cabinet only, without bumpers and feet	9.8 x 24.3 x 18.7 inches 25 x 61.7 x 47.5 cm
Mass - Metric	Anywhere	15.5 kg
Weight - Imperial	near the Earth's surface	34 lbs
Power Supply Rating	External floor brick type	Input: 100-240 VAC, 50/60Hz, Output: 26V 125W

specifications (cont)

EQ Preset	High Pass Filter	Low Pass Filter
5 "Wide"	30 Hz Chebyshev Type 1	180 Hz Butterworth
4 "Outdoor"	45 Hz Chebyshev Type 1	160 Hz Butterworth
3 "SB++"	33 Hz Chebyshev Type 1	65 Hz Butterworth
2 "Punch"	36 Hz Chebyshev Type 1	90 Hz Butterworth
1 "Tight"	28 Hz Chebyshev Type 2	100 Hz Butterworth
0 "Bottom"	None	85 Hz Butterworth

important information

Read the following information carefully. Failure to follow these safety guidelines may result in personal injury or user dissatisfaction.

1. Do not poke the woofers. They don't like it.
2. Never place anything into DFB's tuned ports. If it's raining, stack a little something under DFB's back feet to tilt it a bit – you want water running OUT of DFB's tuned ports, not IN.
3. Only use the provided Brick Power Supply for charging DFB.
4. Never store or operate DFB near a heat source.
5. Do not charge DFB during electrical storms.
6. If you're always using DFB with its Brick Power Supply plugged in, make a point of running it on its battery at least once a month. Down to 3 LEDs on the fuel gauge is enough. This will extend battery life.
7. Listening to DFB at maximum volume may lead to hearing loss or partial hearing loss. We do not recommend listening with volume over 80% within 4 meters of your DFB.
8. Not for use by children under the age of 12.
9. Any disassembly of your Death From Below subwoofer will void your warranty.
10. When using DFB with poles and top speakers, use only 1 3/8" steel poles from a brand you trust, and get your bud to help you loft that Soundboks.
11. Death From Below is not your brother, mother or your friend. You will love it but it may not love you back.

This Owner's Manual is being continuously improved with the most up-to-date and accurate information on DFB. Please check our [website](#) for the most recent version.

Have questions or comments about Dillinger Labs products? We want to hear from you! Reach out to us [here](#).



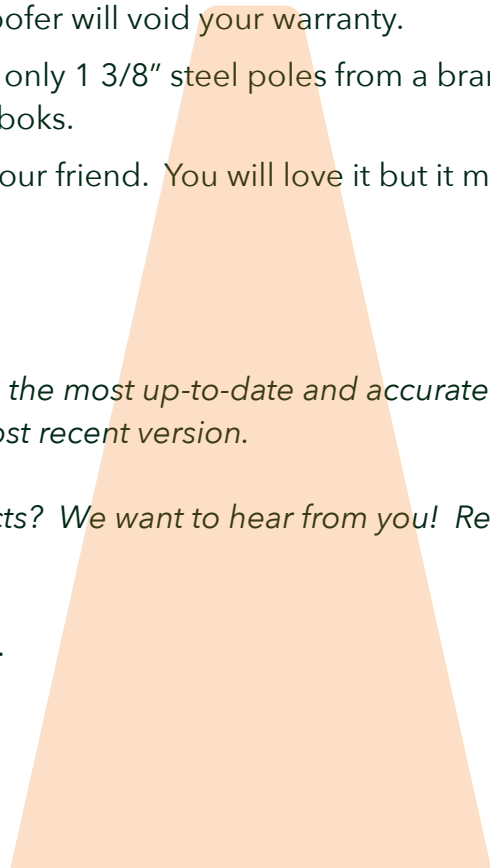







Check out SKAA's [YouTube channel](#) for great how-to vids.











SKAA® RECEIVER USER'S GUIDE

Each SKAA receiver uses a *Green List* to remember your *favourite* audio sources (SKAA transmitters). A Green glowing Indicator on your receiver means you are listening to a favourite, or hunting for one. You can also *explore* to find new transmitters—an Amber Indicator means you are *exploring* for transmitters which are not on your Green List. The  Bond Button on your receiver lets you select which audio source (SKAA transmitter) you're listening to.







Essentials

 Button	Command	Indicator
Hold a few seconds	<u>Add / Delete</u> Manually add / delete the current transmitter to / from your Green List	 to  = Added  (flash) = Deleted
-	<u>Auto Add</u> SKAA will automatically add the current Amber transmitter to your Green List if you listen to it for 30 minutes	 to  = Added
1 Click	<u>Green Mode</u> Rotate through your list of <i>favourite</i> transmitters (Green List) — when a favourite transmitter is found, the search stops and audio plays from that transmitter	 (dim) = Hunting  (flash) = Next one  (bright) = Bonded
2 Clicks	<u>Amber Mode</u> <i>Explore</i> for new, unknown transmitters (ones which are not already on your Green List)	 (dim) = Hunting  (bright) = Bonded

More Commands

 Button	Command	Indicator
3 Clicks	<u>Mute</u> do again to Unmute; any Click command will first Unmute and then do its function	 ,  or  = Muted (slow flash)
4 Clicks	<u>Red Mode</u> If you have 2 or more transmitters on your Green List, power on just the one you want to hear and it plays automatically.	 (dim) = Hunting  (bright) = Bonded
6 Clicks	<u>Factory Reset</u> Clear Green List. Start Over!	 (flash) = Reset Done
Hold during power on	<u>Make a Cluster of Receivers:</u> <ol style="list-style-type: none"> 1. Power off all transmitters and receivers 2. Power on the Master receiver while holding down its Bond Button—hold the button down until the Indicator begins to flash Red 3. With the remaining receivers within 3 meters of the Master receiver, power on the first one, wait for its Indicator to flash Red and then power on the second one; continue until all of them are powered on 4. Once all of the Indicators stop flashing (turn solid Red), power off all of the receivers 	 (flash) = Receiver has entered 'Cluster Up' mode  (bright) = The Cluster has been successfully made

QUESTIONS AND ANSWERS

Question	Answer
How does the Green List work?	You can store up to 10 SKAA transmitters on your Green List. These are your “favourite” audio sources. Every time you add a transmitter, it is assigned the first open spot on the Green List. When you single click the  Bond Button, the receiver hunts through the Green List much like a car radio hunts for radio stations when you press seek. If the Indicator is dim Green and flashes every few seconds, this tells you the receiver is hunting through the Green List. Say you have 5 transmitters on your Green List; your receiver will hunt through the list one by one: 1, 2, 3, 4, 5 and then back to 1 and so on. The dim Green Indicator flashes every time the receiver moves to the next spot on the list. This hunting goes on for up to 1 minute. If your receiver doesn’t find any of your favourite transmitters, it stops hunting and just waits for the last bonded favourite. If your receiver does find one of your favourite transmitters, the hunting stops, the Indicator turns bright green, and your receiver starts playing audio from that favourite. A dim Green Indicator that is NOT flashing means the receiver is just sitting on one spot, waiting for a specific favourite transmitter to show up.
How do I bond with a specific Green transmitter?	Play audio from your source device and ensure it has a SKAA transmitter connected. Click the  Bond Button on your receiver. The receiver hunts through the Green List, flashing the Indicator as it goes. Once your receiver finds one of your favourite transmitters, it bonds to it and plays audio from that transmitter. If that isn’t the transmitter you wanted, click the Bond Button once more. Repeat until your receiver bonds with the transmitter you want and you’re hearing the correct audio playing.
How do I select transmitters if I can’t reach my Bond Button?	Say you want to put your receiver on a high shelf where you can’t reach the Bond Button easily. First, set up your Green List: add all of the transmitters you’ll want to use. Then 4-click the  Bond Button to enter Red Mode. Now put the receiver up on the high shelf. Power on just one of your transmitters and power off all others. The receiver automatically bonds to the transmitter that’s on.
How do I delete a transmitter from my Green List?	Factory Reset (6 Clicks of the Bond Button) clears the Green List and lets you start over from scratch. If however, you’d like to delete just one transmitter from your Green List, first bond your receiver to the transmitter you wish to delete. See the section above: How do I bond with a specific Green transmitter? . Once you are bonded to it, hold down the  Bond Button for a few seconds until you see the Indicator flash Red –this Red flash means the transmitter has been deleted.
What is a Cluster?	Clusters are an optional convenience for “power users”. A Cluster is several SKAA receivers behaving as one product. A left & right speaker pair, for example, or a sound bar and subwoofer.
What is the Master receiver?	In any Cluster, there is a single Master receiver, and all of the other receivers in the Cluster follow its behaviour. You can control the entire Cluster by operating the  Bond Button of the Master. A receiver must have a physical Bond Button in order to become the Master.
How do I “uncluster” several receivers?	Do the Make a Cluster of Receivers procedure once for each receiver, but omit Step 3. Do them one at a time. This gives each of the receivers a functioning  Bond Button, and each of them will thereafter operate independently.
What are some tips for making Clusters?	Each step in the Make a Cluster of Receivers procedure has a 10-second time limit. When you see the Master’s Indicator start to flash Red, you have 10 seconds to power on the next receiver. When that receiver’s Indicator starts to flash Red, you have 10 more seconds to power on the next one, and so on.
Why does only one of my Bond Buttons work?	When you make a Cluster from several receivers, the first one powered on in the Make a Cluster of Receivers procedure becomes the Master of the Cluster. Only the Master’s  Bond Button works because a Cluster uses just one Green List –the Master’s Green List. The Bond Button of each of the other receivers will work only for the Mute / Unmute function (3-Click of the Bond Button).
Can any group of receivers be made into a Cluster?	No. The receivers must be members of the same product family. If they are not, the Make a Cluster of Receivers procedure won’t work. This is because only receivers which were designed to work together (as a single product) can be made into a Cluster.

setting up Soundboks speakers to work with your DFB

Hub speaker

Click the  button to set Soundboks' mode to:

Host

In this mode the Soundboks will act as a SKAA transmitter (what we call a Hub speaker) relaying its own audio to up to 4 additional Satellite Speakers (for a total of up to 5 speakers)

Satellite speaker

Click the  button to set Soundboks' mode to:

Join

Use the  Bond Button to connect this Satellite speaker to any SKAA transmitter, or to any Hub speaker (a Hub acts like a SKAA transmitter)

SKAA or SKAA Pro operation

- Use the Soundboks App on your phone to set your Hub speaker (Soundboks speaker in Host mode) to SKAA or SKAA Pro mode (all downstream Bonded speakers will automatically follow the mode of the Hub)
- SKAA mode – Bond up to 4 more speakers at standard low latency (for a total of 5 speakers in the SKAA cell)
- SKAA Pro mode – Bond up to 2 more speakers at ultra-low latency (for a total of 3 speakers in the SKAA cell)

Soundboks speaker models

- All of the following Soundboks speakers will work for the use cases described in this doc
- Soundboks 3
- Soundboks Go (will support all those use cases that do not depend on combo [XLR/TRS] jacks)
- Soundboks 4

Hub speakers have SKAA transmitters built in

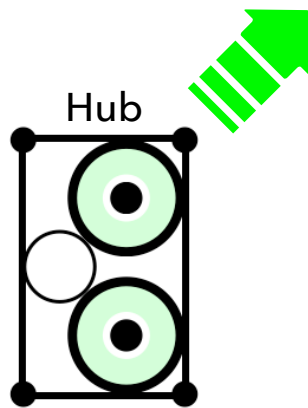

For example:

- Soundboks 3 (in Host mode)
- Soundboks 4 (in Host mode)
- Soundboks Go (in Host mode)*
- And many others
- They all support both bluetooth and wired sources

* Soundboks Go can serve as a Hub in all use cases that don't require TRS/XLR wired input

and you can always cook your own Hub ...

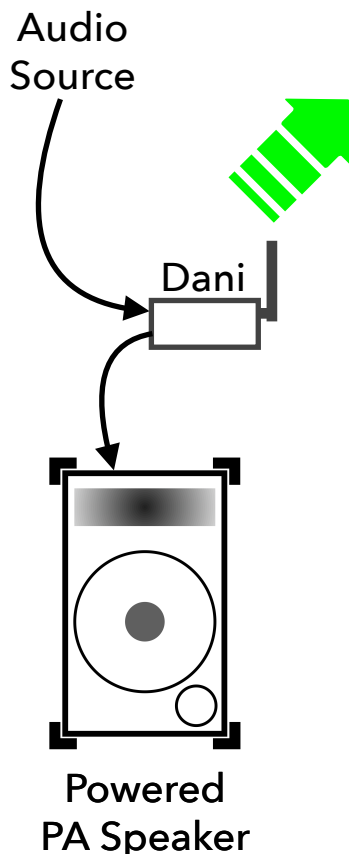

The do-it-yourself Hub:

- Use any powered PA speaker (Mackie, EV, QSC, JBL, etc.)
- Add a Dani SKAA/SKAA Pro transmitter
- Daisy chain your audio source into Dani's inputs and then out from Dani's thrus to the PA speaker (use TRS patch cables)
- Enables you to both hear the audio and transmit it to up to 4 Satellites

- Not as good as a speaker with SKAA Hub function built in (Soundboks 3, 4 and Go all have it built in) because:
- Bluetooth input not supported
- There's no latency compensation to exactly time align the wired speaker with the wireless ones

Satellite speakers have SKAA receivers built in

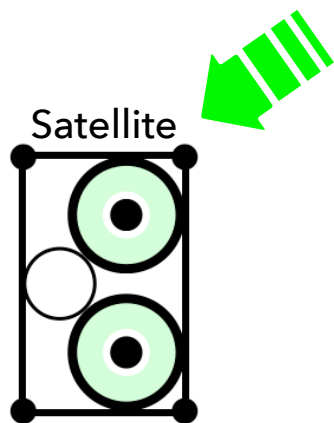

Satellite

For example:

- Soundboks 3 (in Join mode)
- Soundboks 4 (in Join mode)
- Soundboks Go (in Join mode)
- DFB itself is a satellite speaker!
- And many others

and you can always grow your own Satellite ...

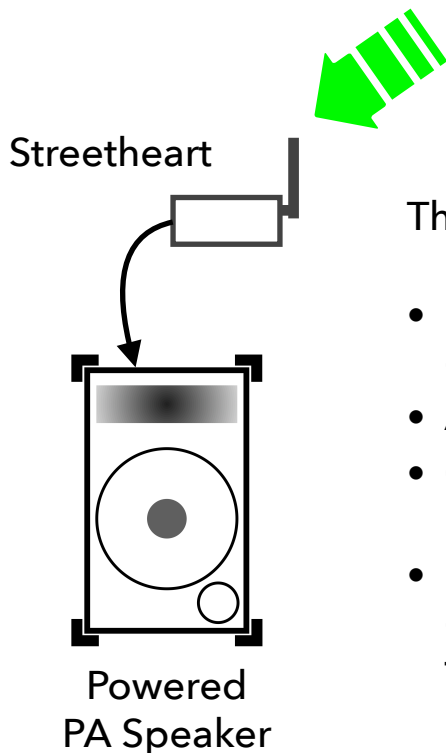

Streethart

The do-it-yourself Satellite:

- Use any powered PA speaker (Mackie, EV, QSC, JBL, etc.)
- Add a Streethart SKAA/SKAA Pro receiver
- Connect Streethart's outputs to the PA speaker using 2 TRS patch cables
- Not quite as slick as a speaker with SKAA receive capability built in (Soundboks 3, 4 and Go all have this built in)

Powered
PA Speaker

the sweet hookups: contents

Hookups	Use Case
1 - 12	Music & Party
13 - 16	Deckless DJ
17 - 20	Movies, TV, Social Media & Games
21 - 30	Instruments / Live Performance
31 - 34	Studio Recording
35 - 46	PA
47 - 54	Talk and Sing – Mics
55 - 58	Multi-person Jams
59 - 62	Pool & Yard
63 - 68	Pro DJ

The Hookups

1

you play music like this every day

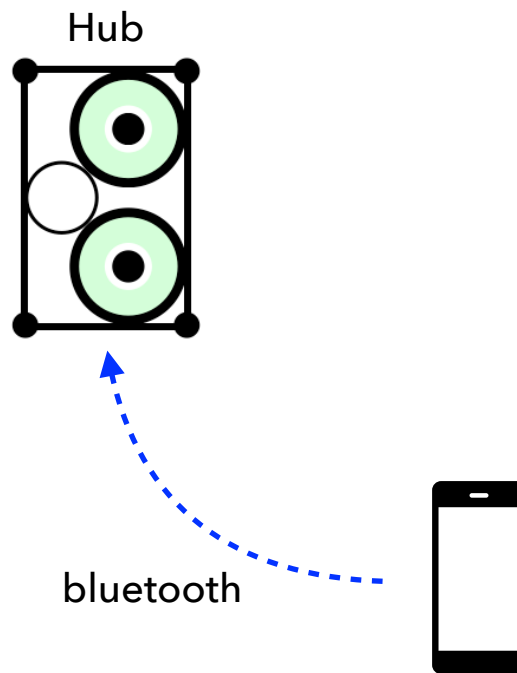

2

now pimp the bass ...

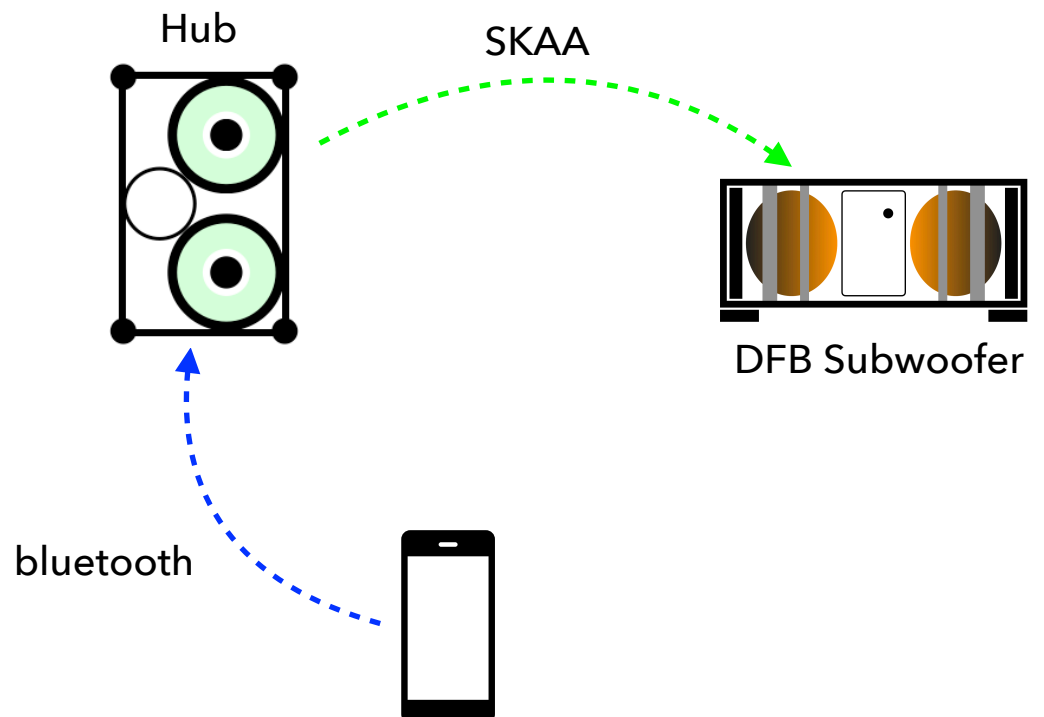

3

... the party setup

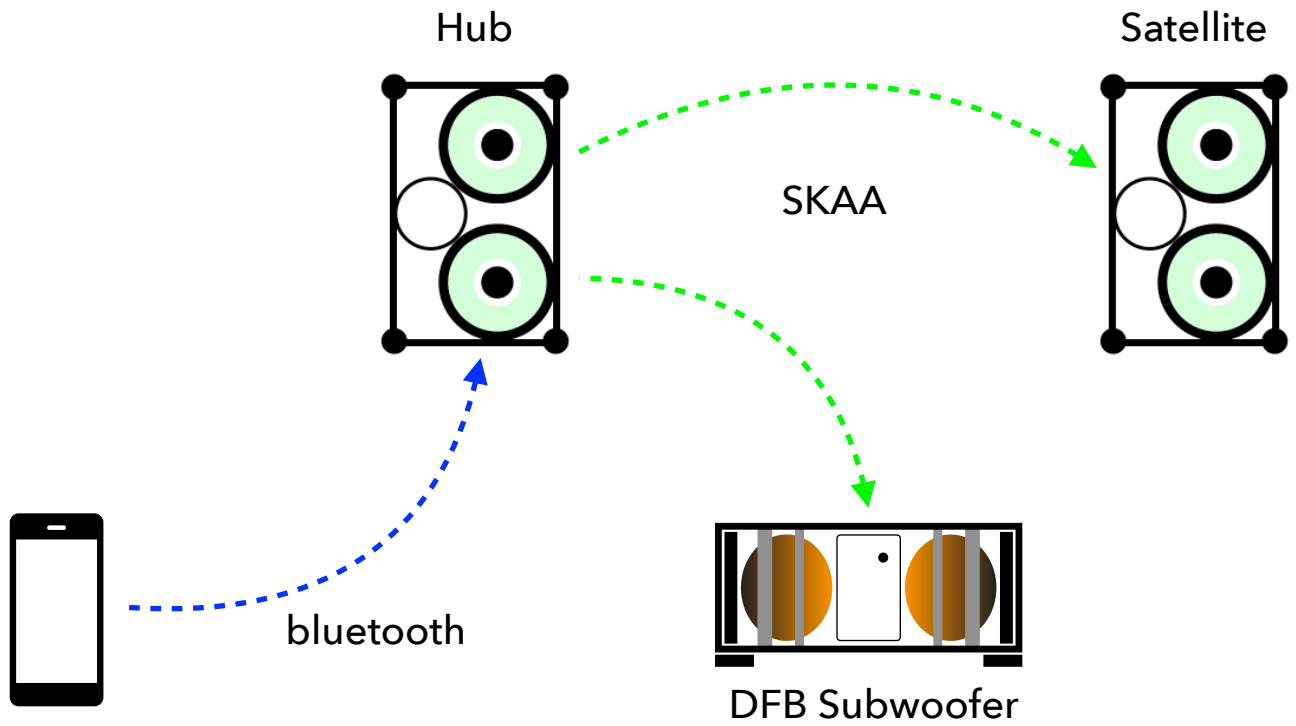

4

... maxed out

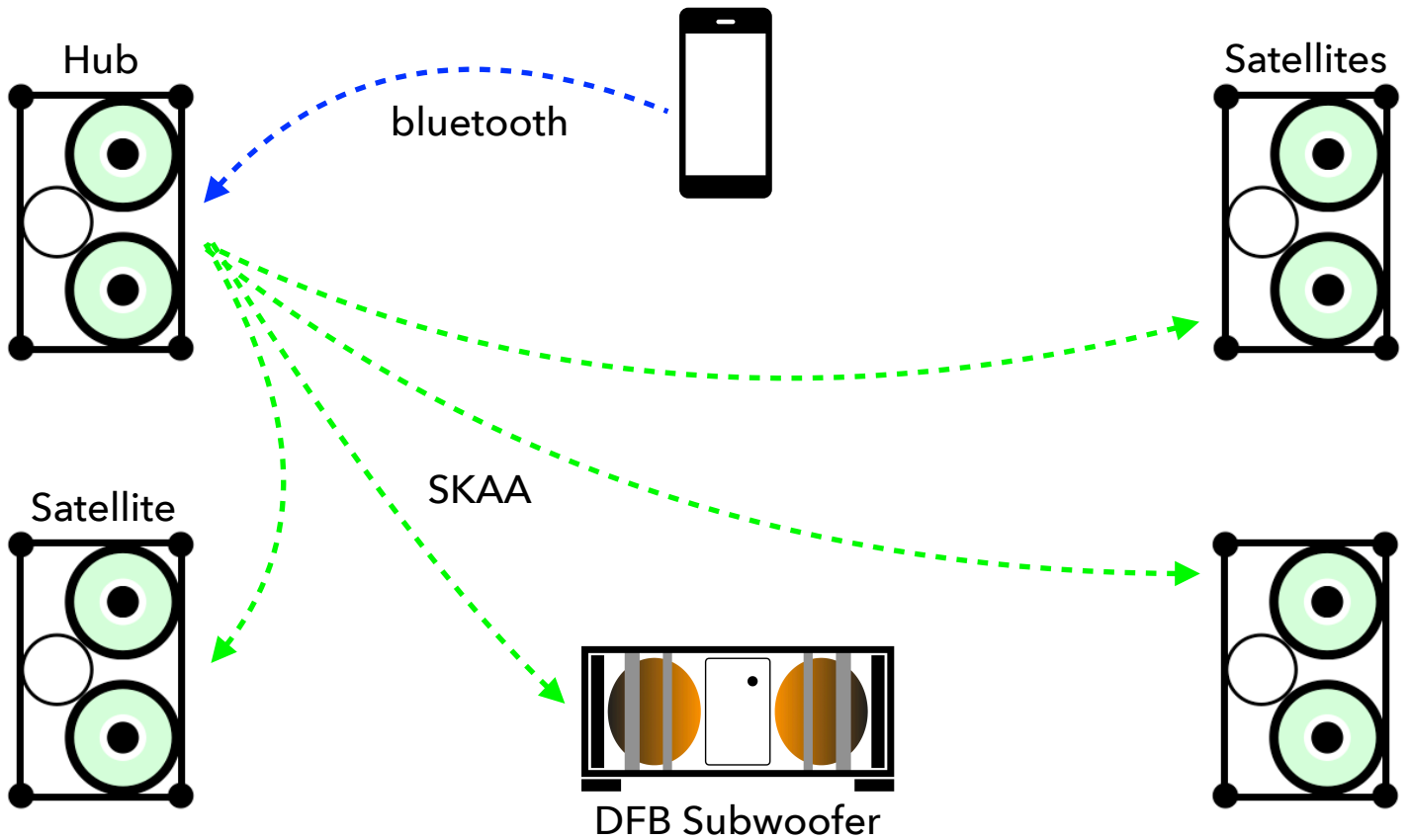

5

... more bass good

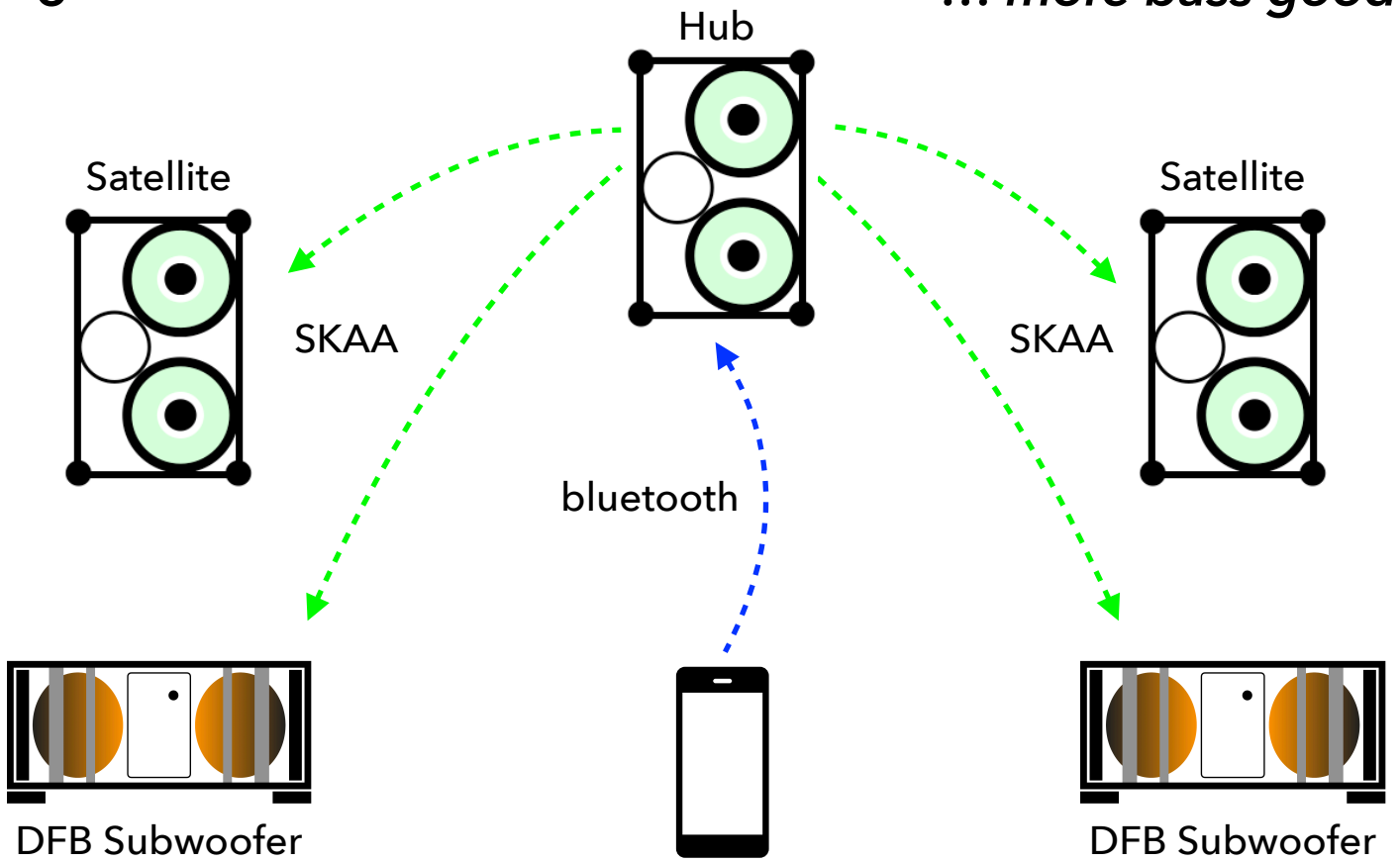

6

... meet the cops

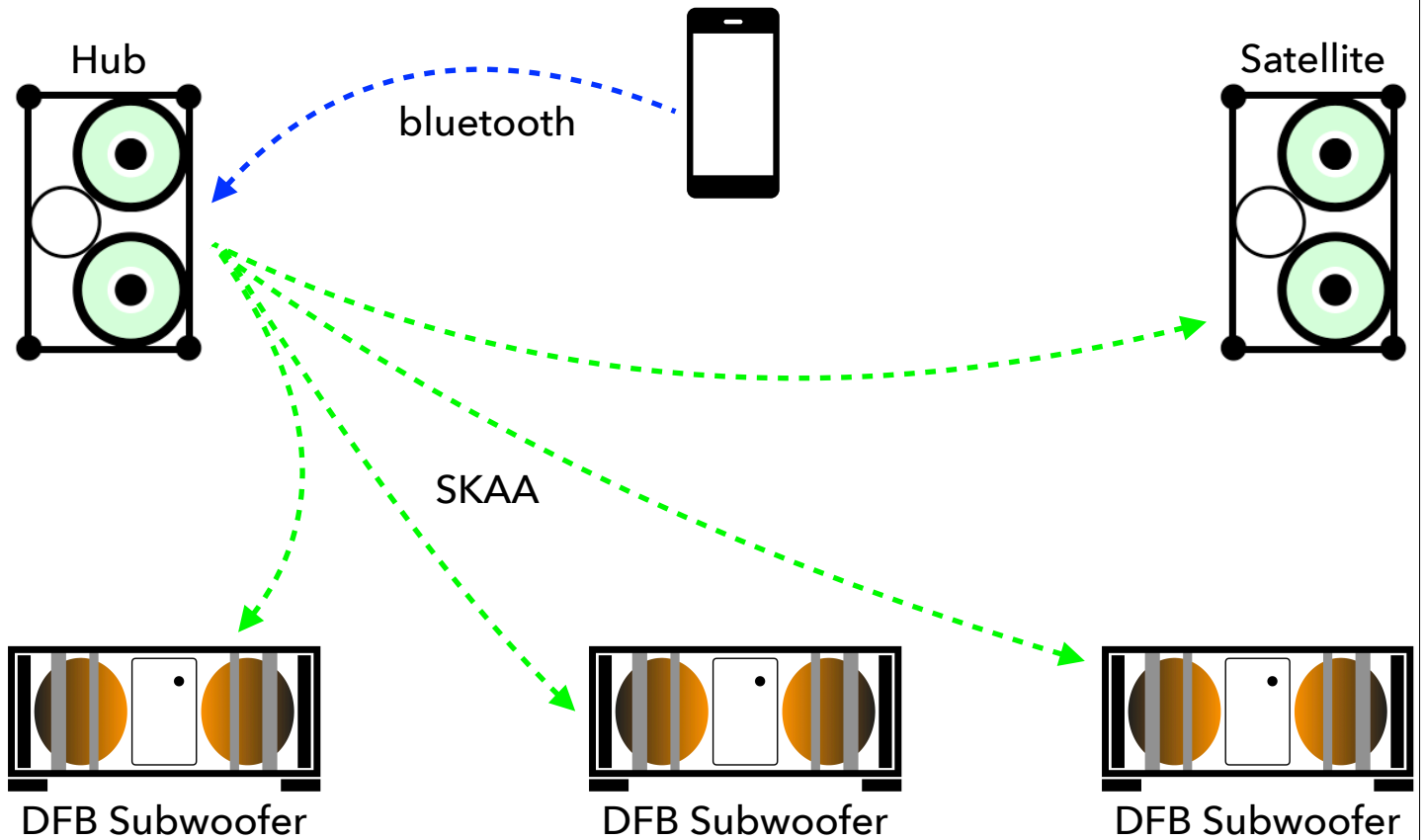

7

... pimp the fidelity I

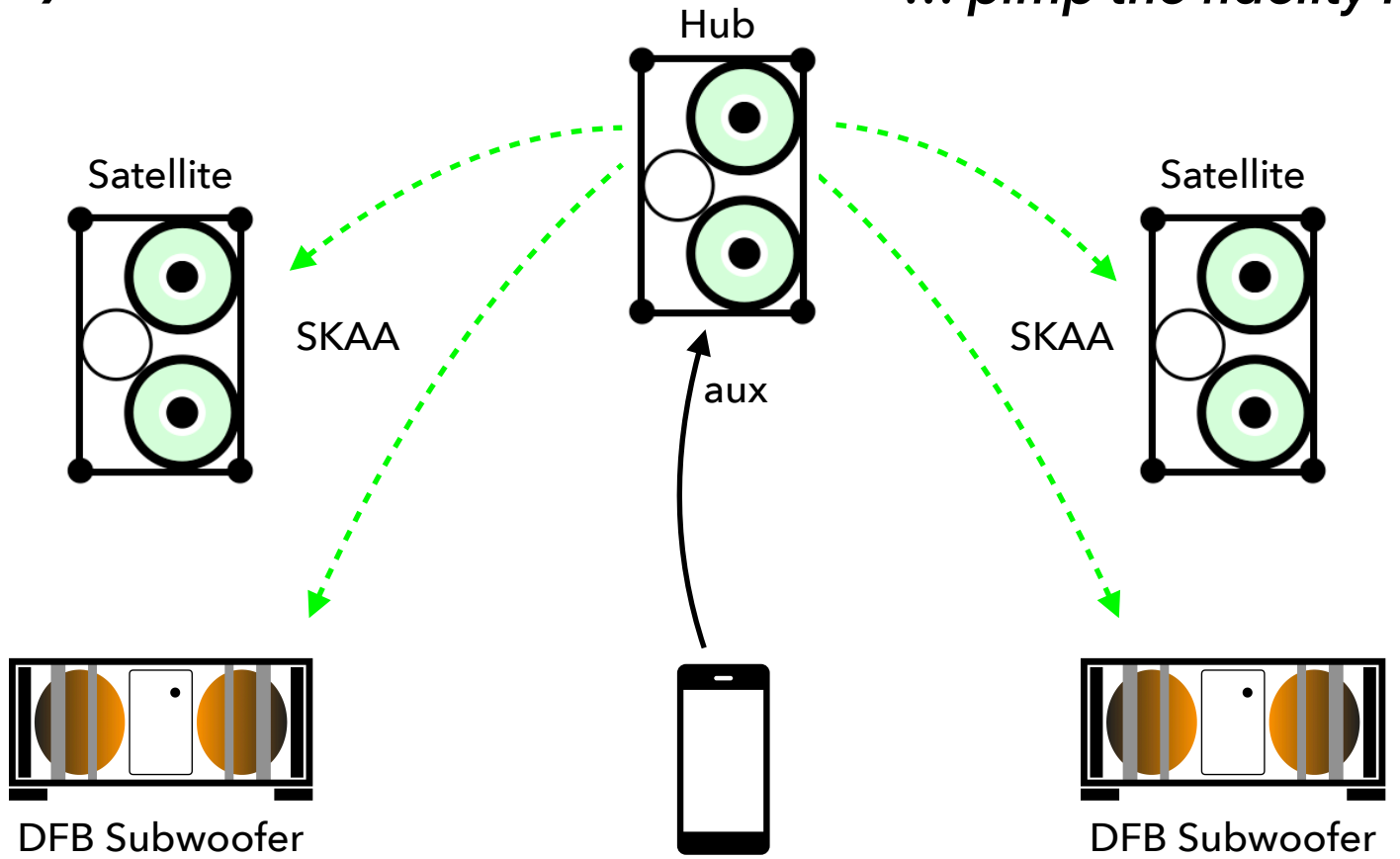

8

... pimp the fidelity II

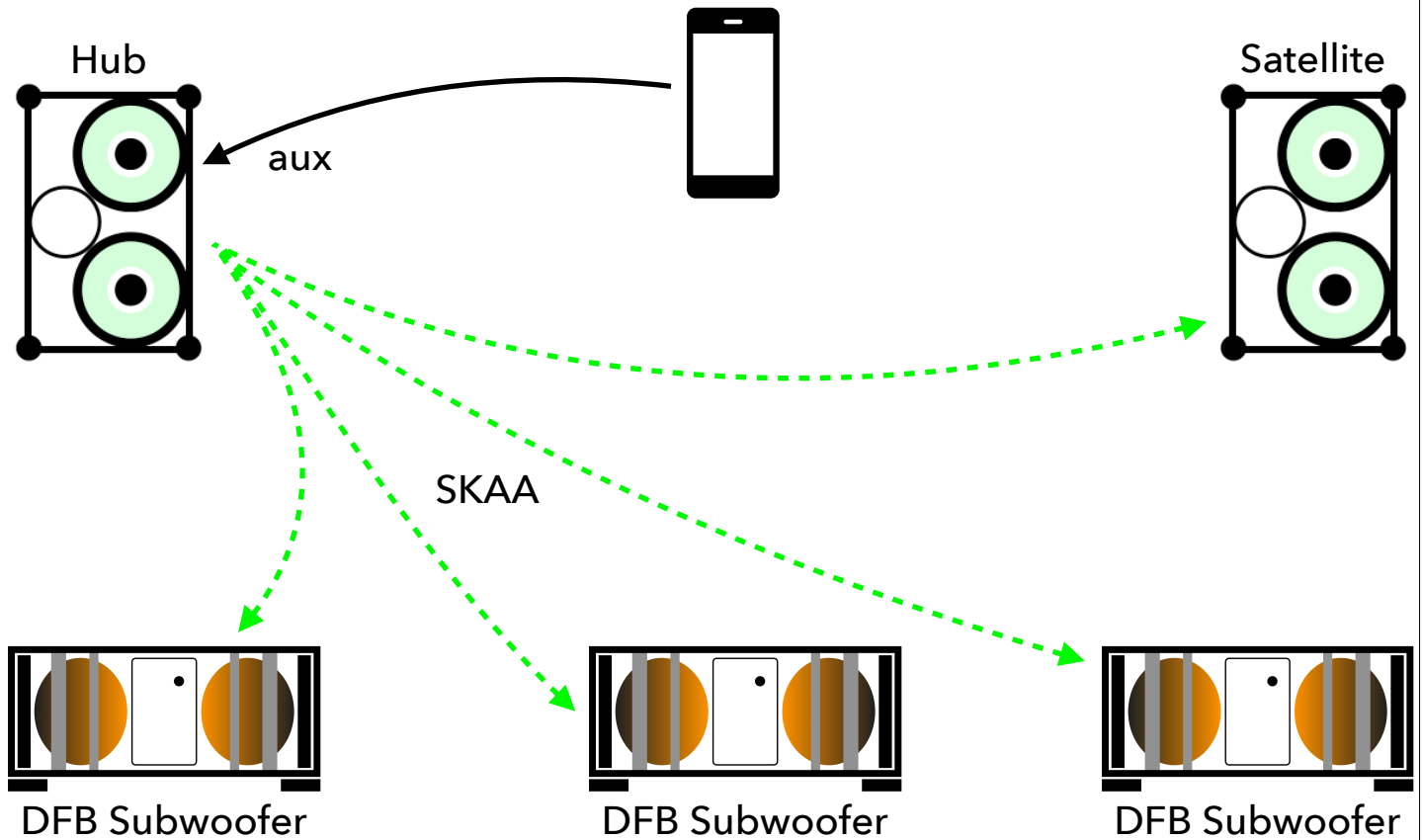

9

... ludicrous I

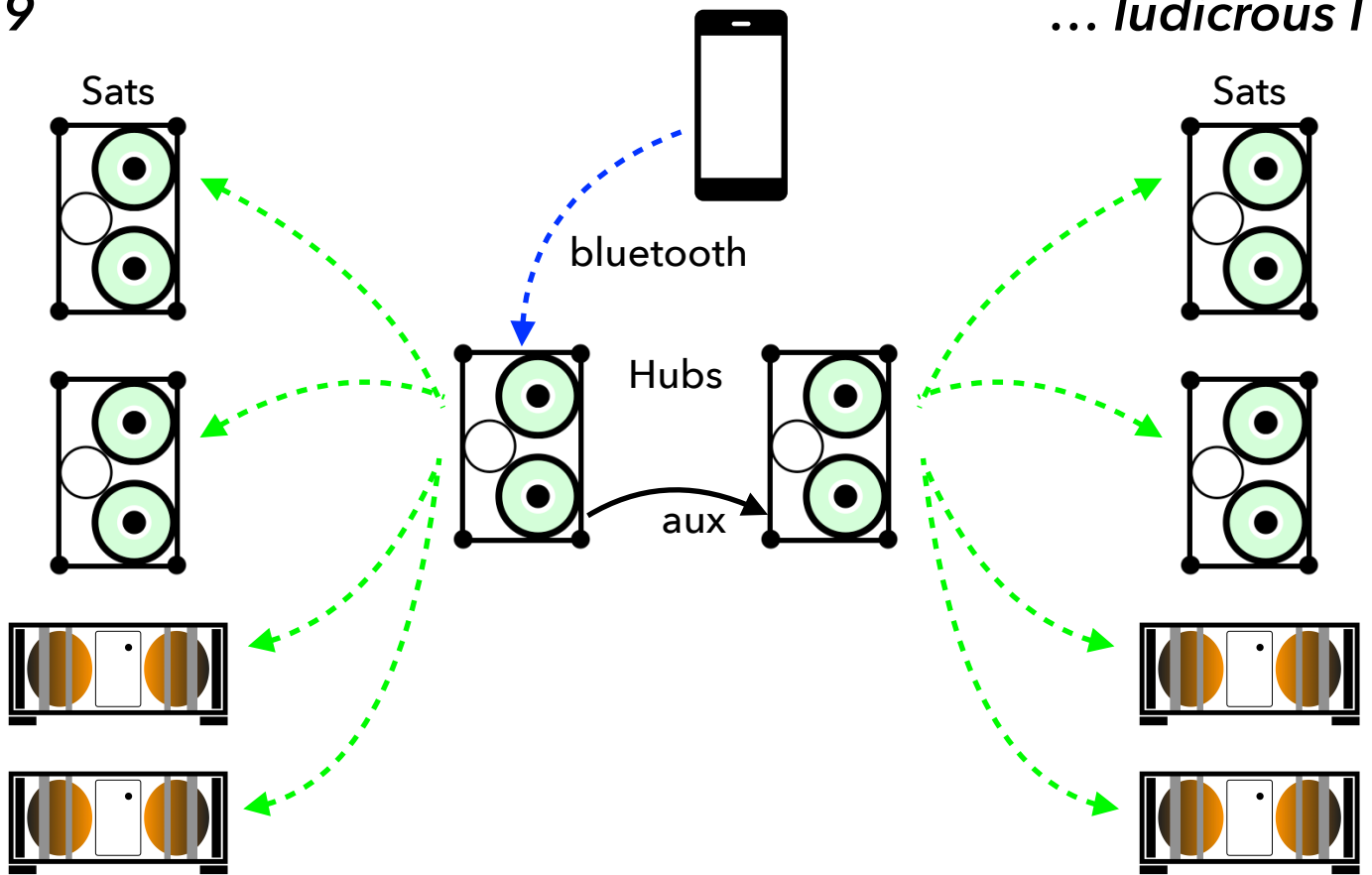

10

... ludicrous II

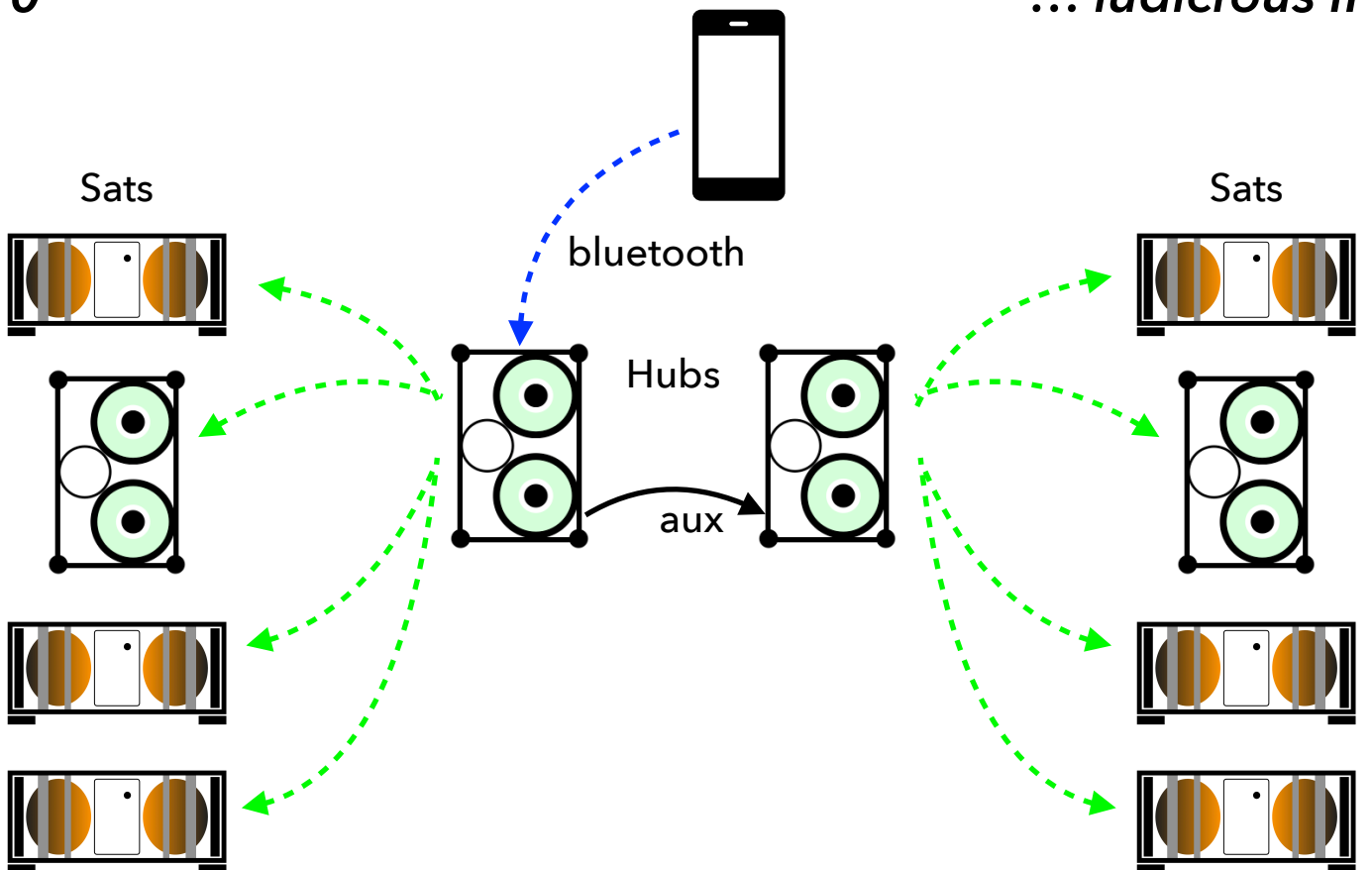

11

all of the above 10 hookups work with tablets, too

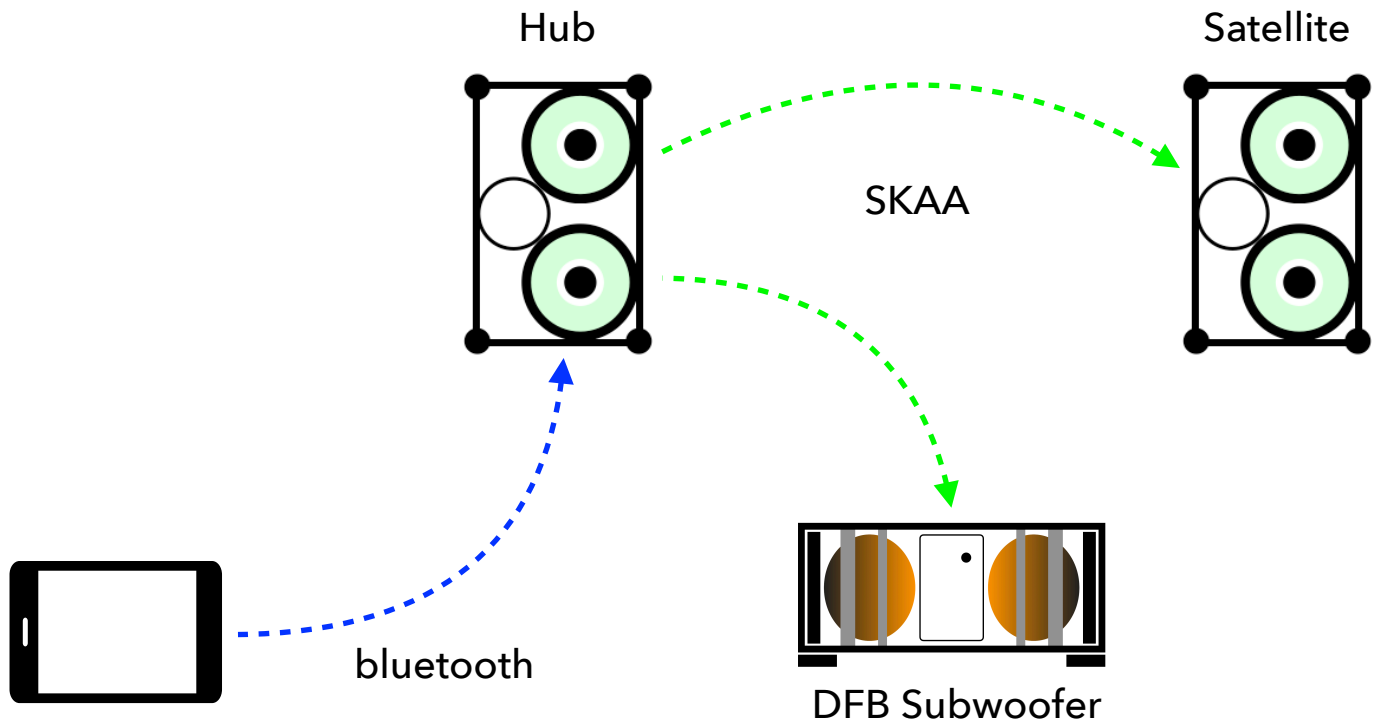

12

... and notebooks

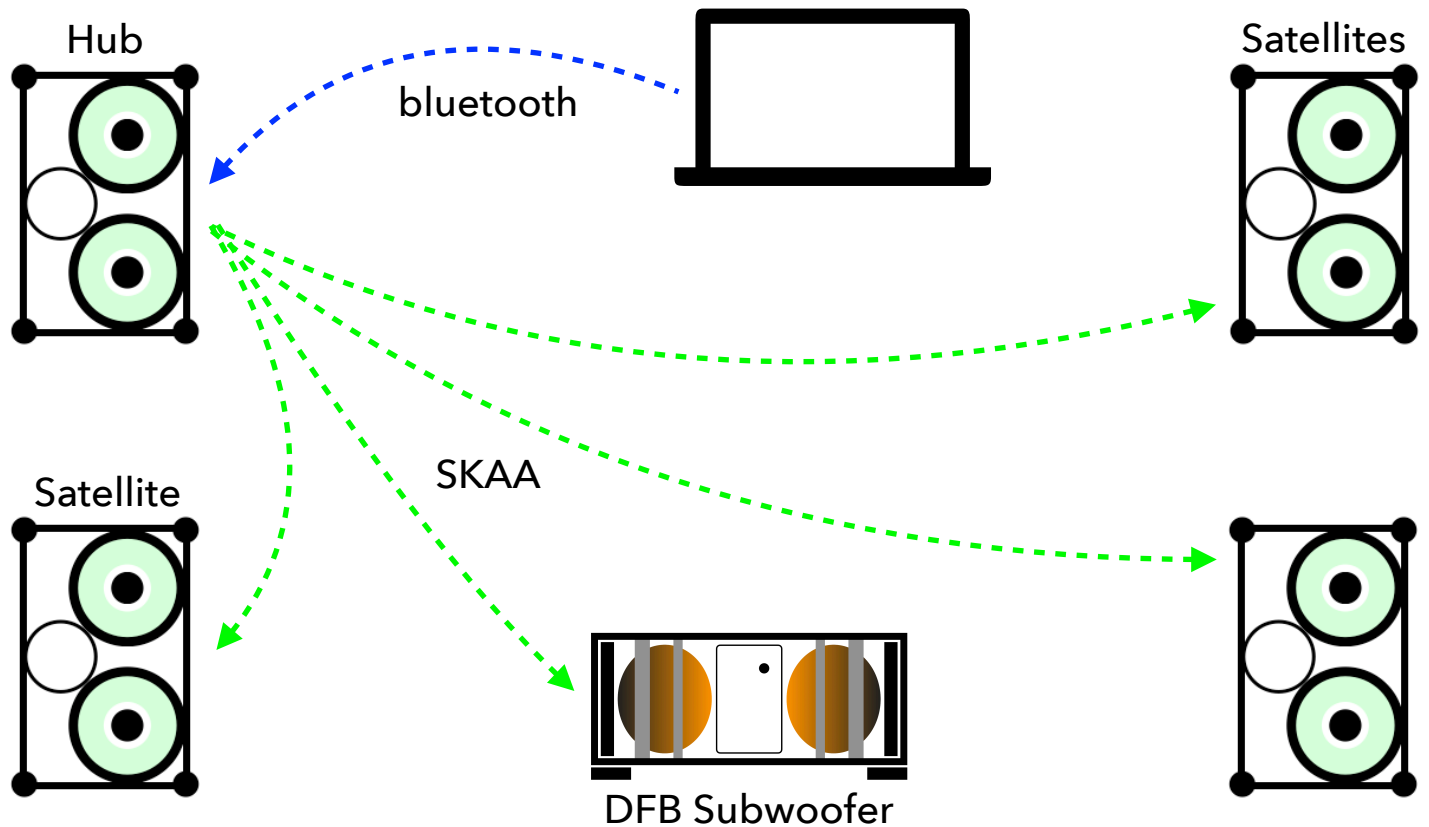

13

the ever-more-common deckless DJ

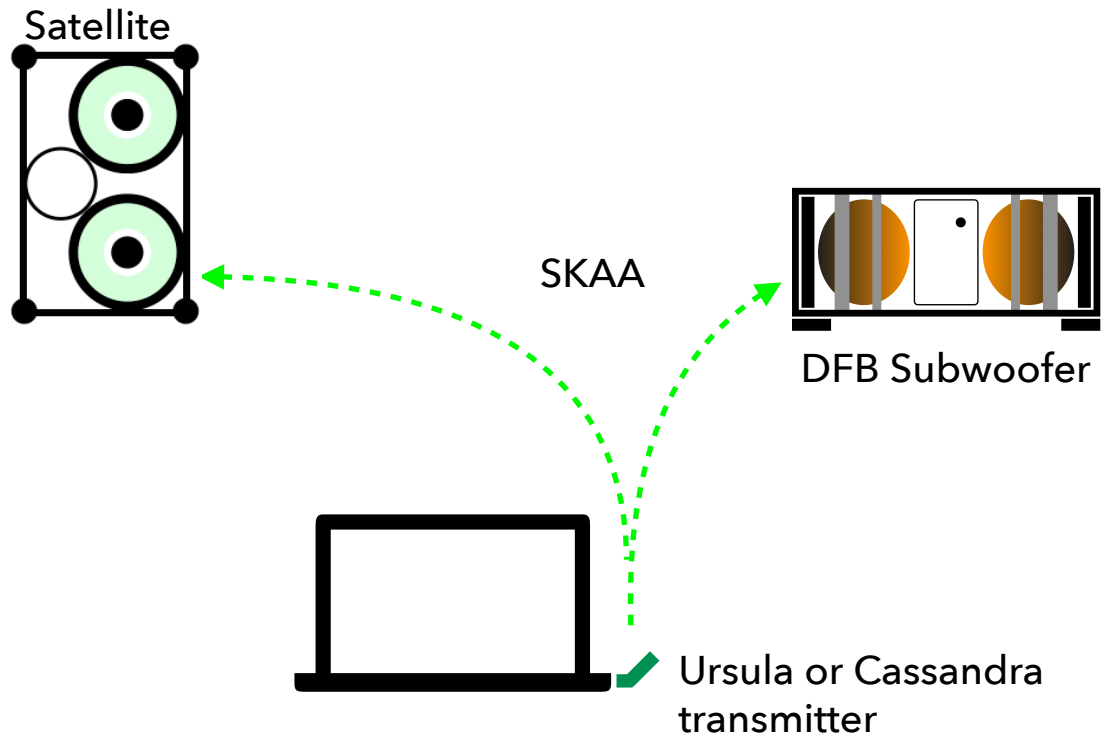

14

... and for a bigger room

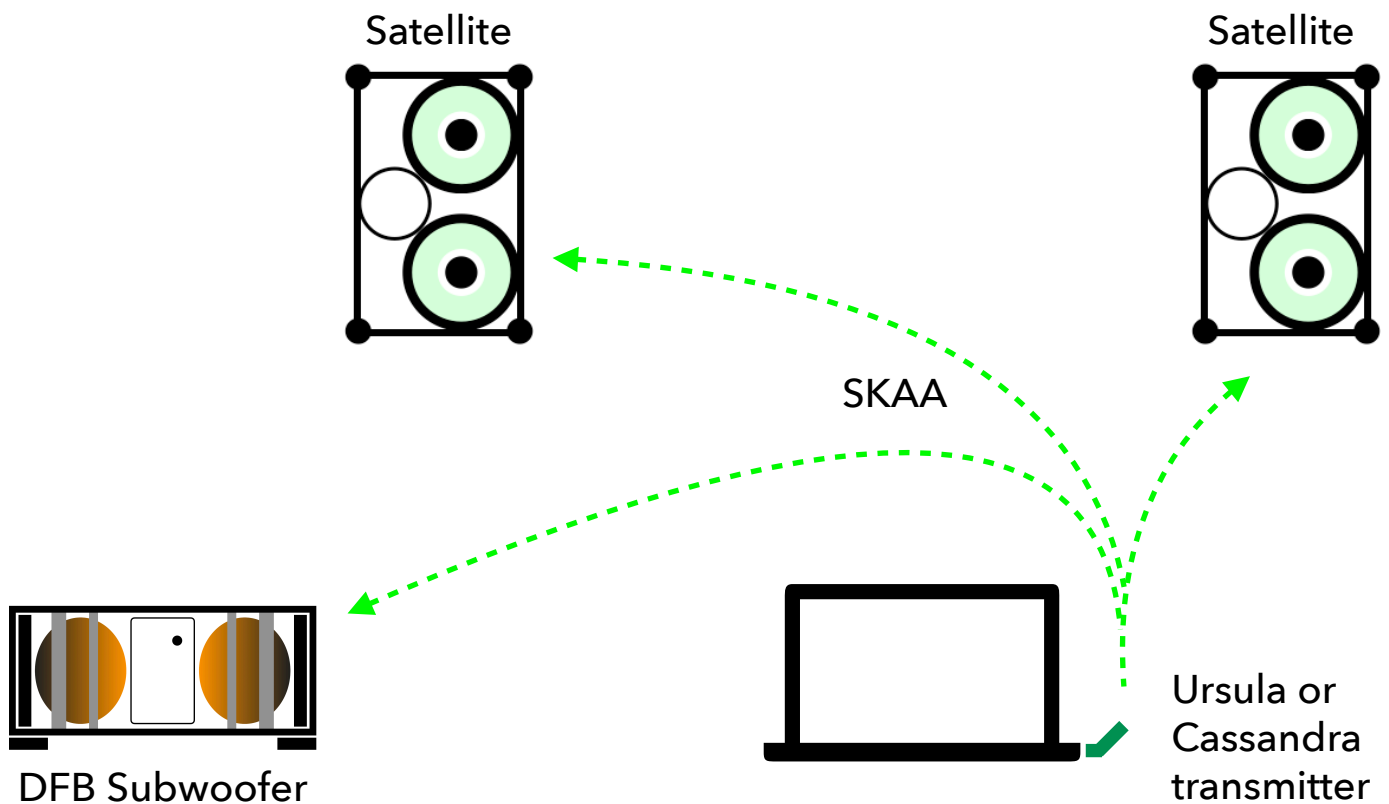

15

deckless DJ in a hall

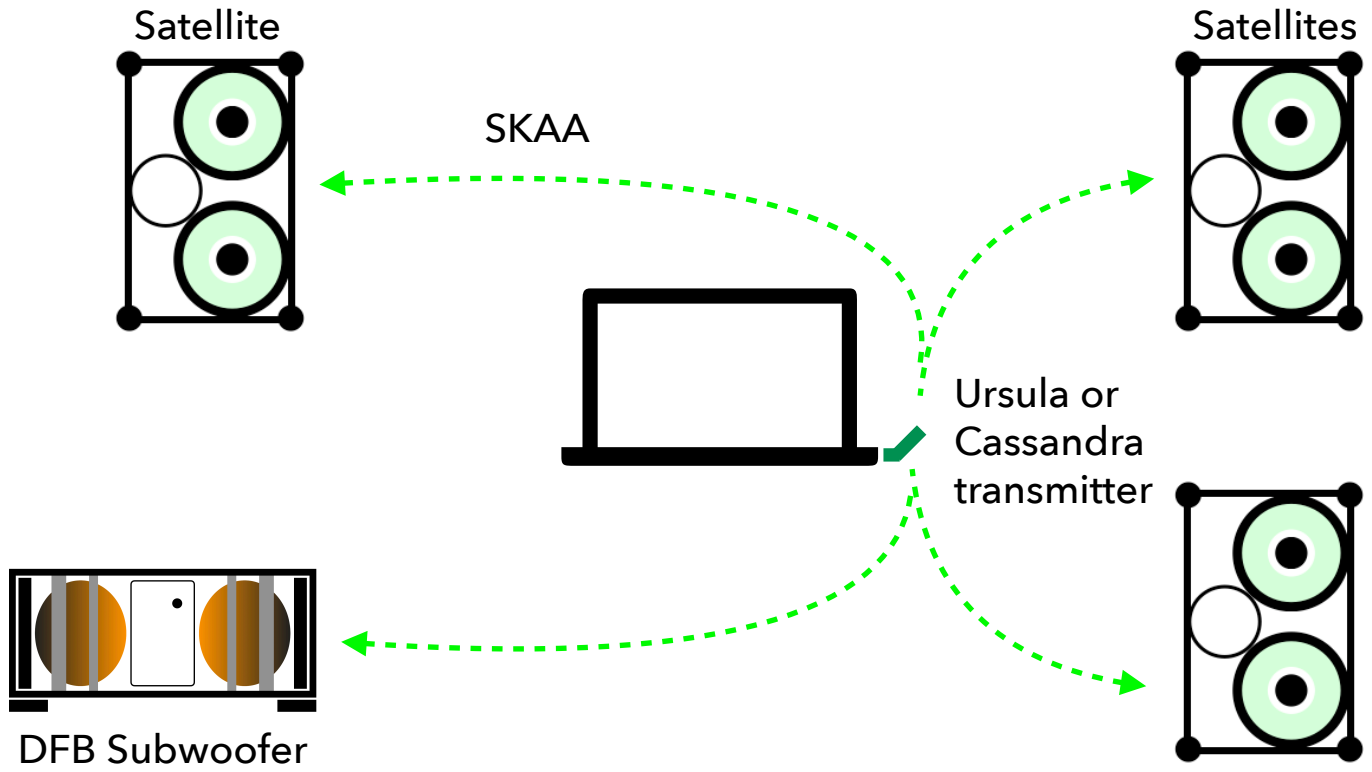

16

even better ... dope stereo towers

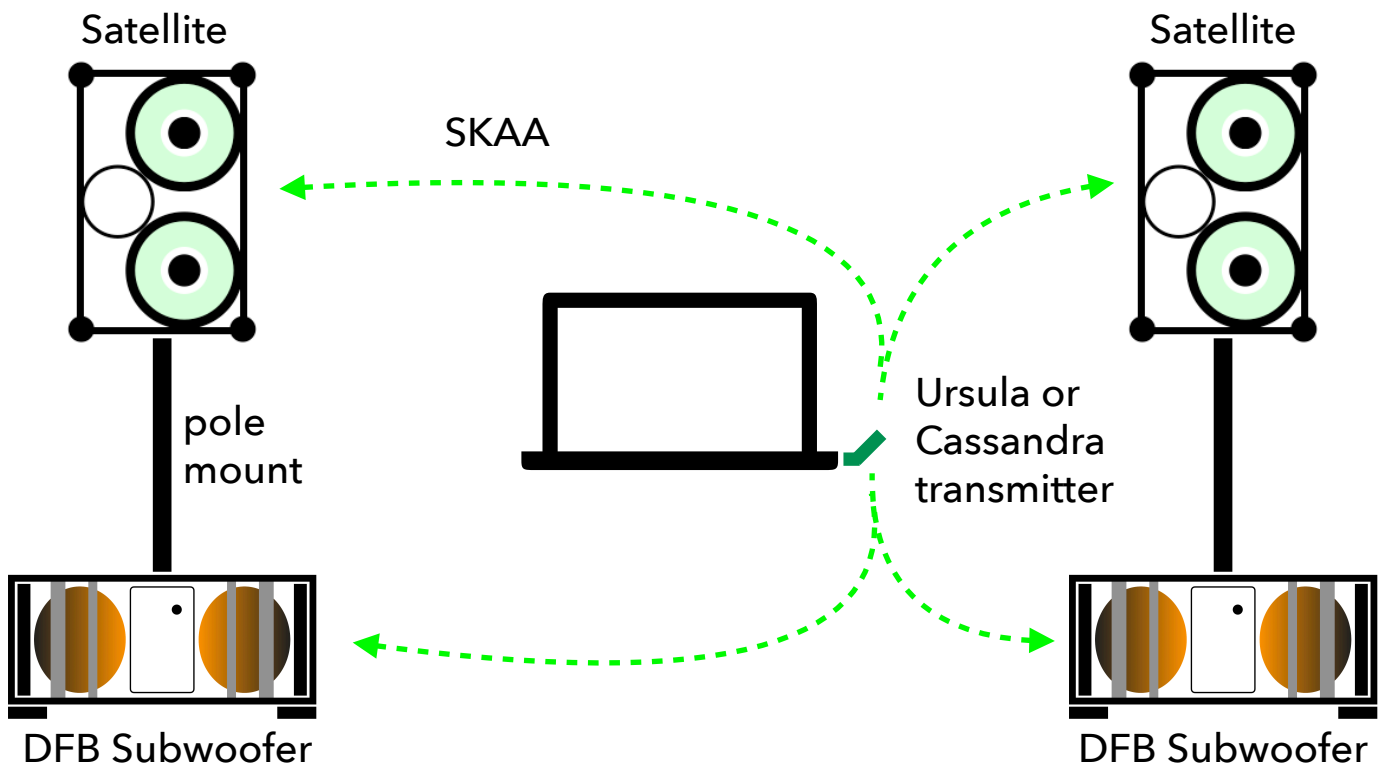

17

watch vids, social media, play games

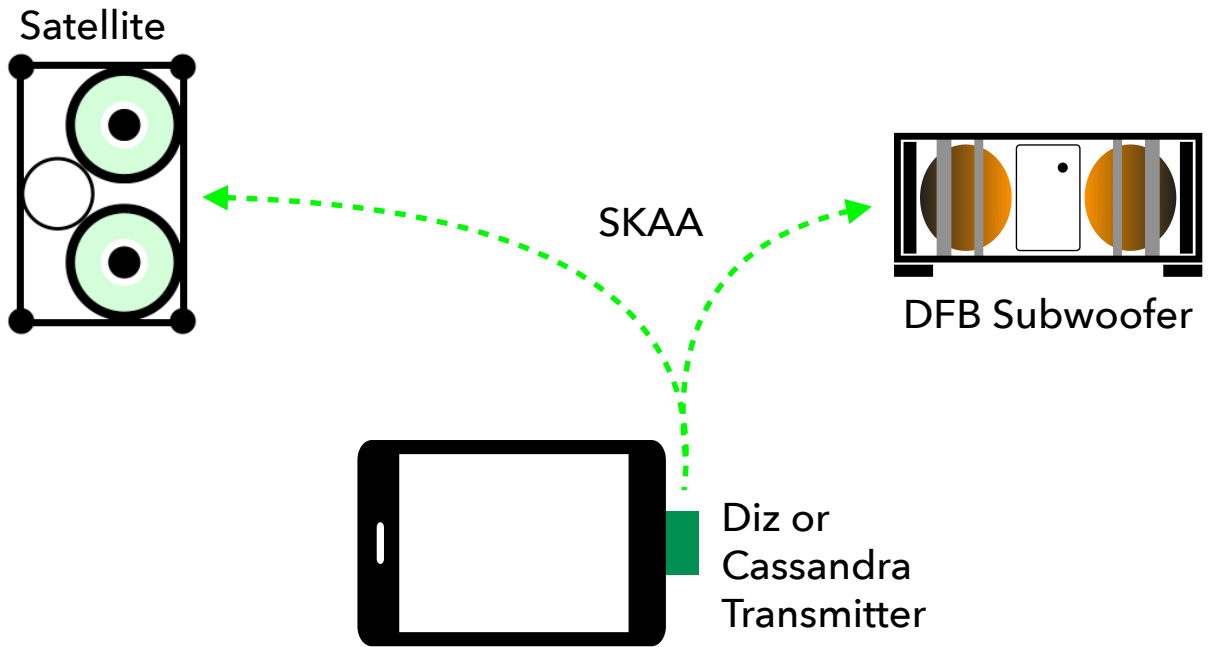

18

... let's play that game in stereo, shall we?

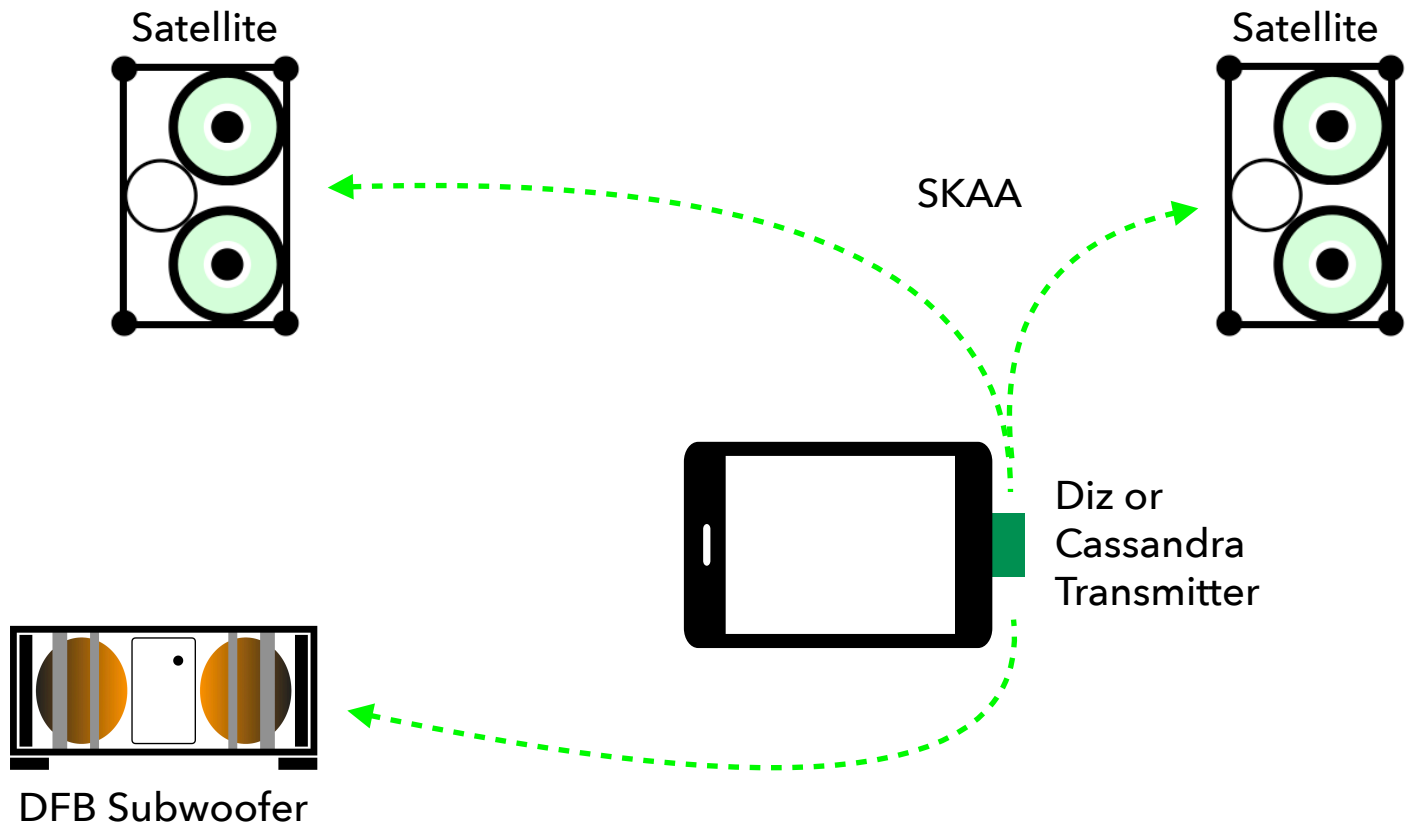

19

watch vids, play games on TV

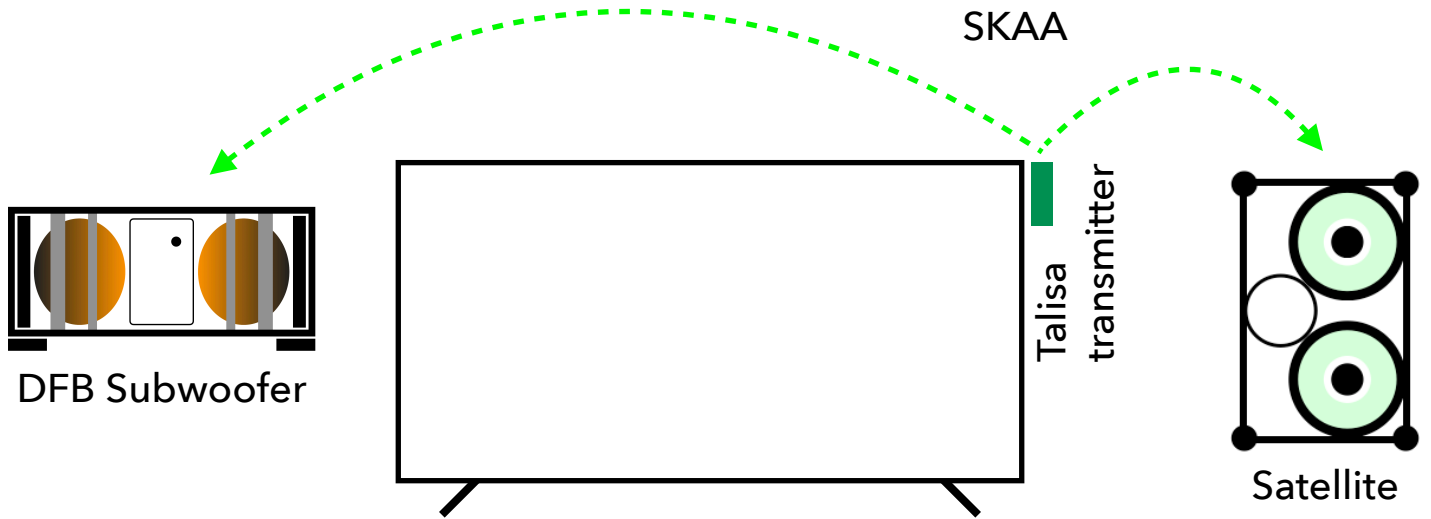

20

... stereo TV with mondo bass

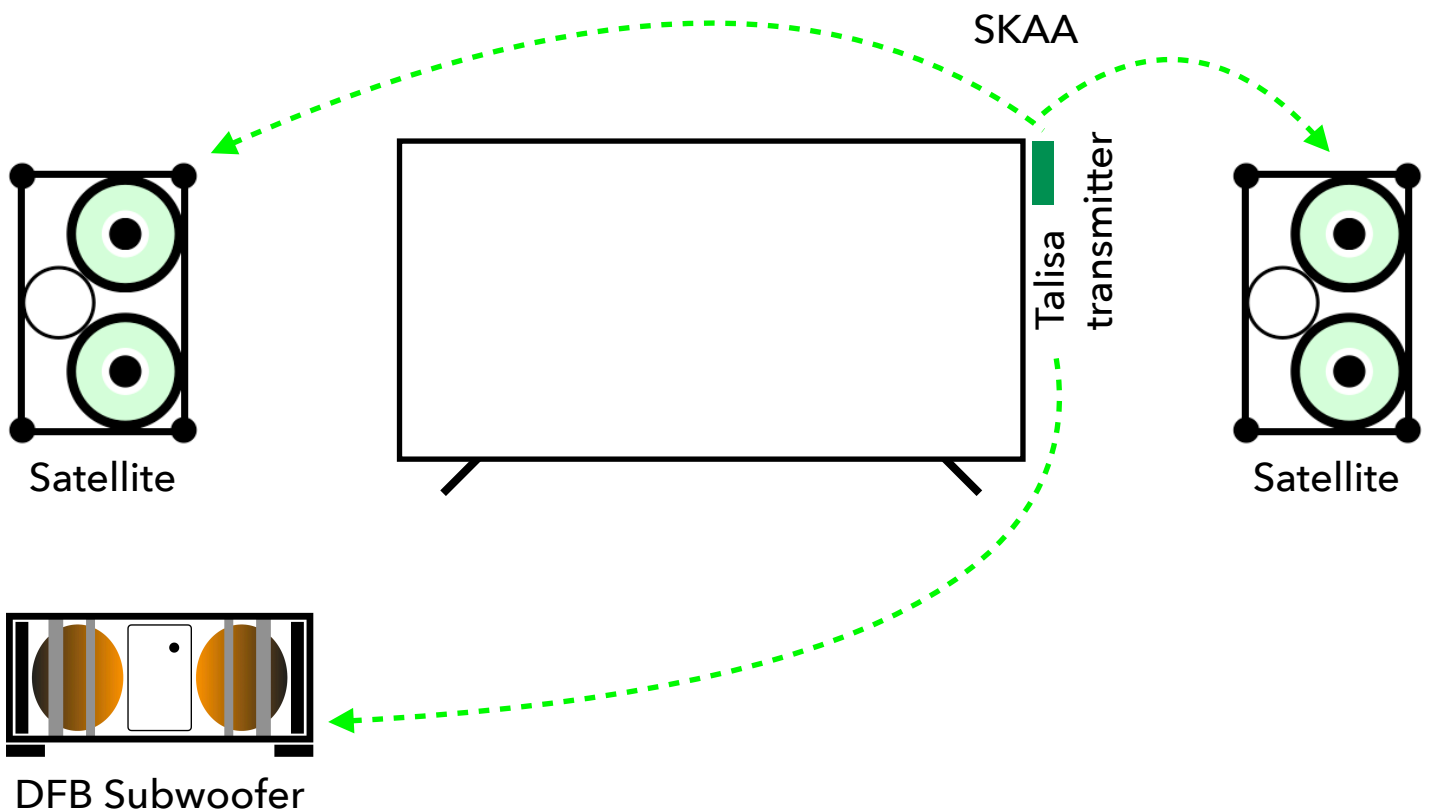

21

play live

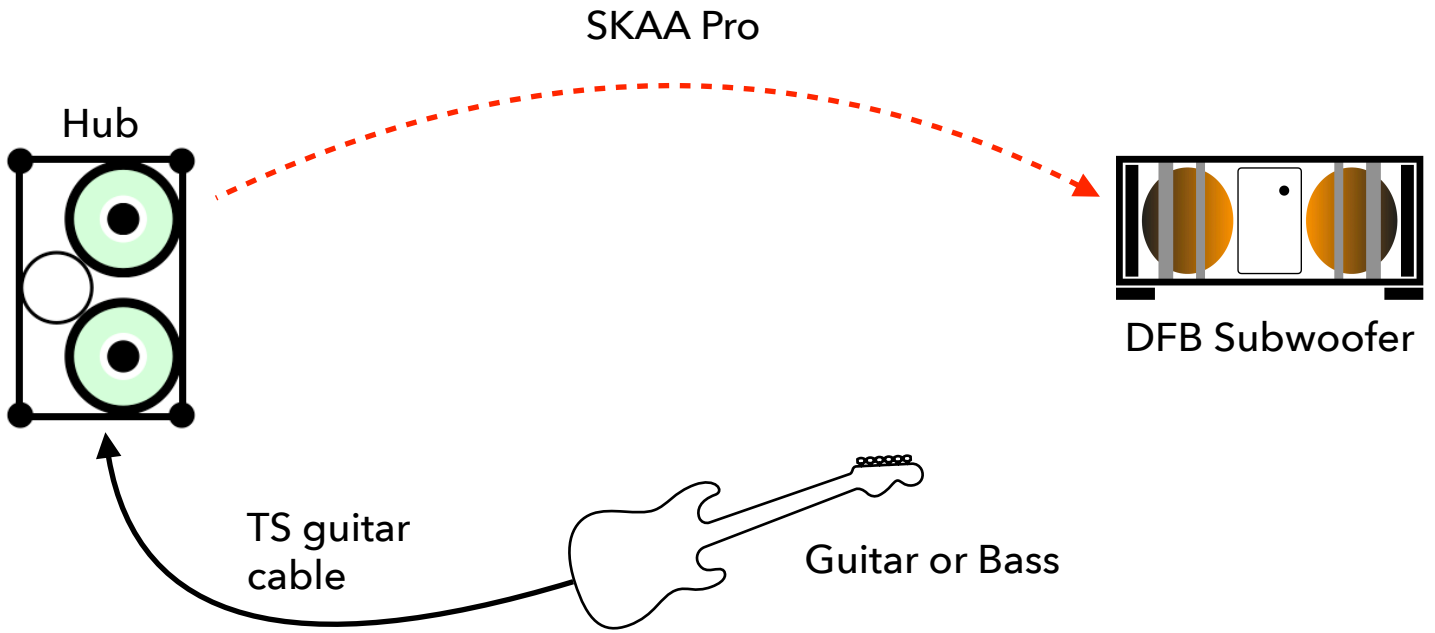

22

... add a backing track

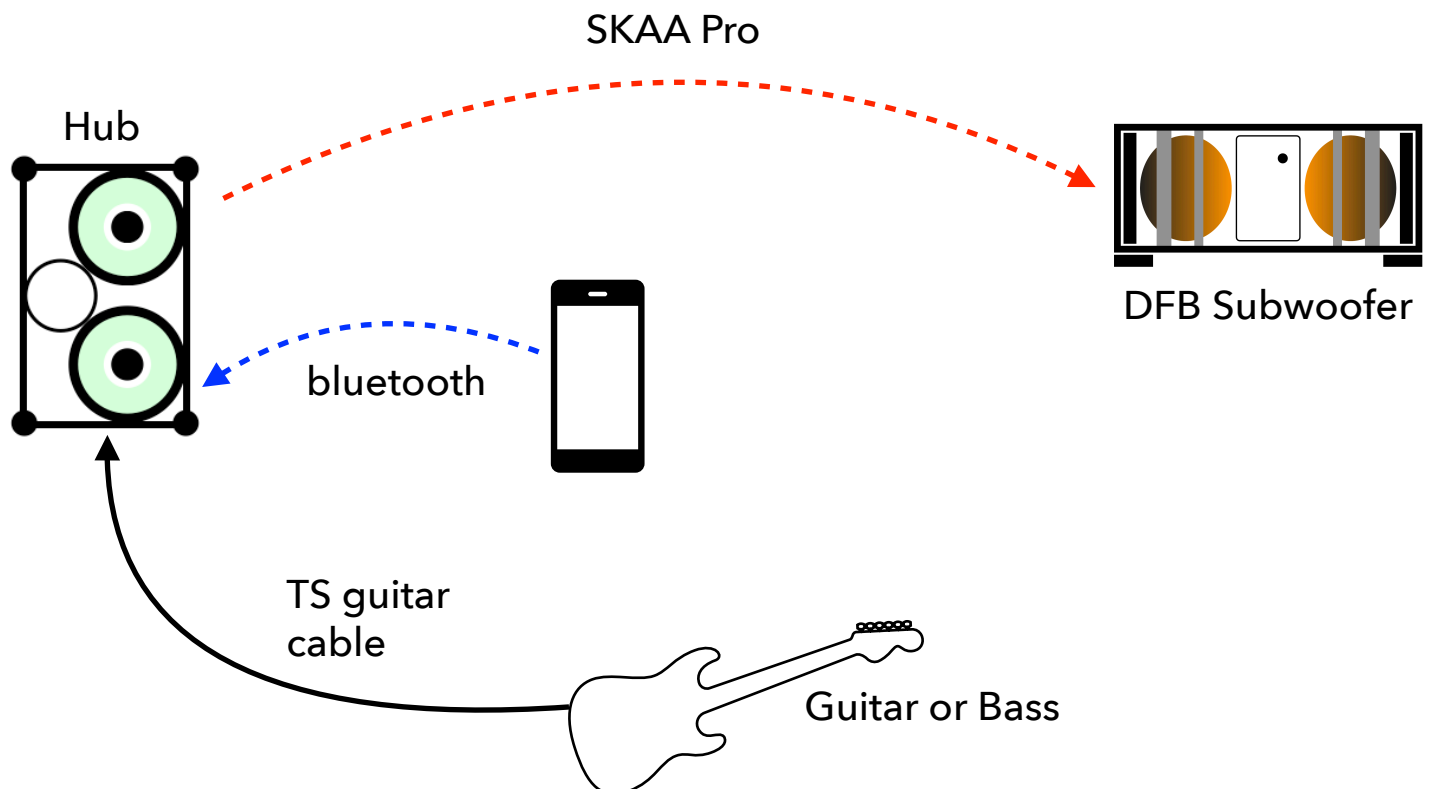

23

play completely wireless

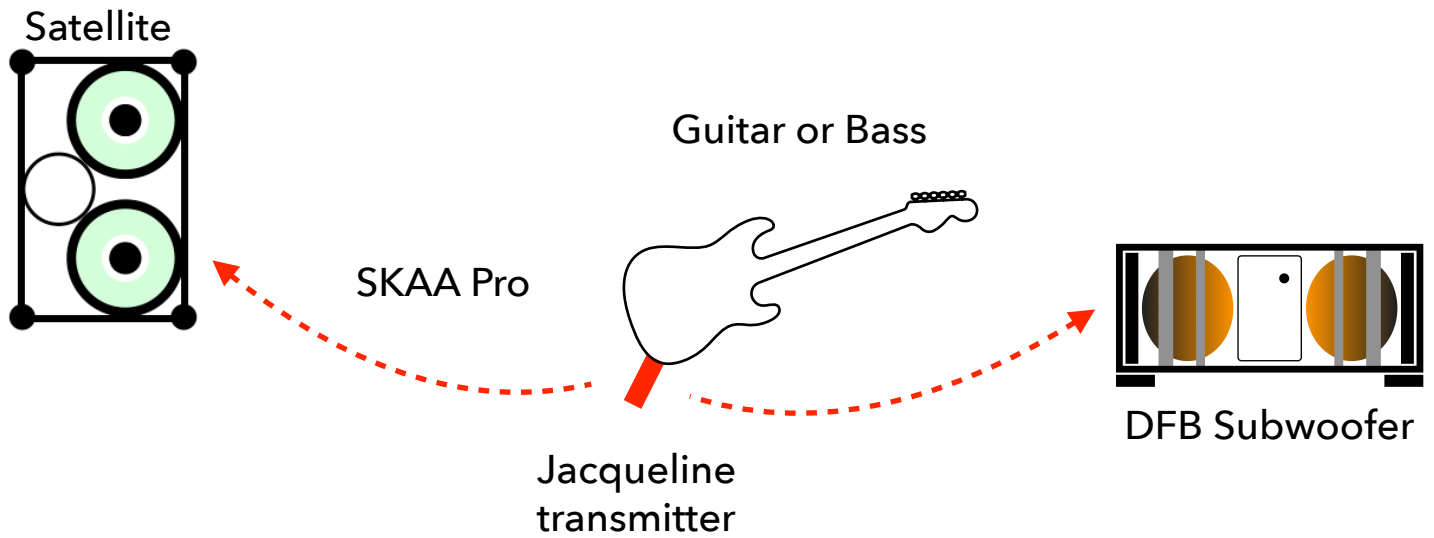

24

... with backing track I

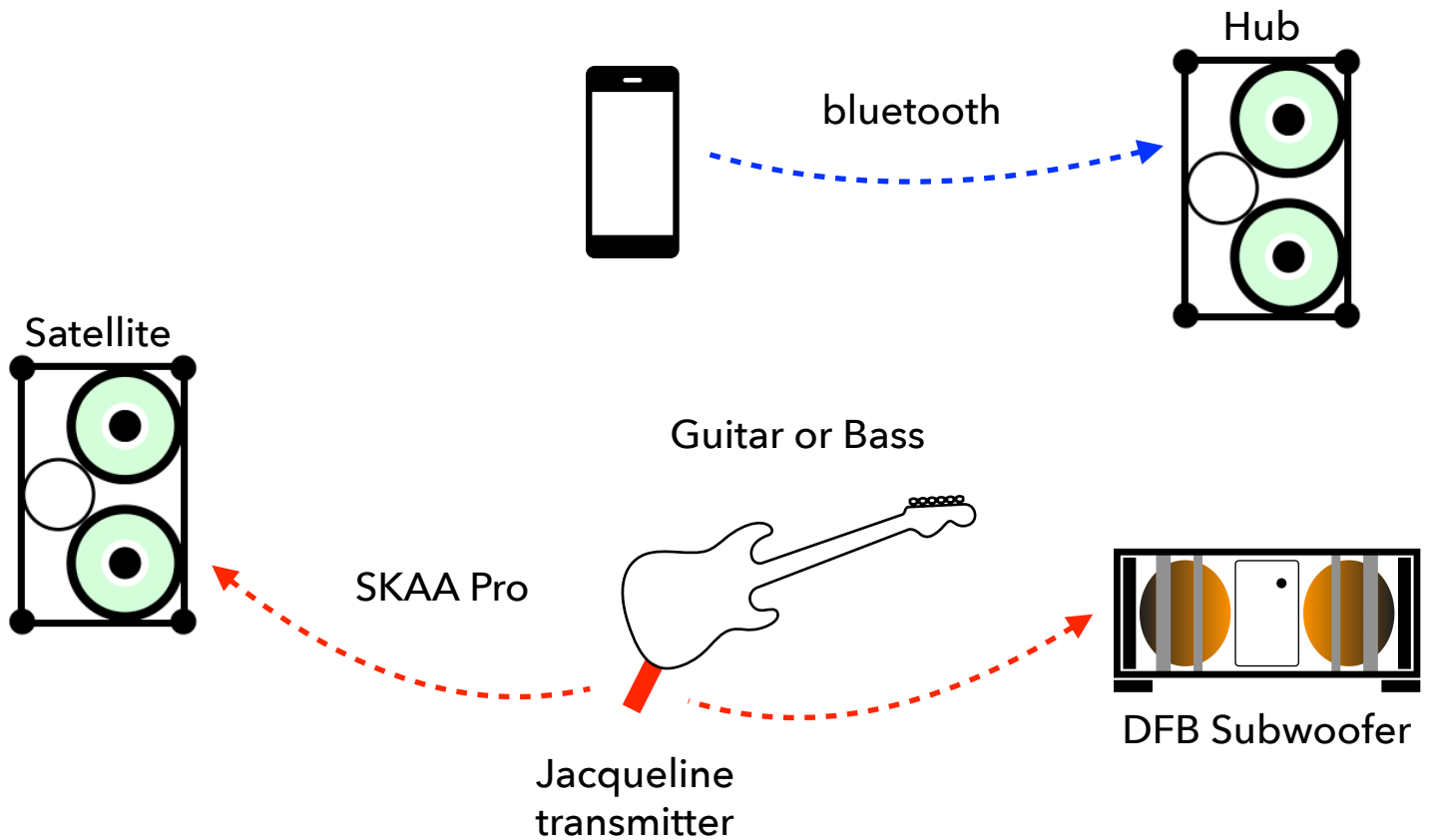

25

... with backing track II

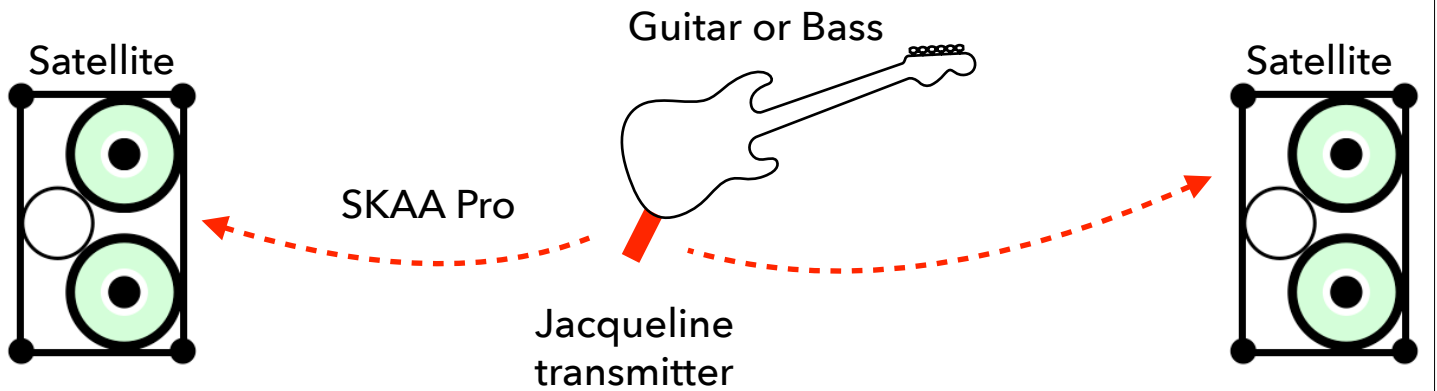
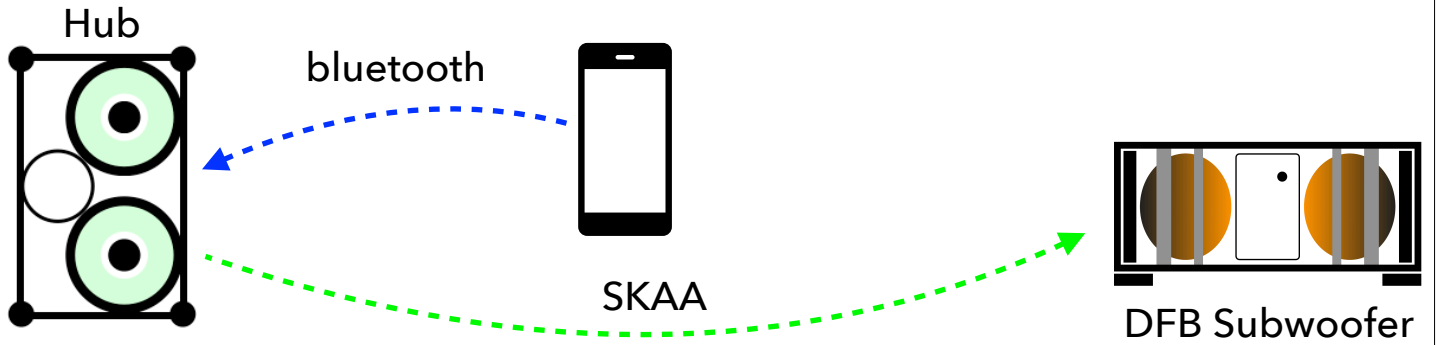

26

... with backing track III

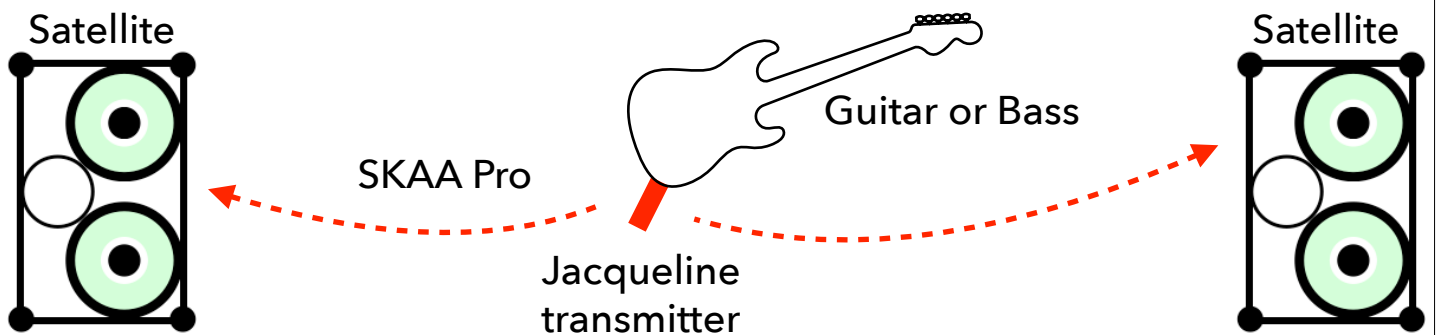
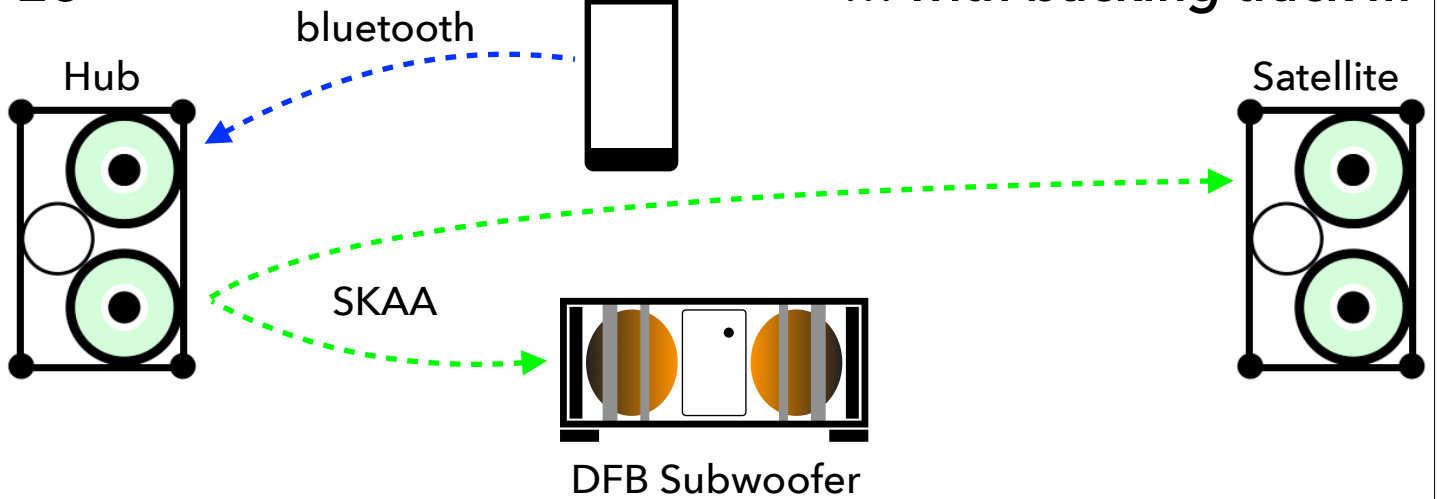

27

play with distortion & FX

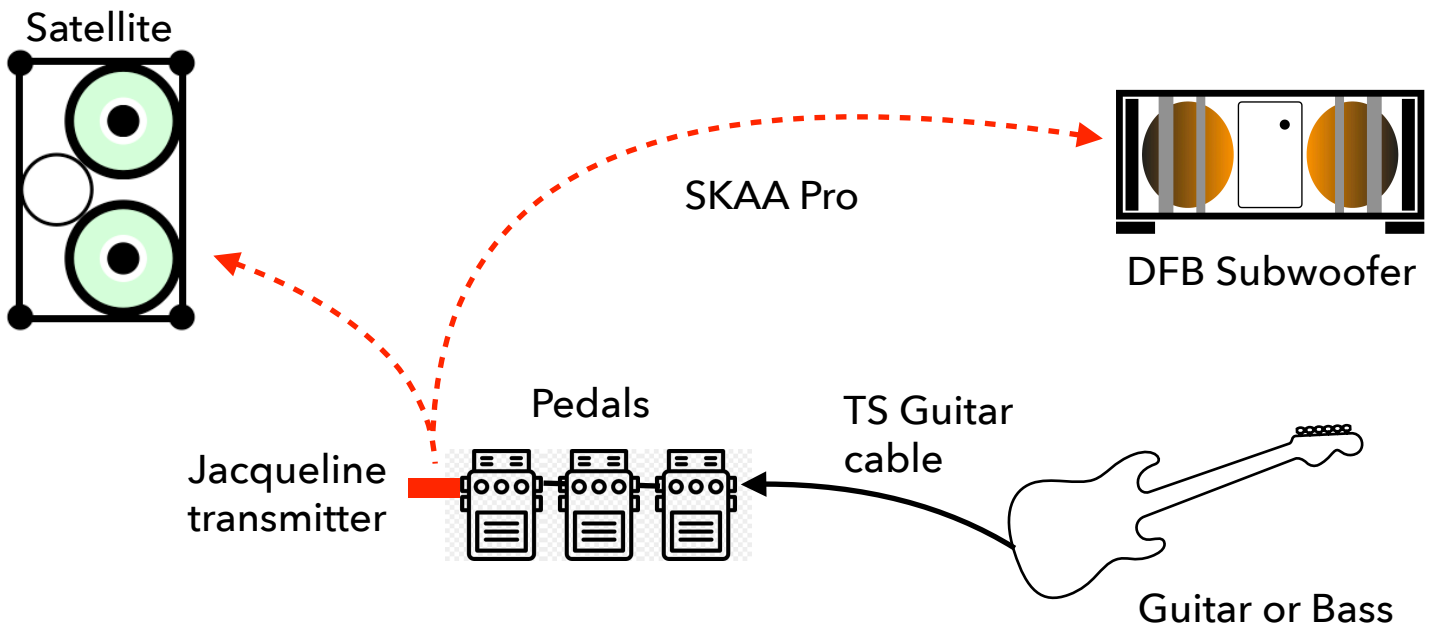

28

... or use a SKAA guitar amp

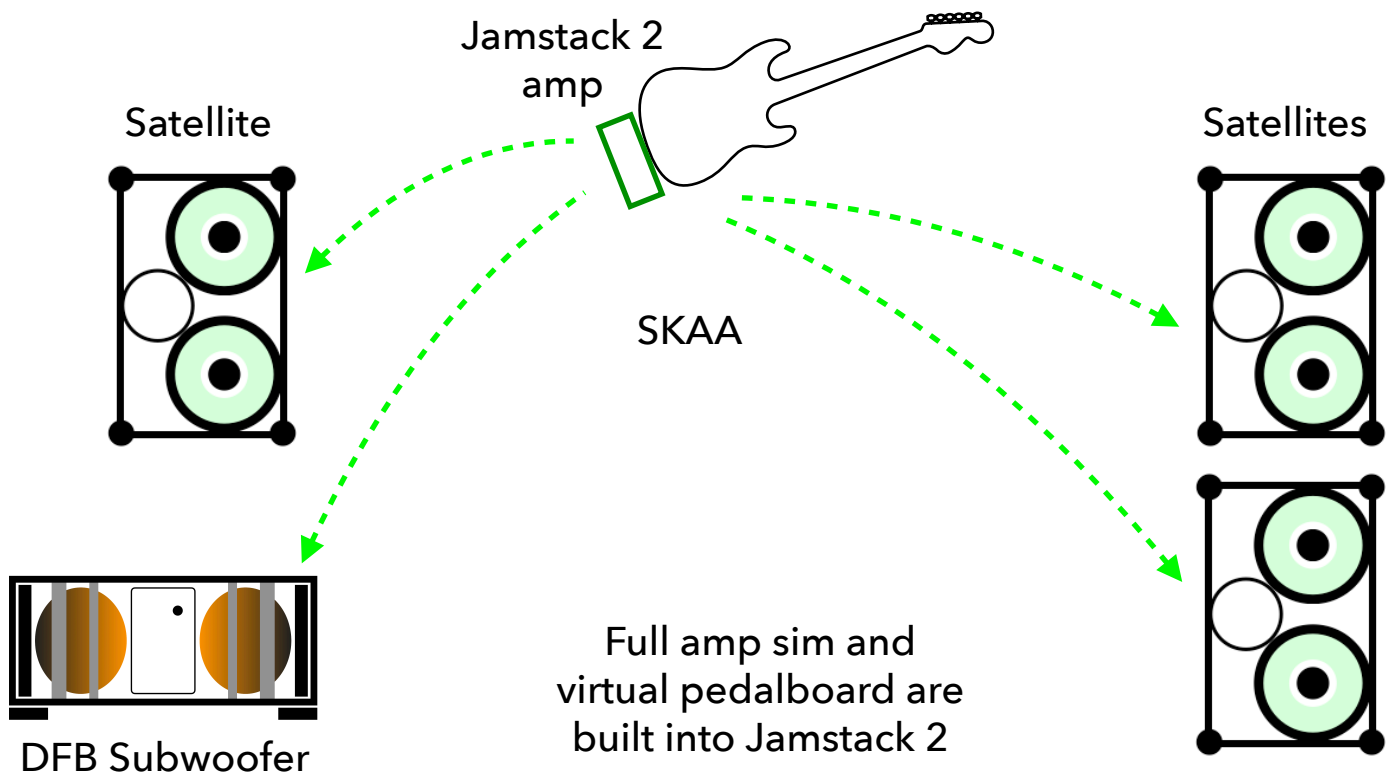

29

hybrid jam

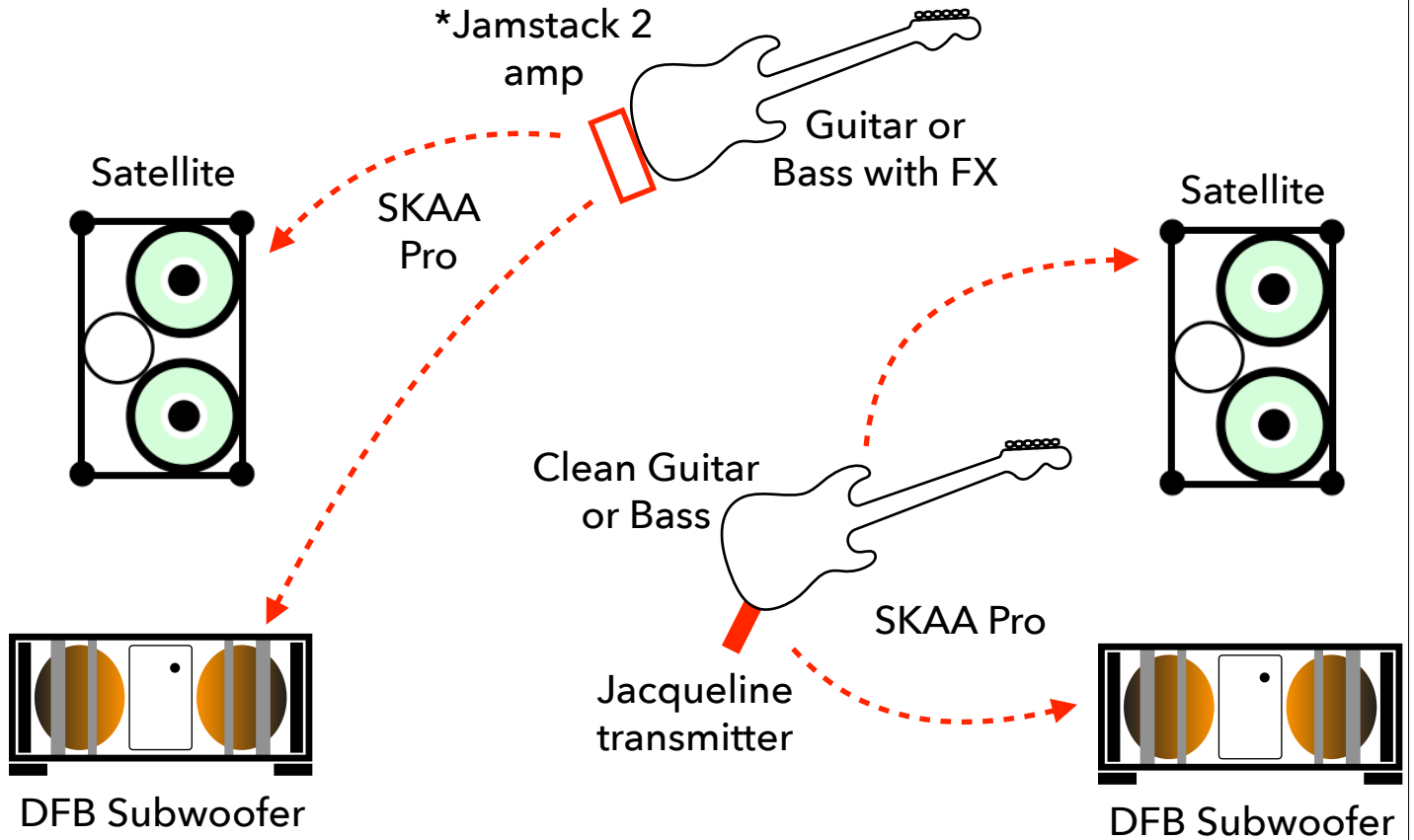

30

Jamstack 2 pro jam with backing track

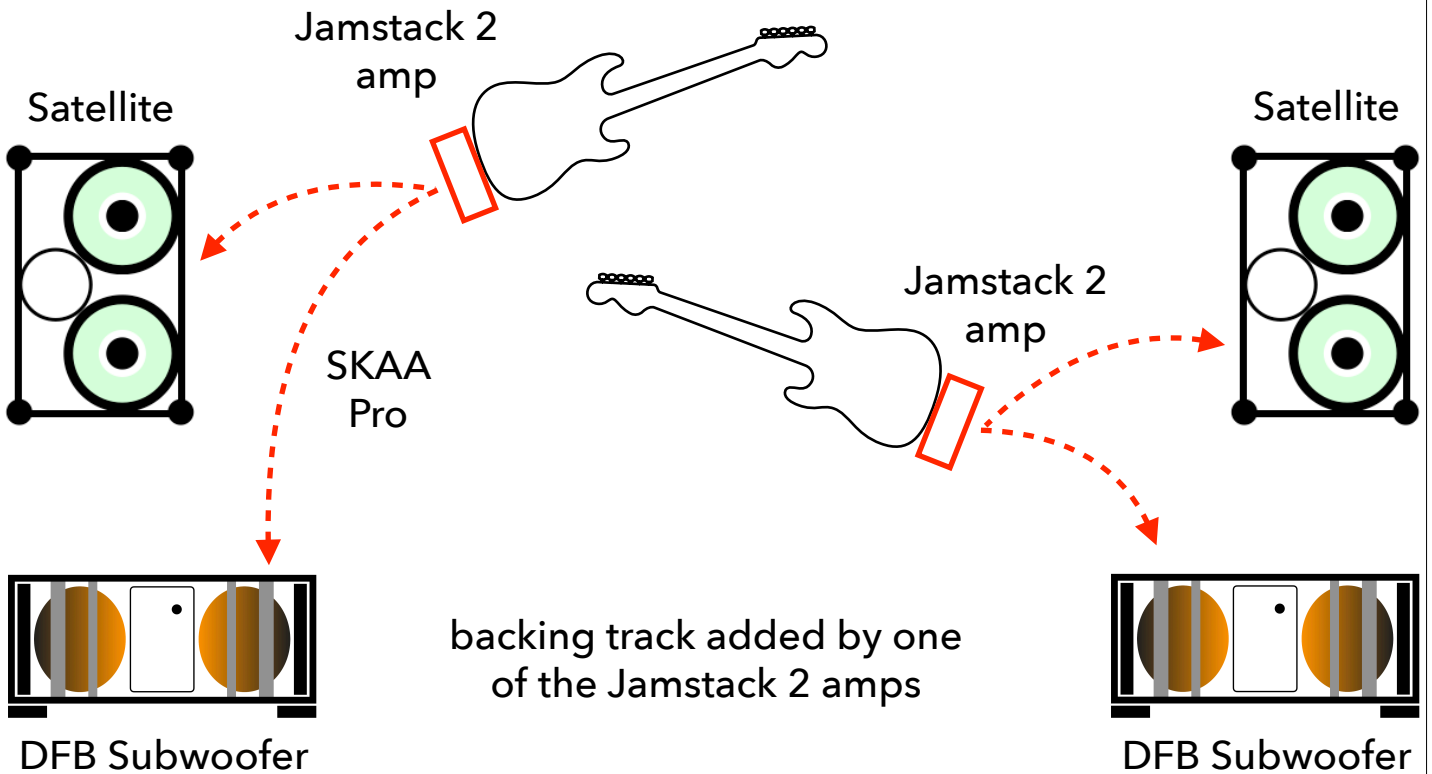

31

recording with Cerwin Vega Studio Monitors

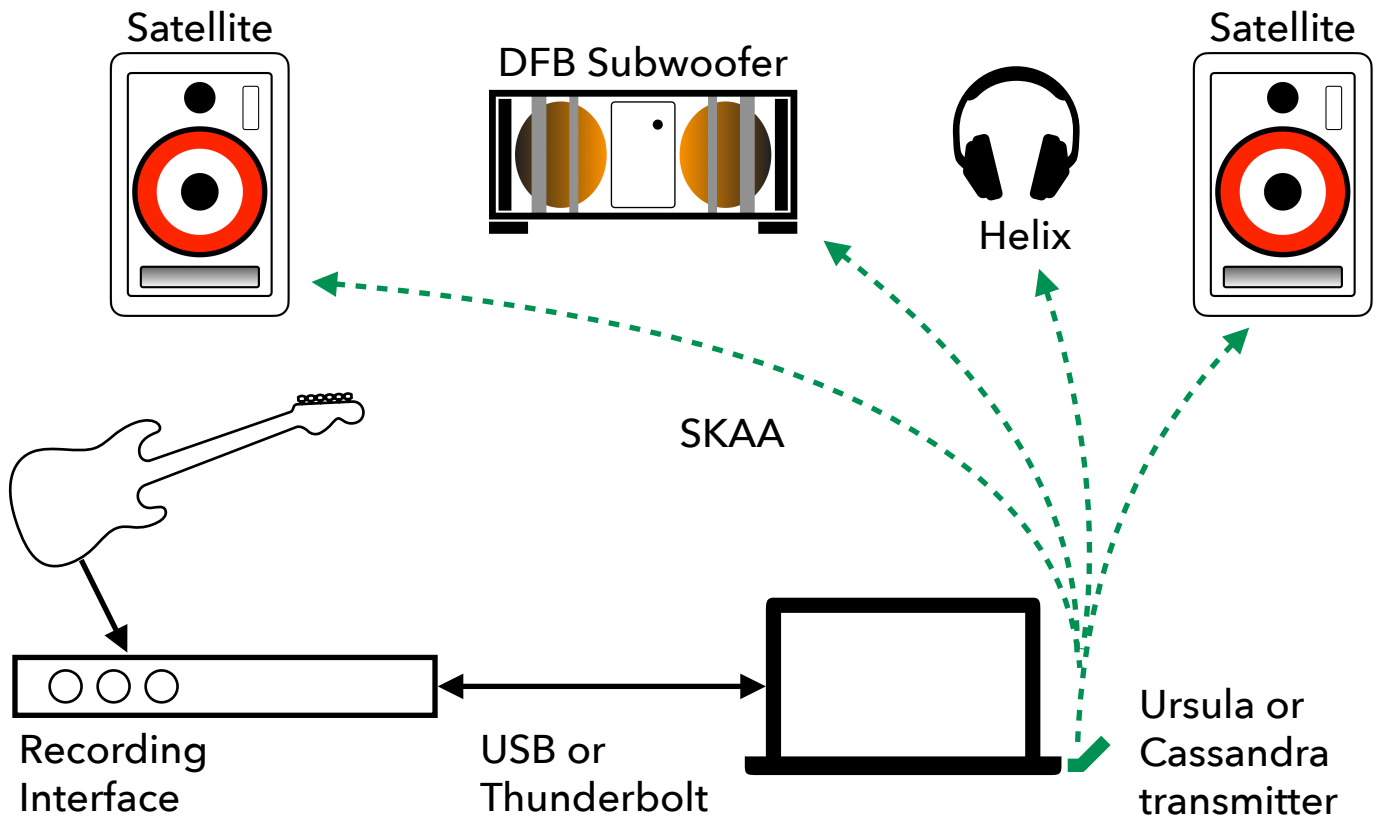

32

... or drop latency like so

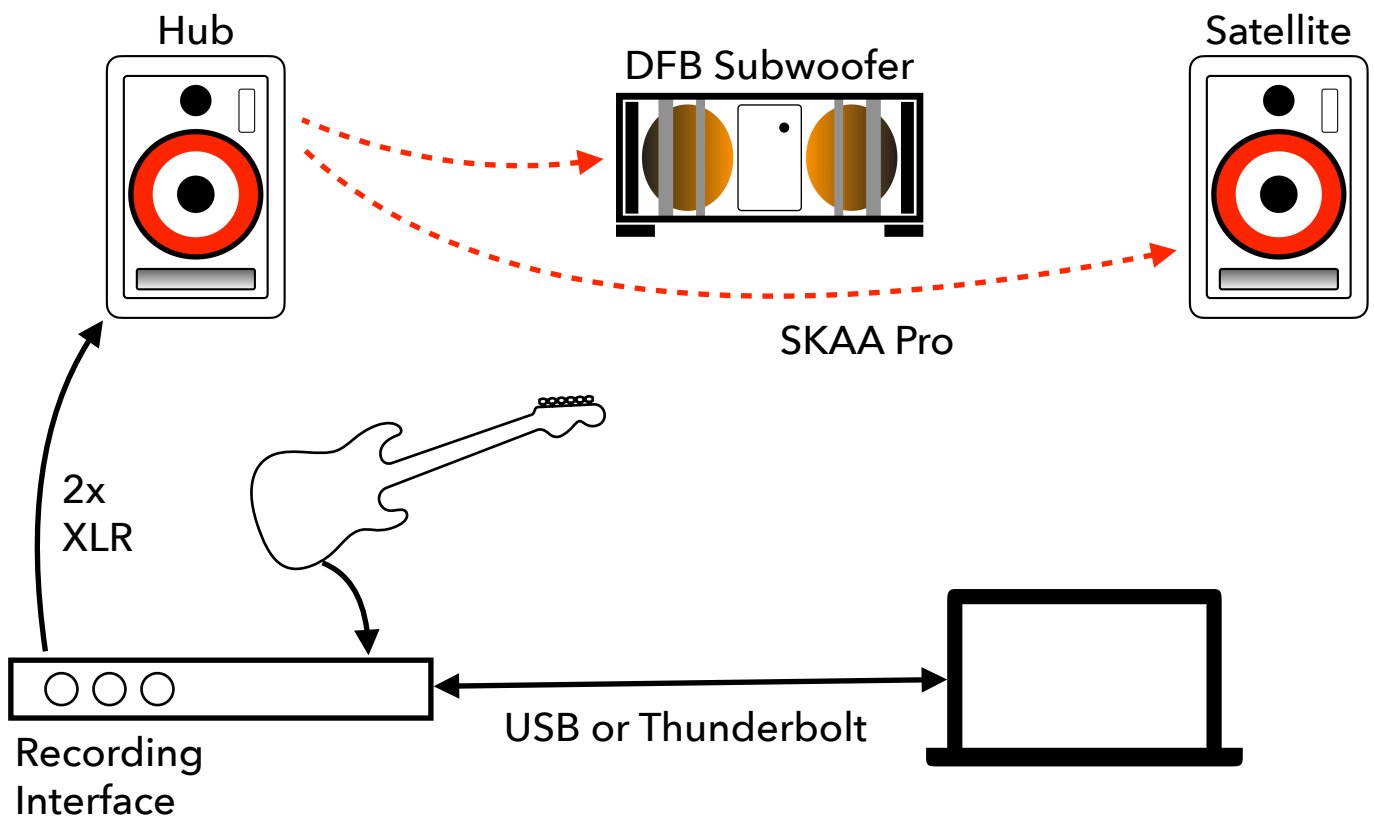

33 ... or go with fully wireless speakers & headphones

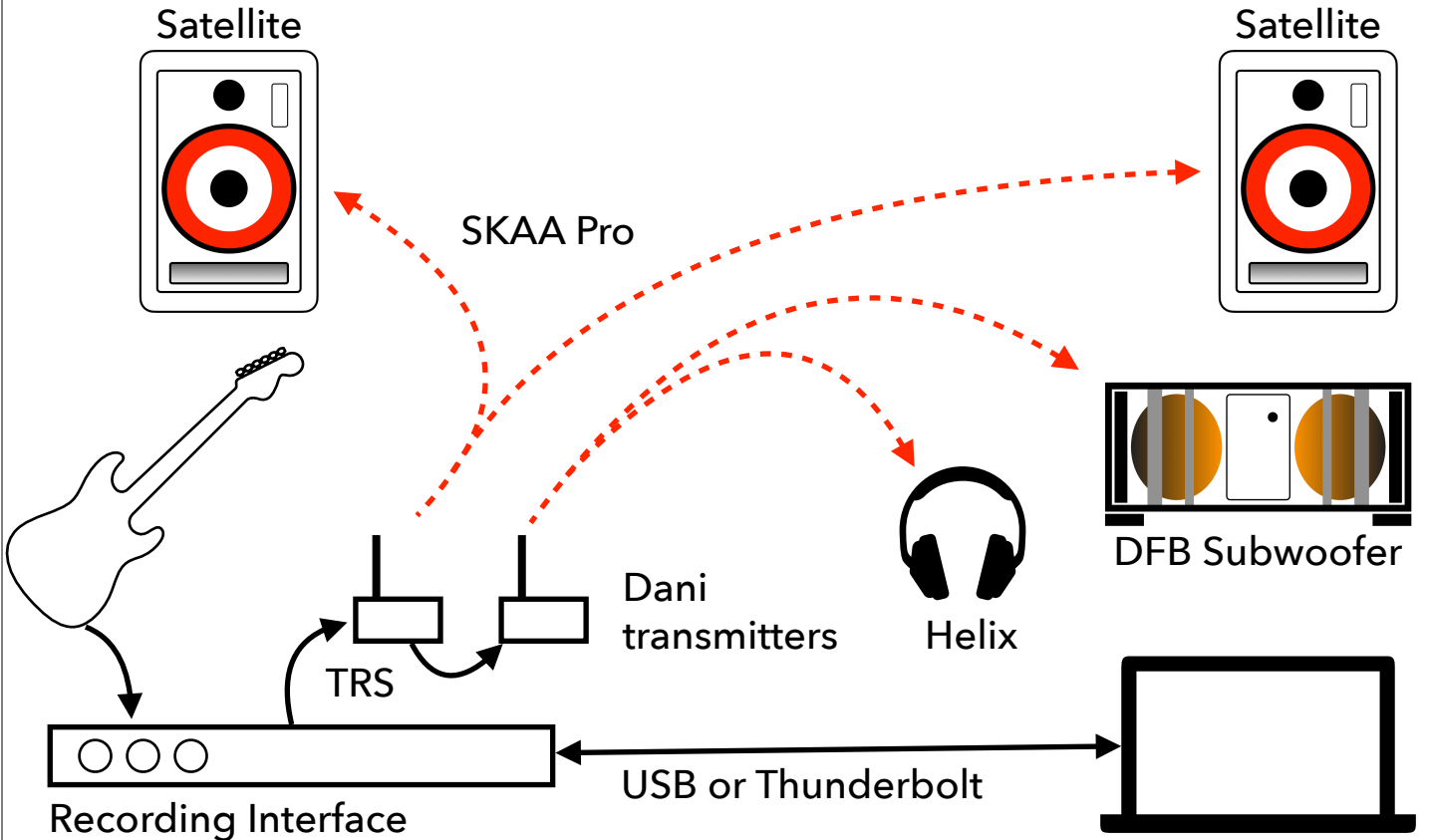

34 pro setup: subs fed by separate DAW outputs

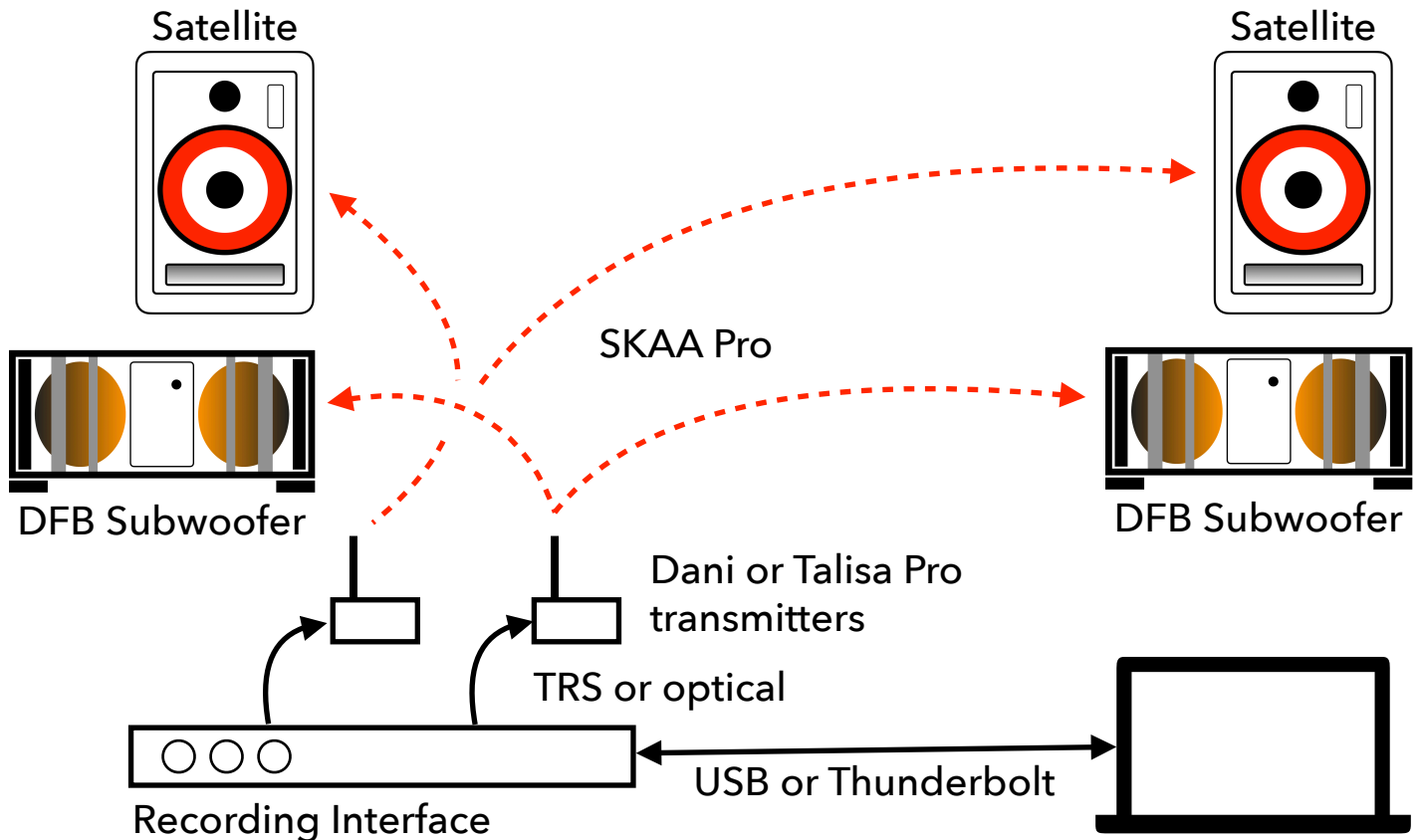

35

basic PA for live performance

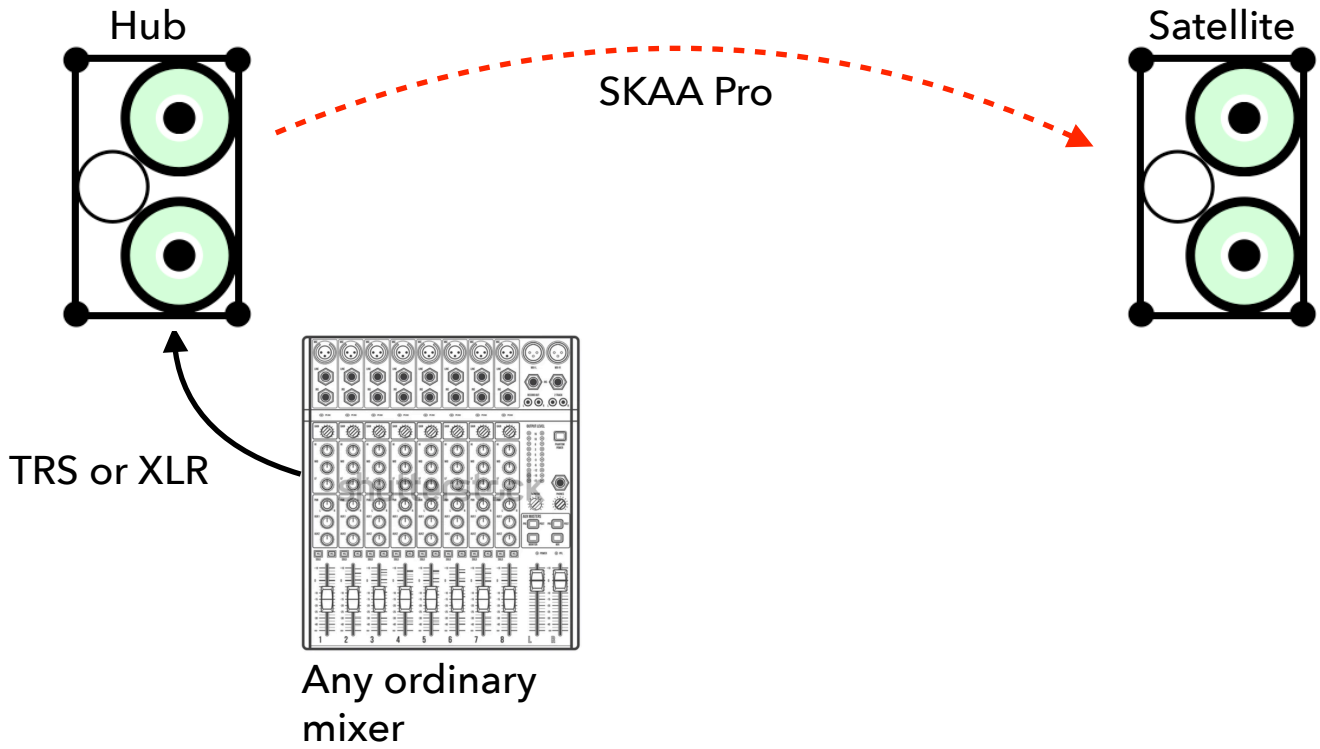

36

... add a sub

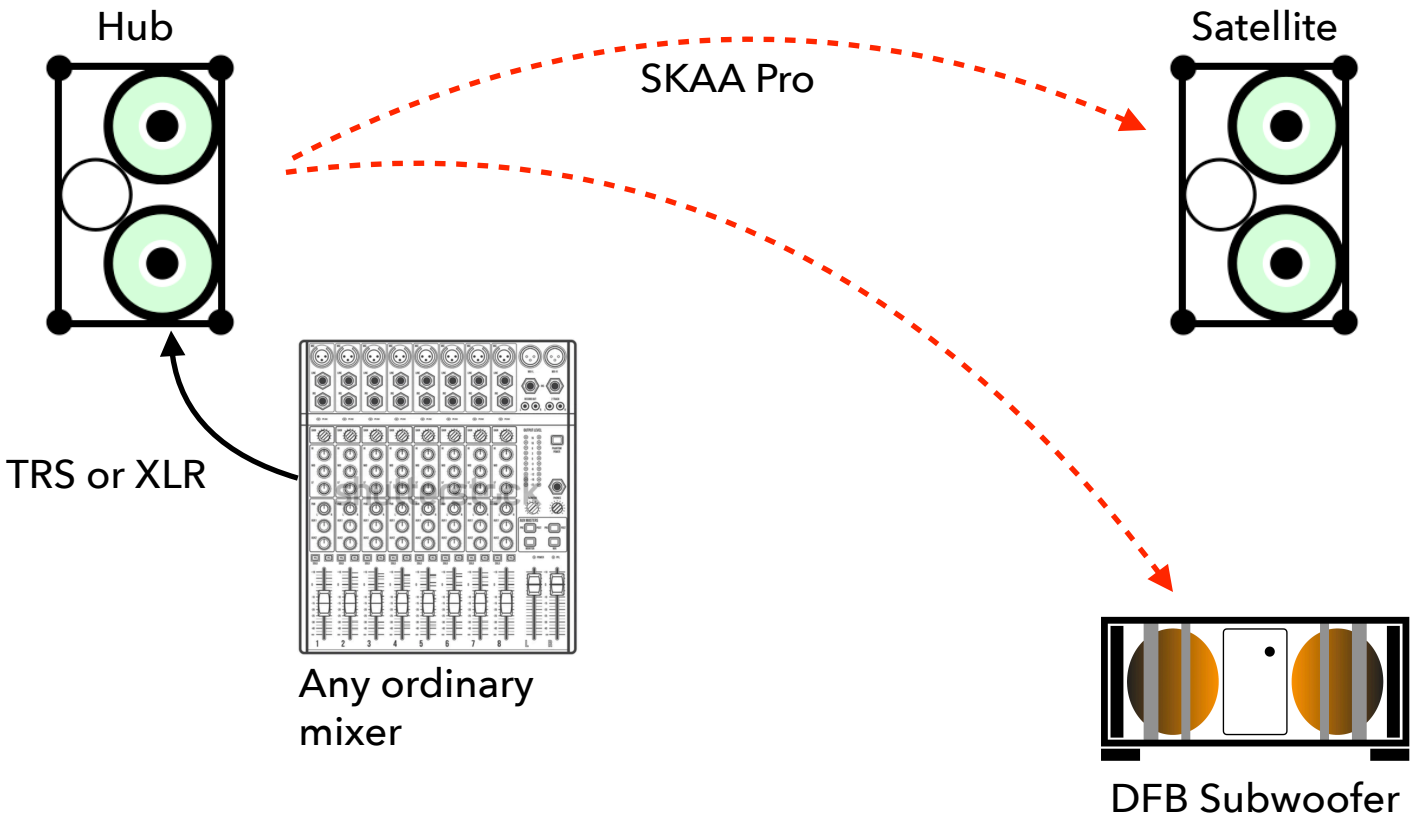

37

... 4 speaker PA with headphones

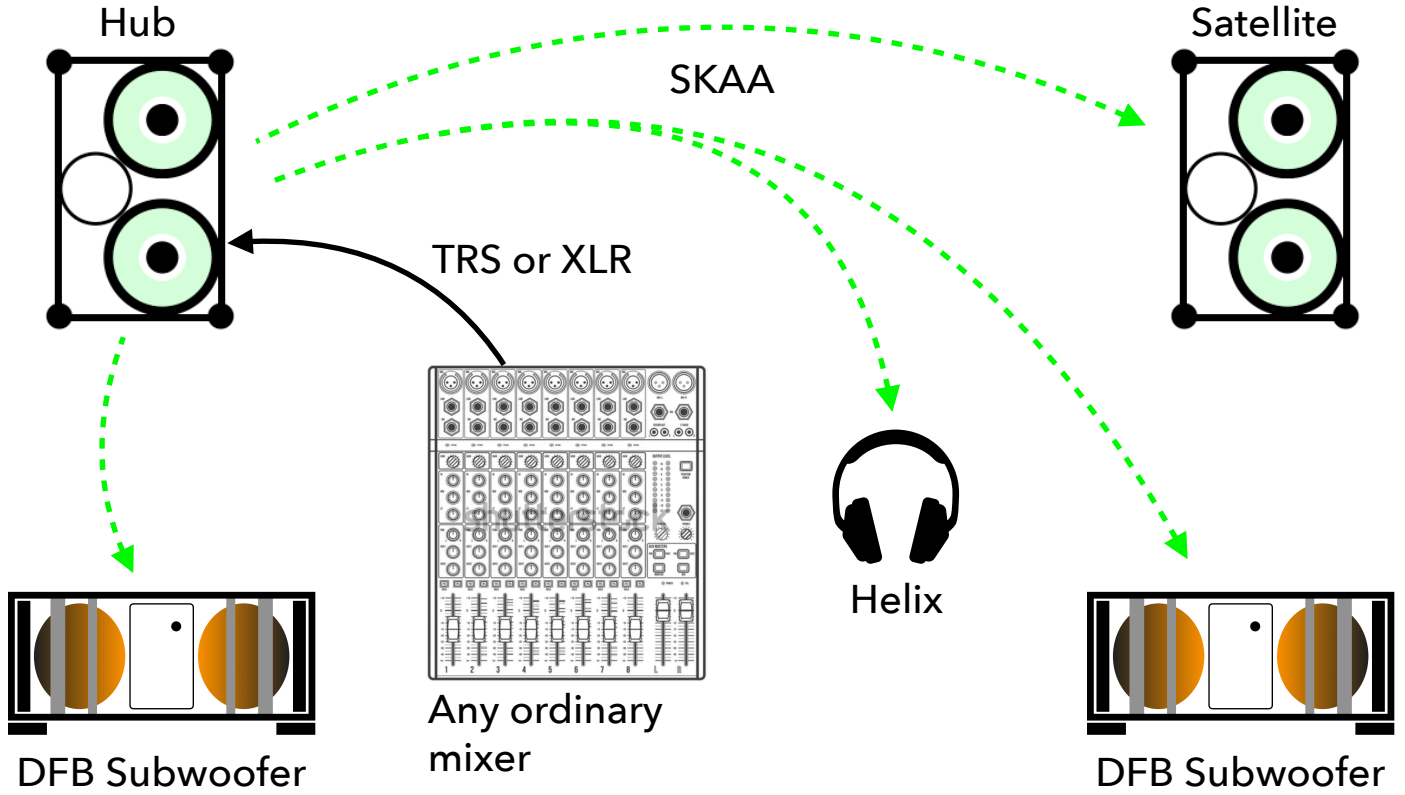

38

... or 5 speakers for better coverage

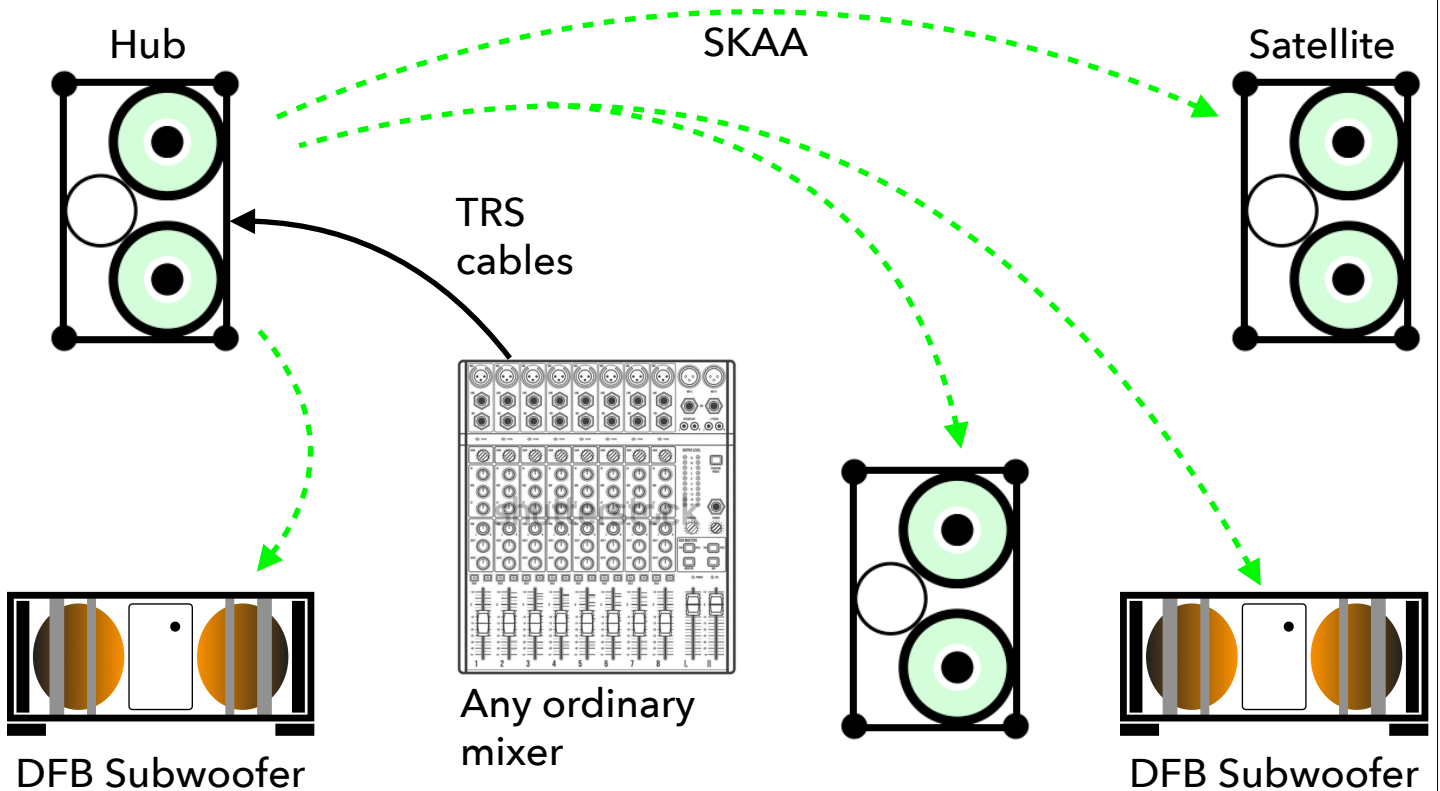

39

fully-wireless PA with Cerwin Vega SKAA mixer

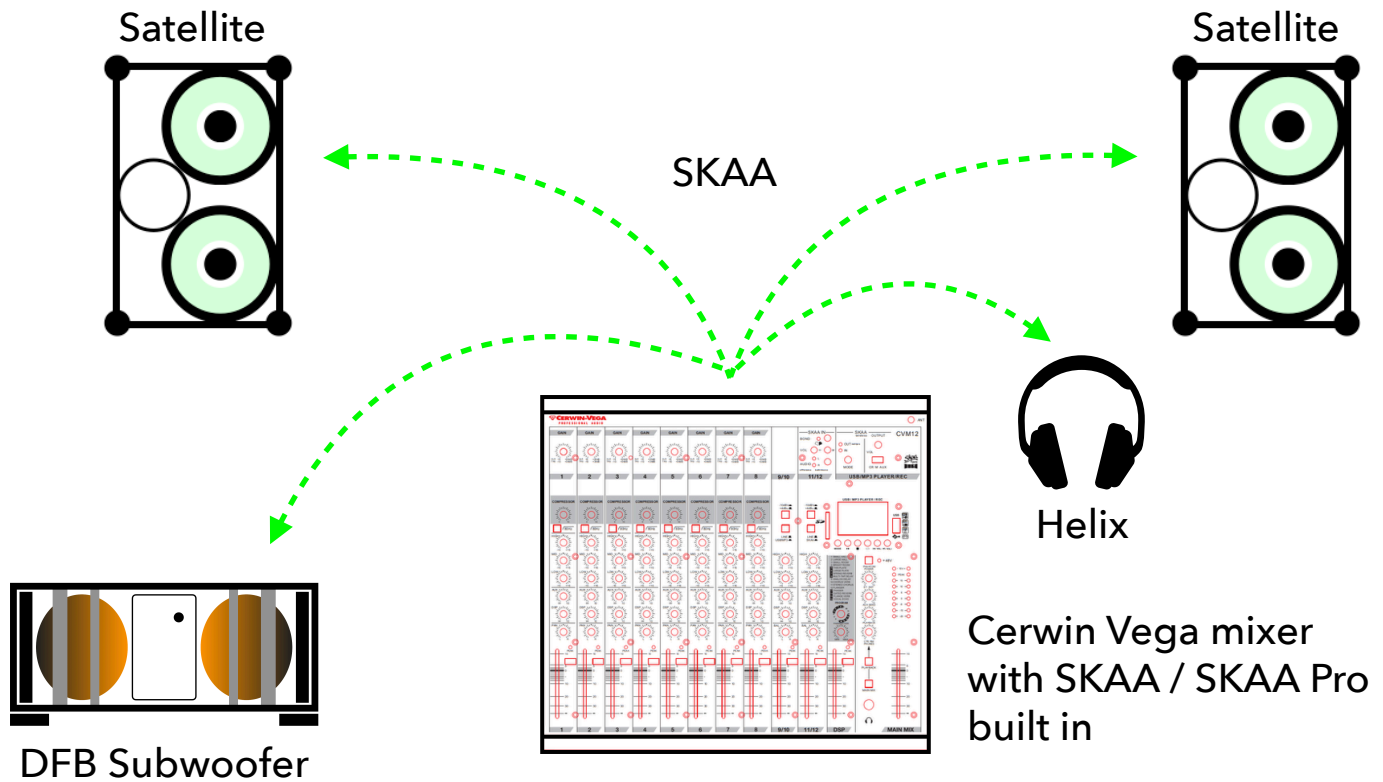

40

... or create a massive front end

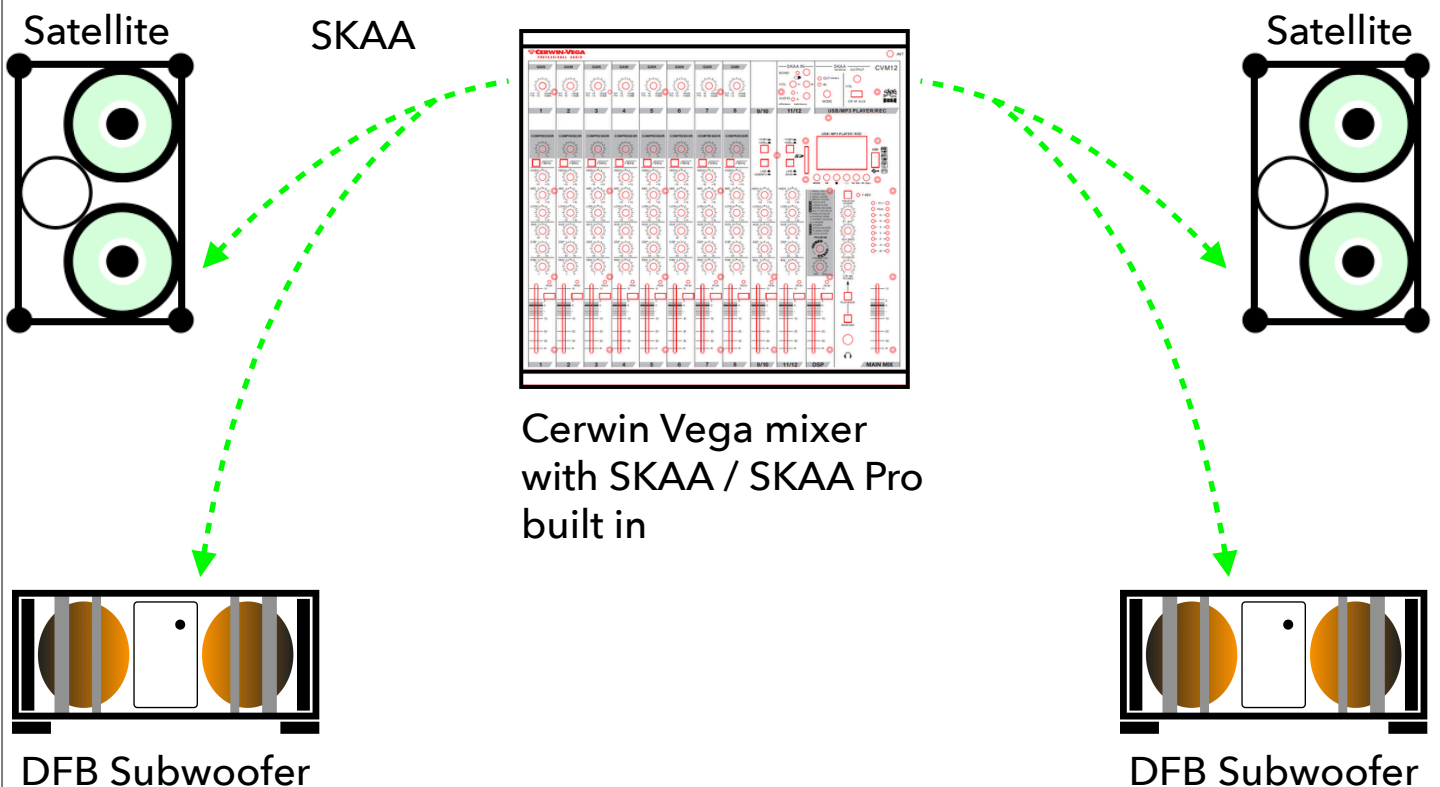

41

... here's the ultra low latency version

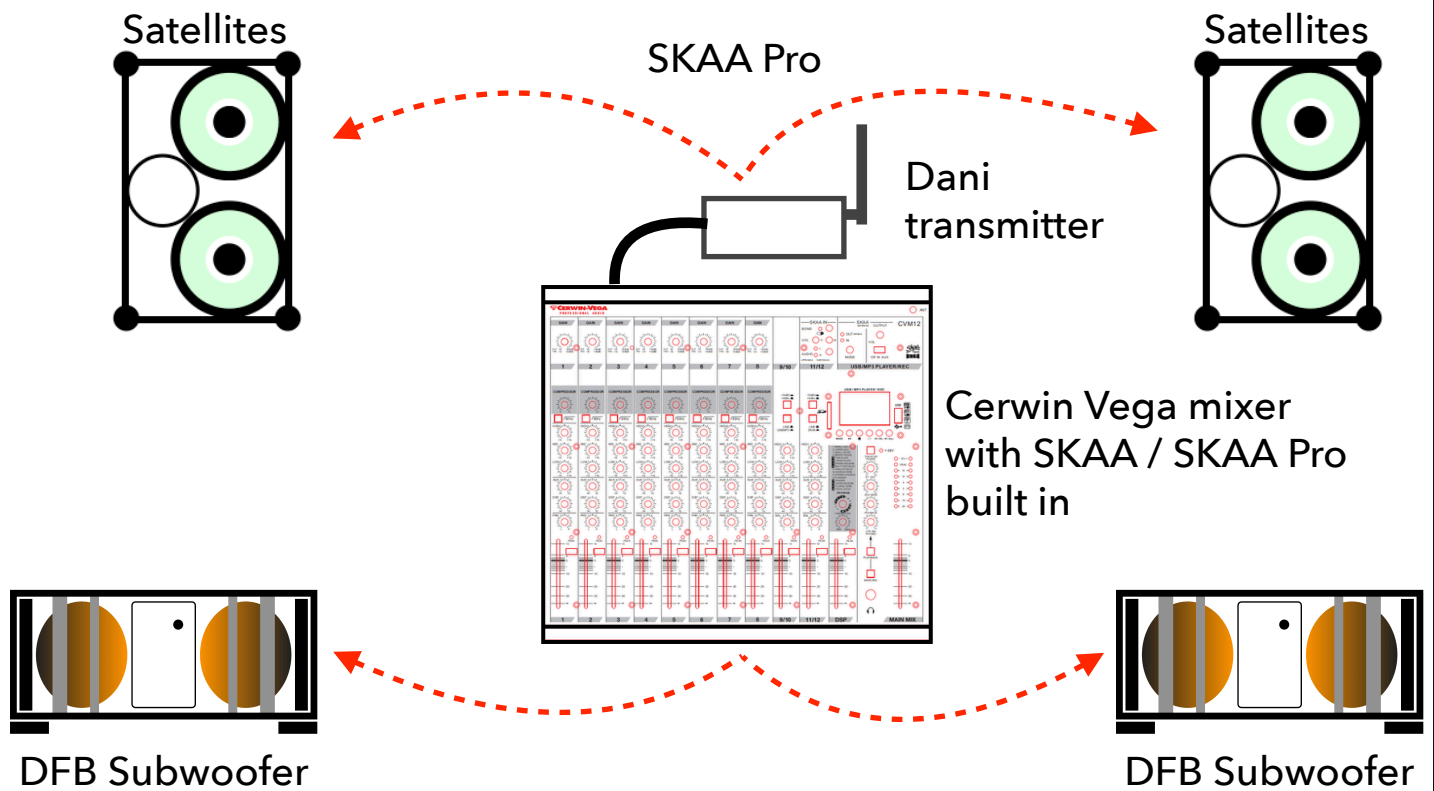

42

convert your old mixer to SKAA wireless

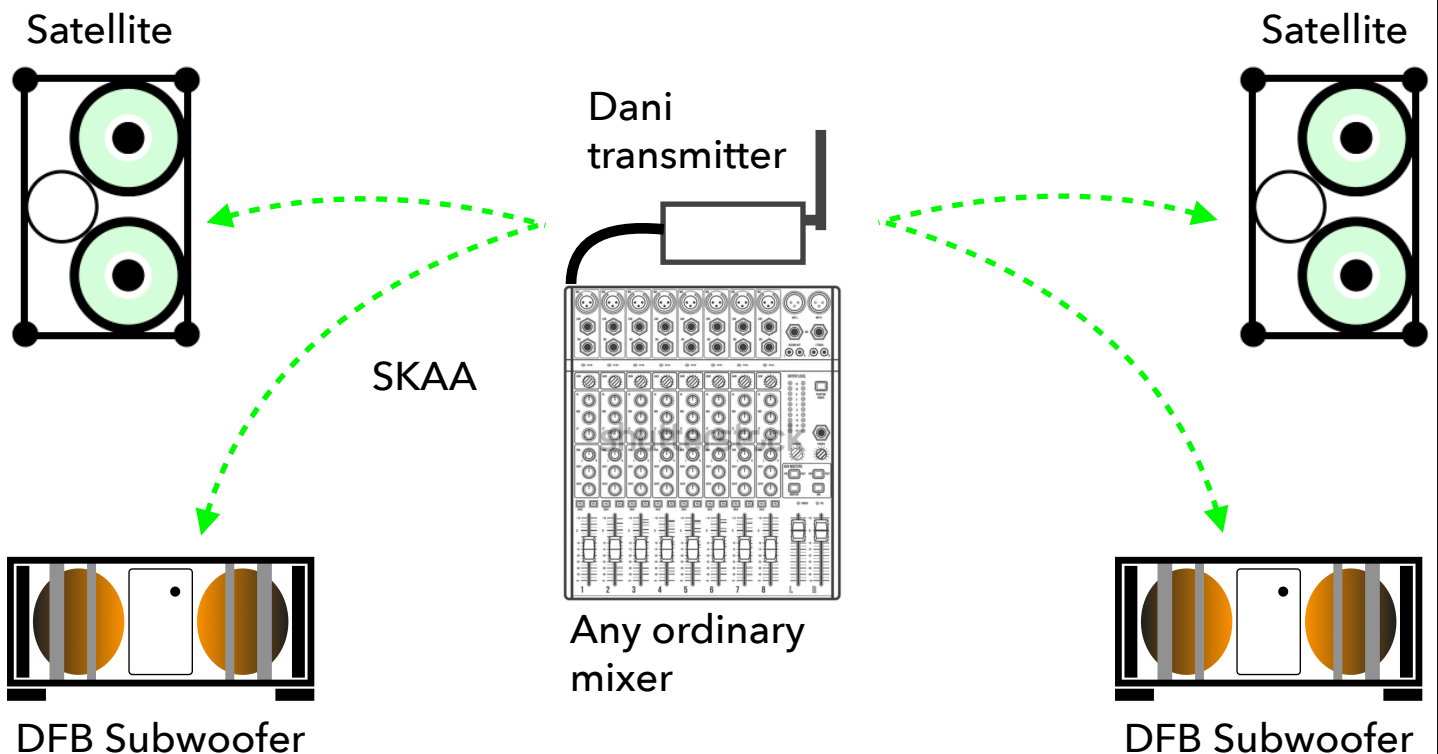

43

... sync wired & wireless

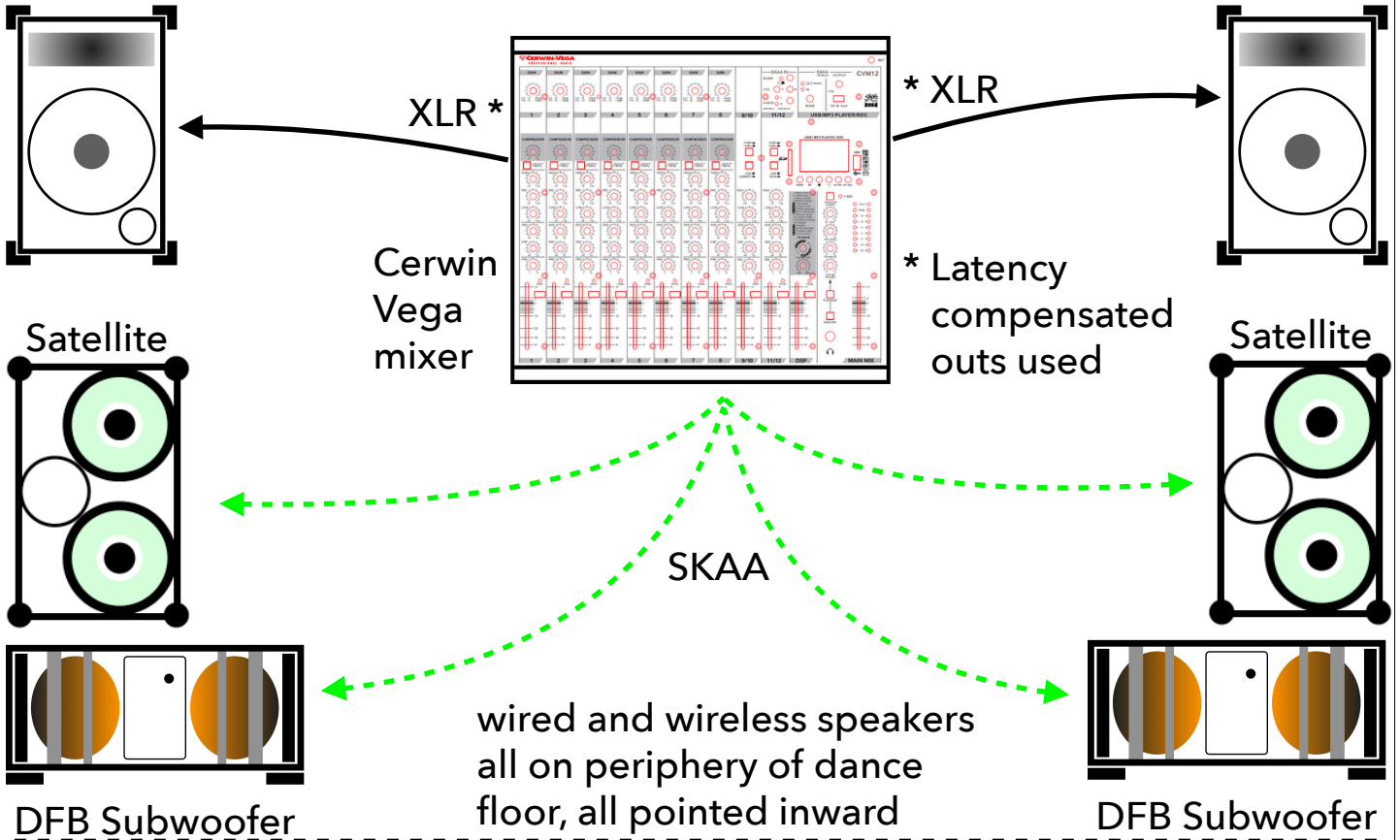

44

... sync'd delay towers

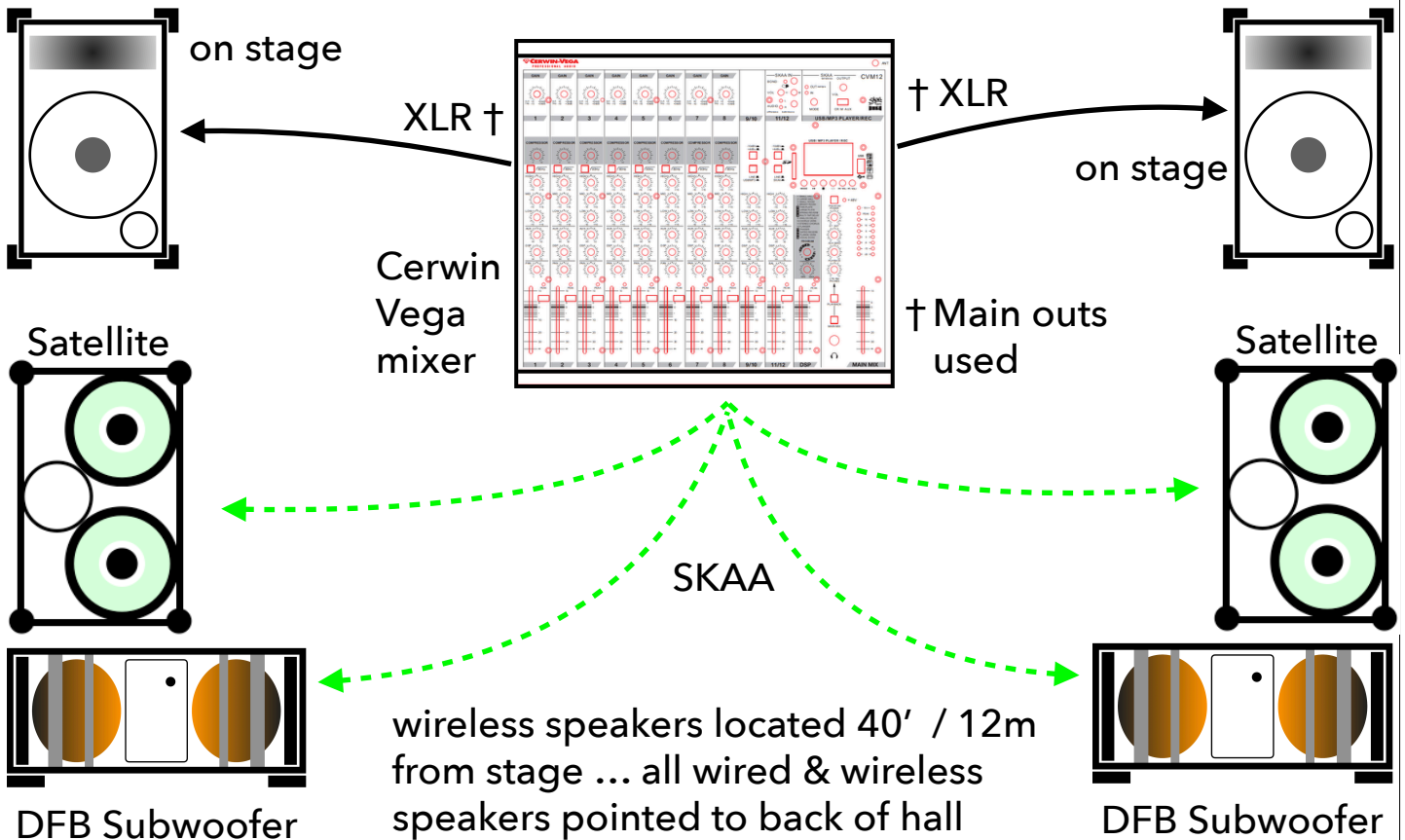

45

... sync any mixer

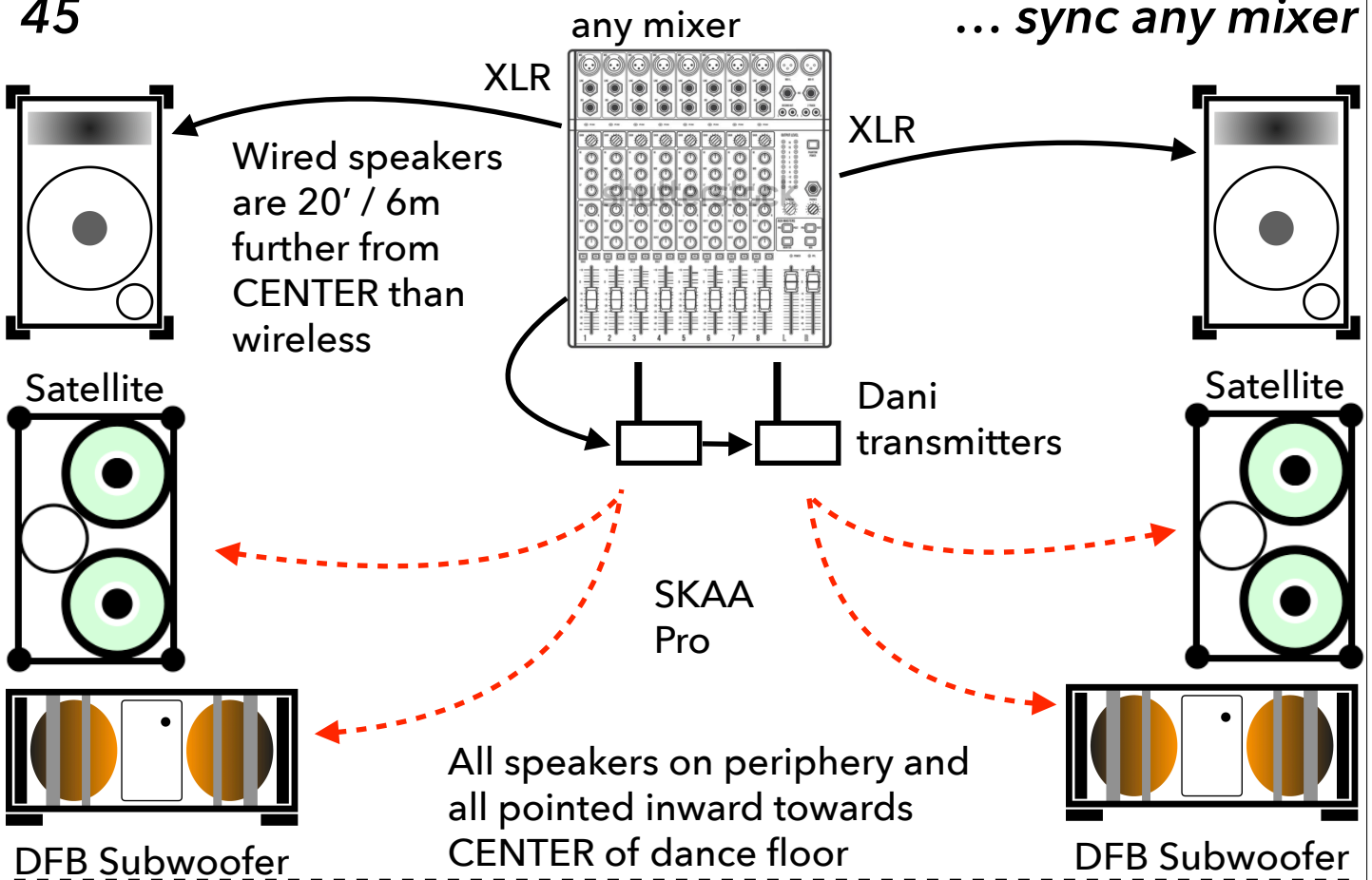

46

... delay towers with any mixer

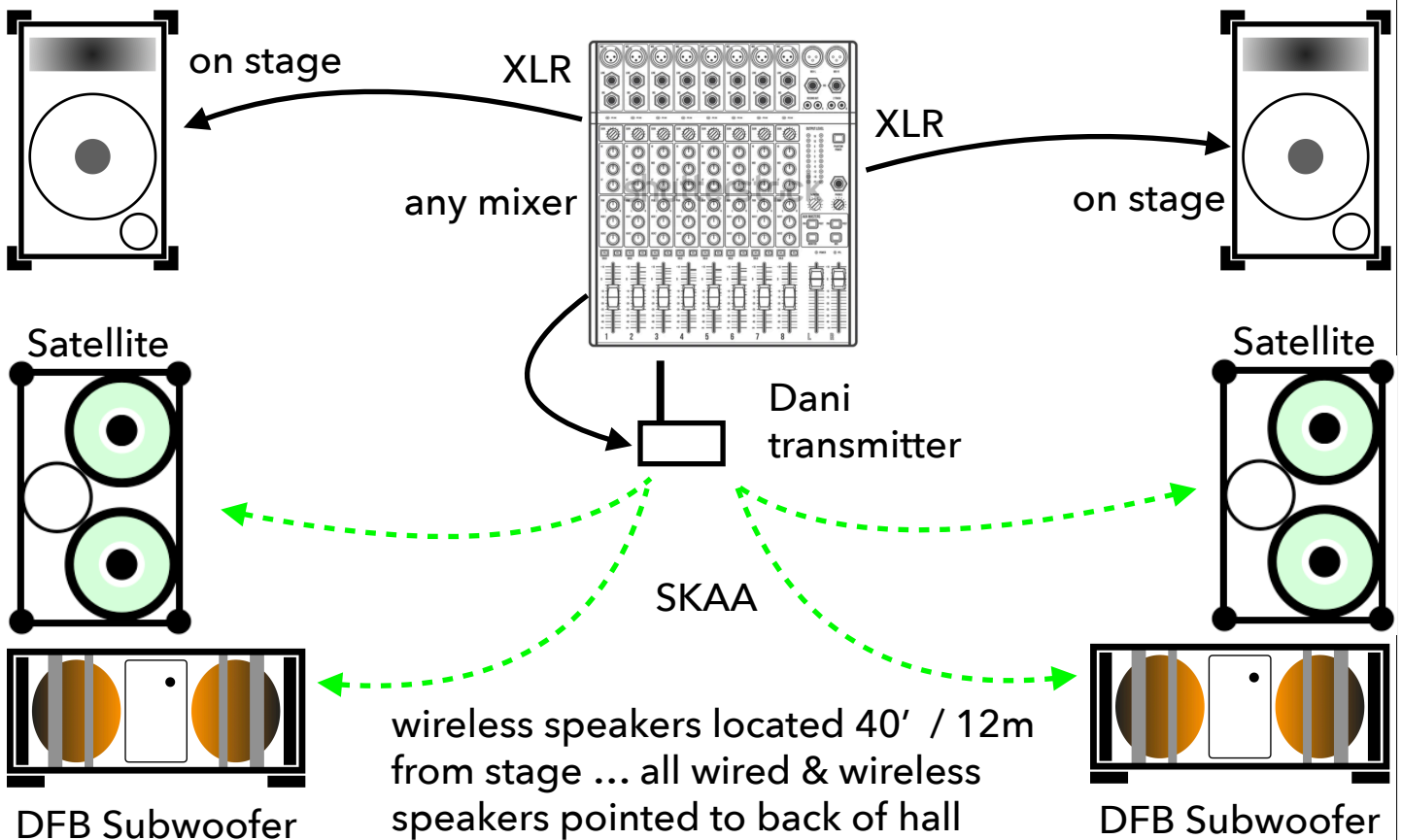

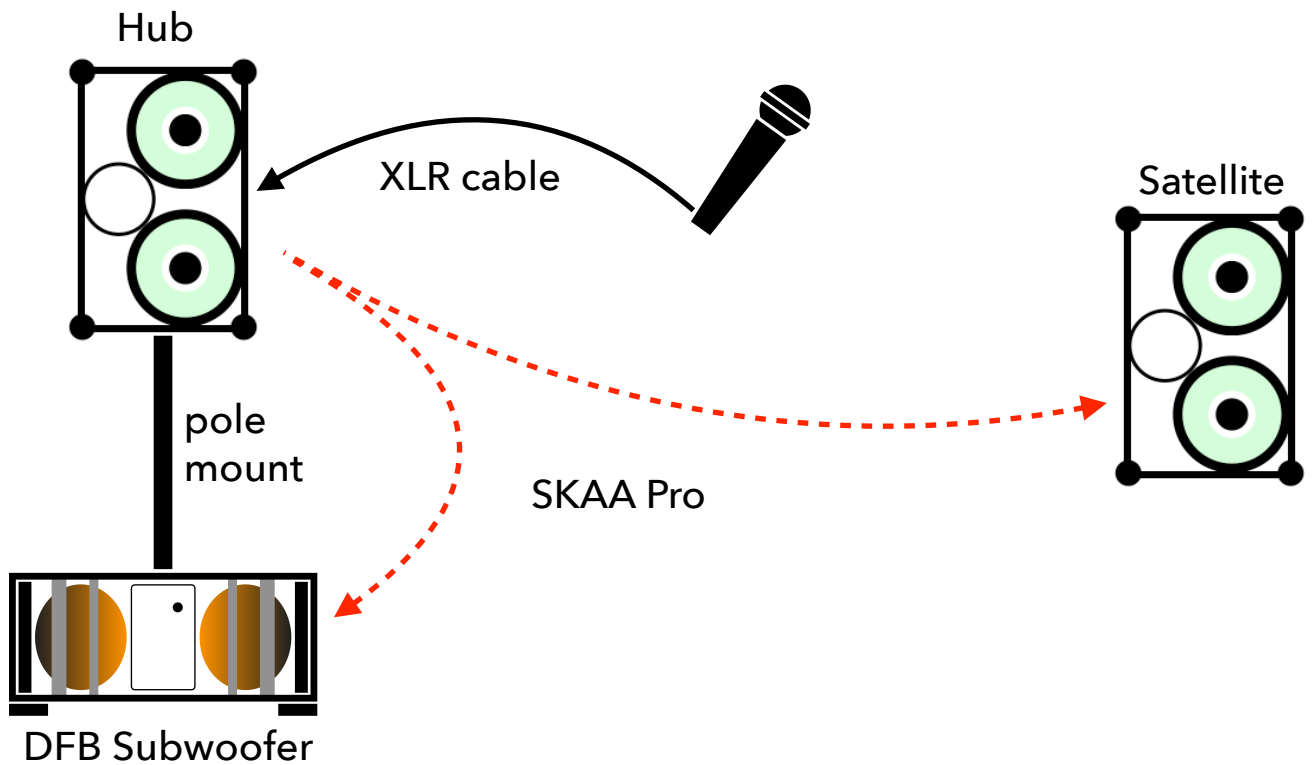
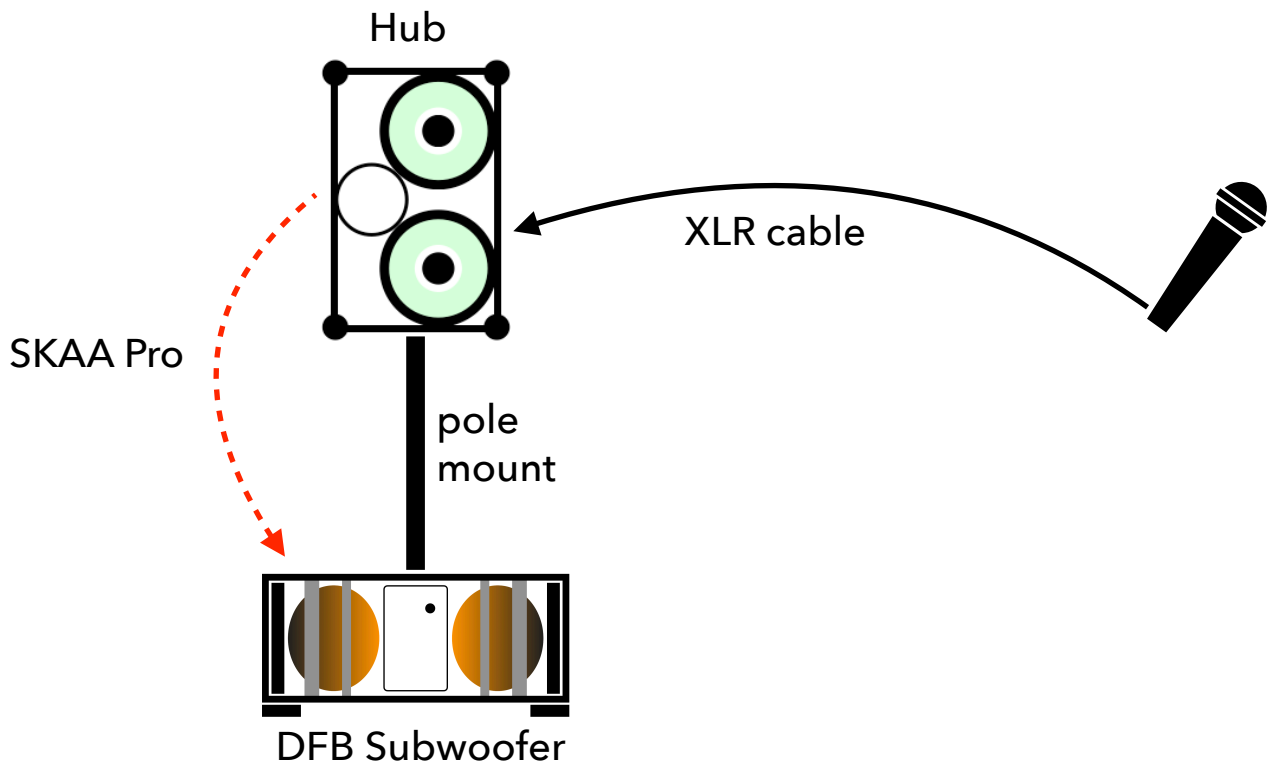

49

sing with background music

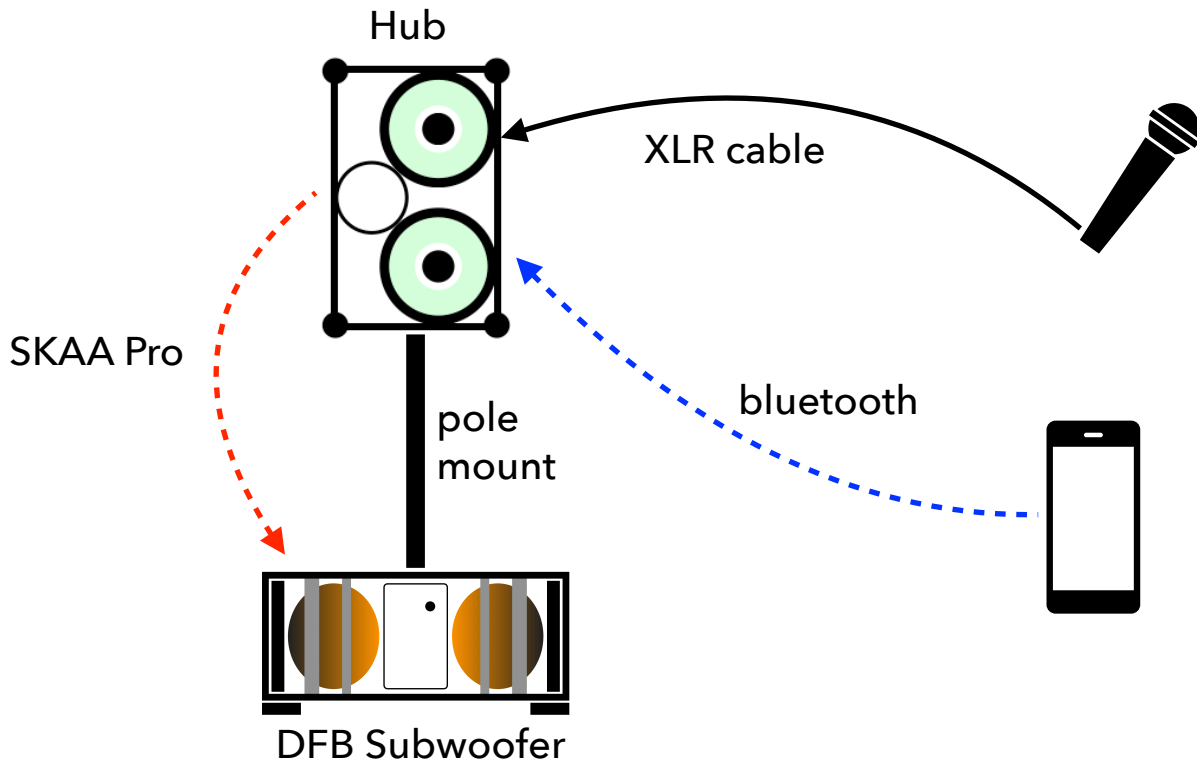

50

... more coverage

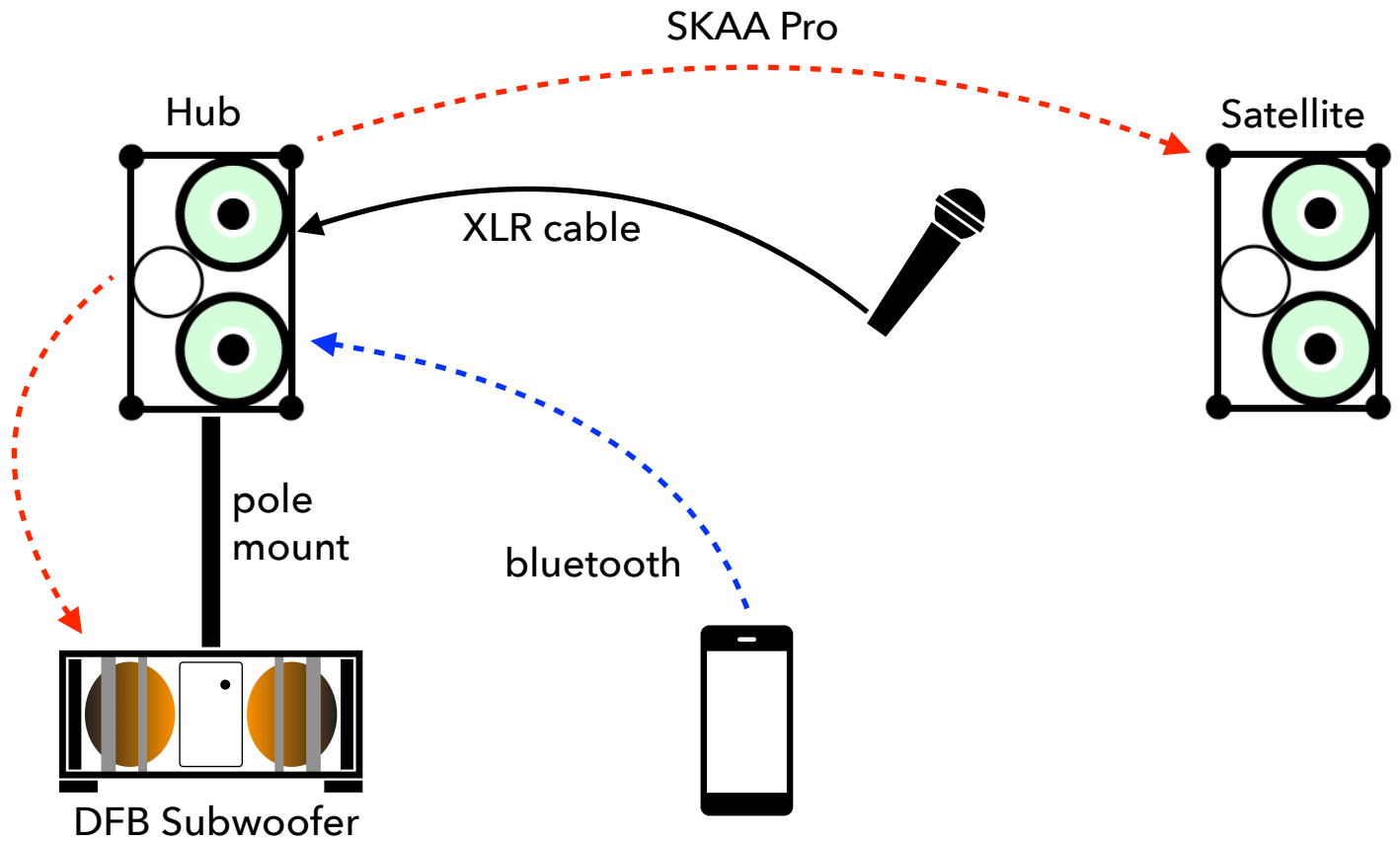

51

... go completely wireless

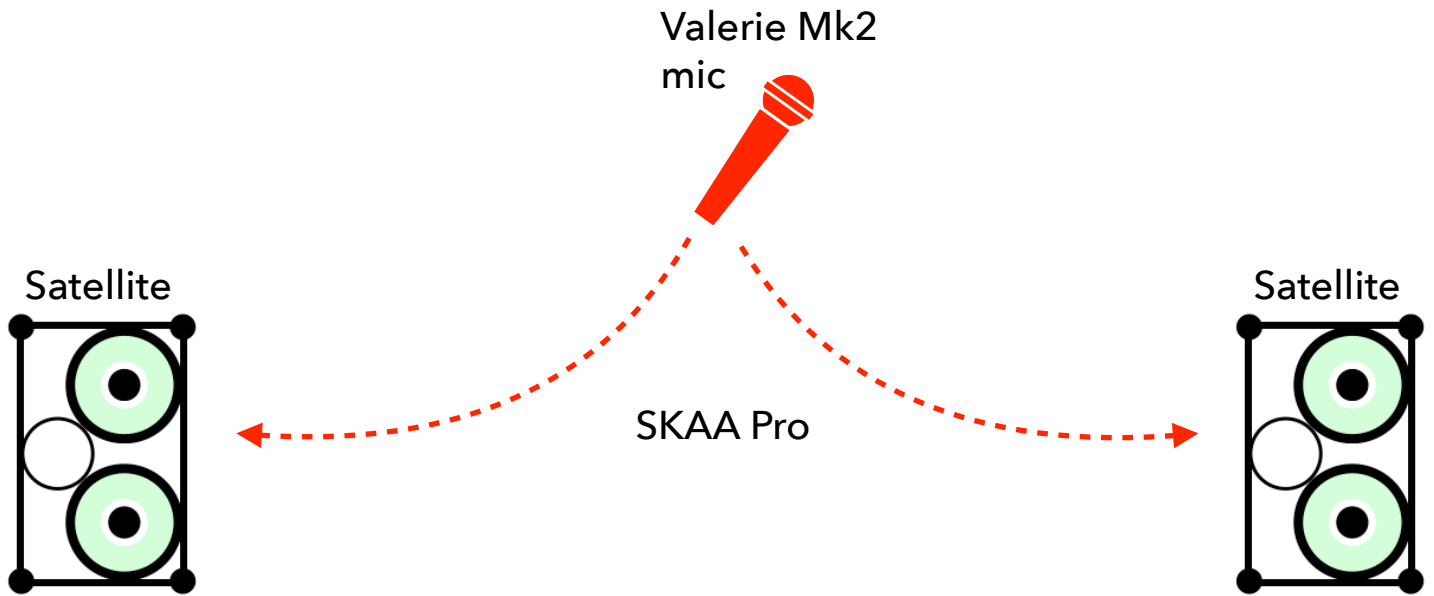

52

... with a backing track

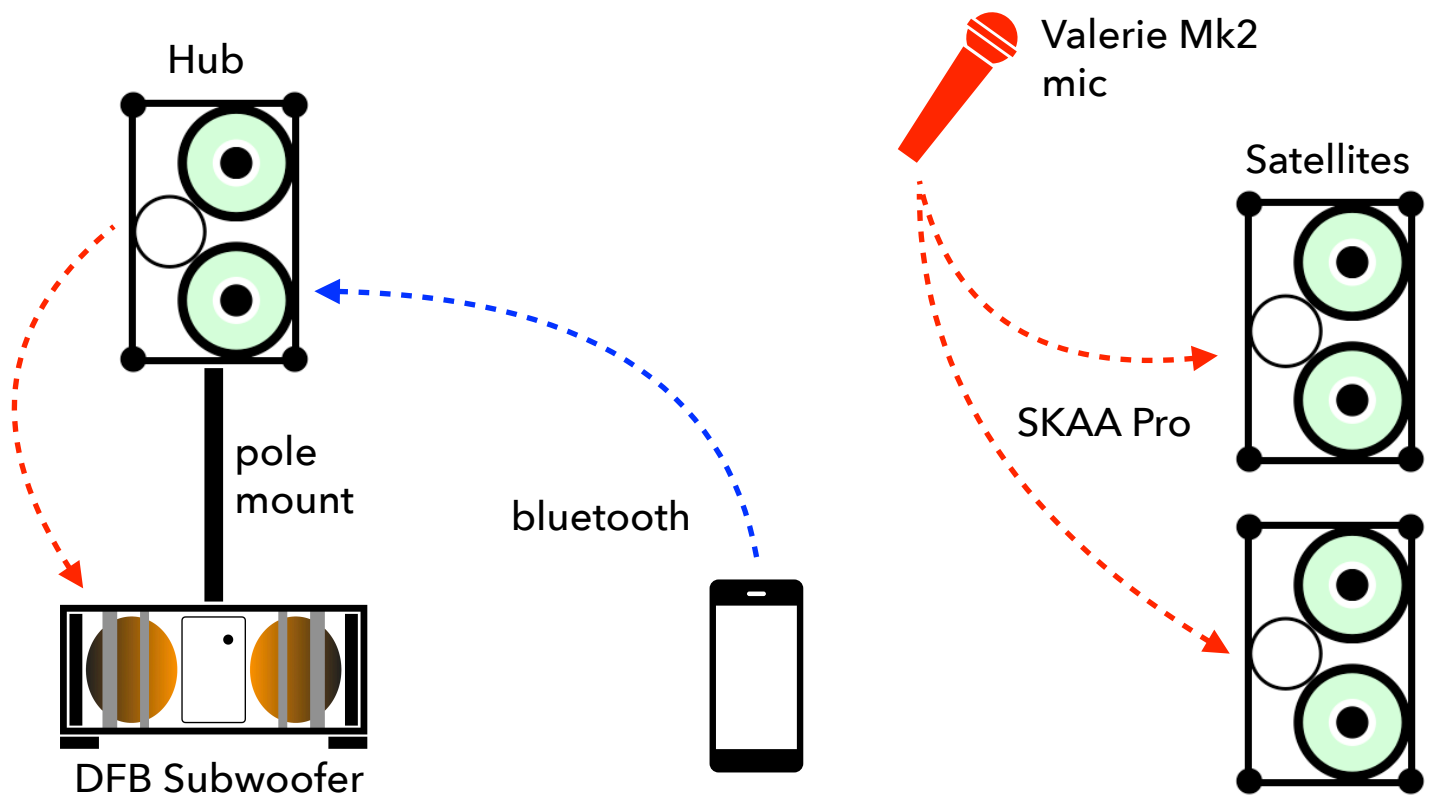

53

... improvise a mic for Karaoke

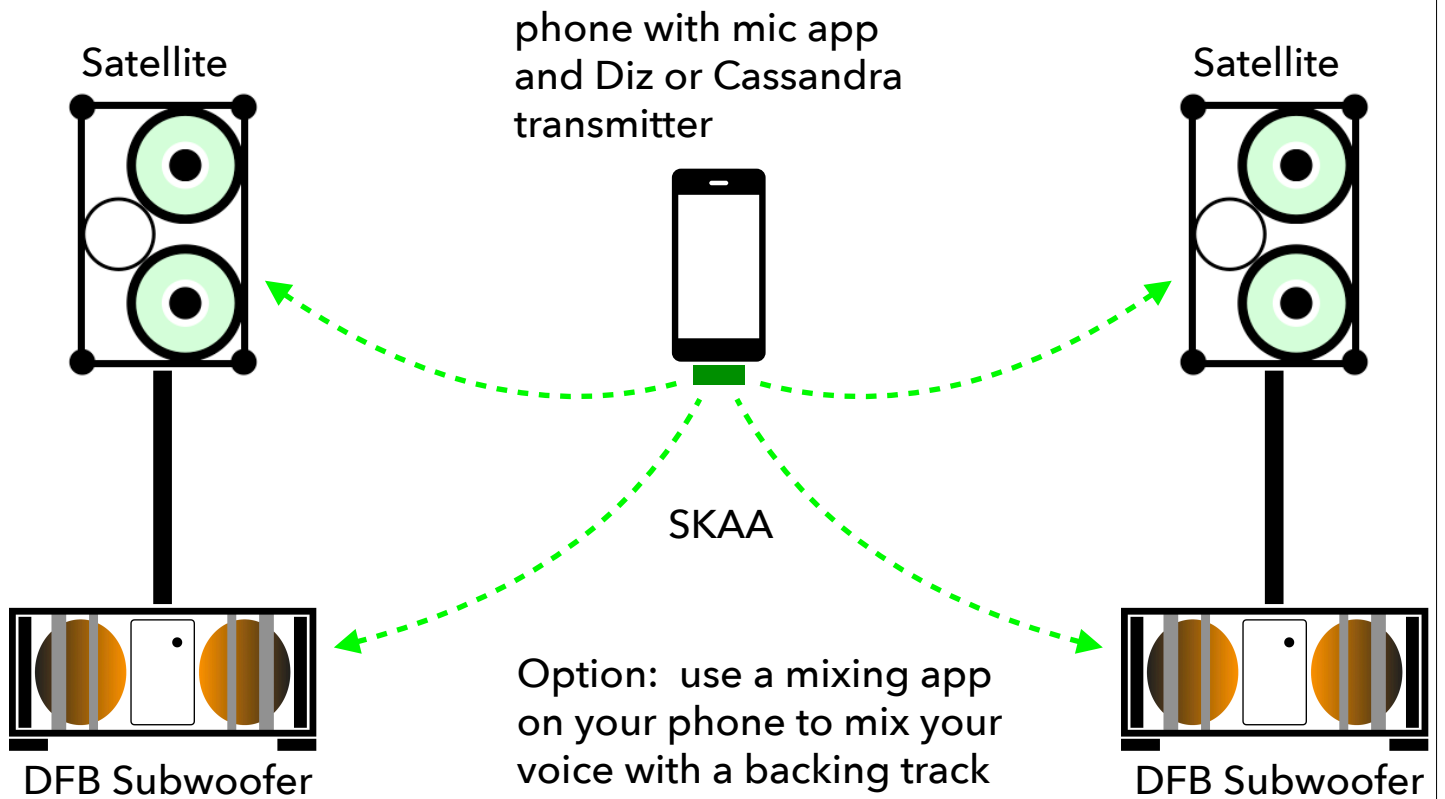

54

2 people can talk or sing sans real mics

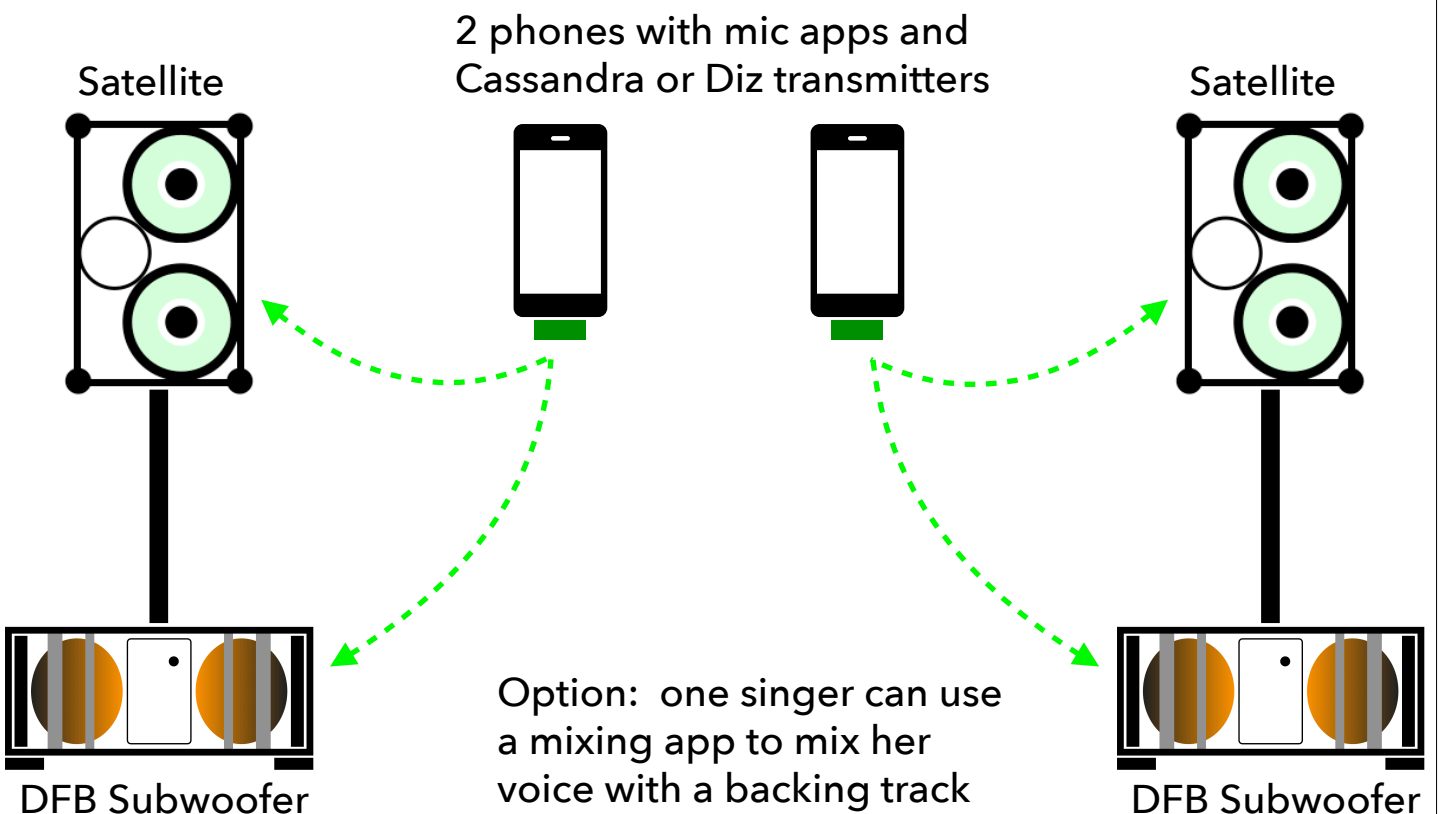

55

2-person jam

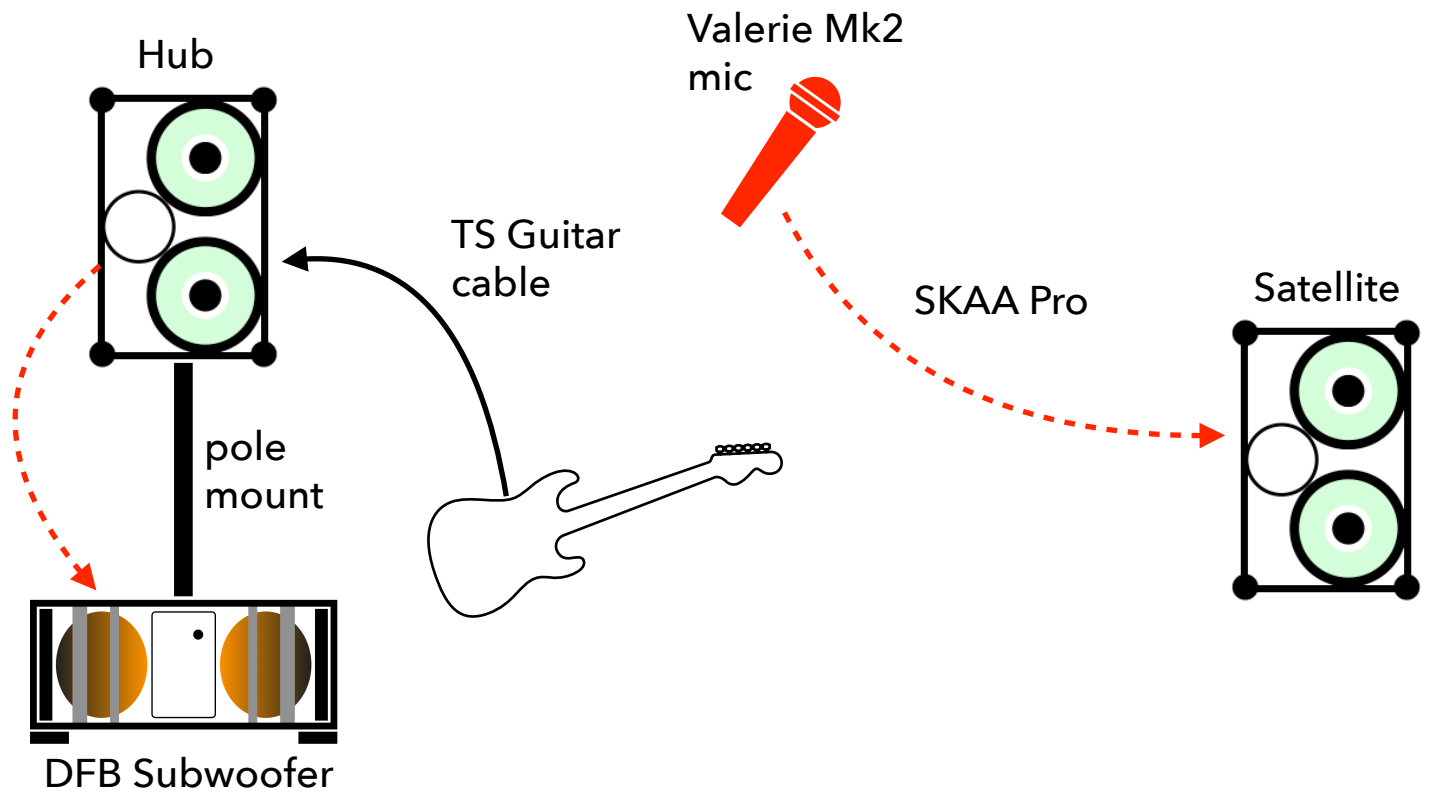

56

2 people + phone app drum machine

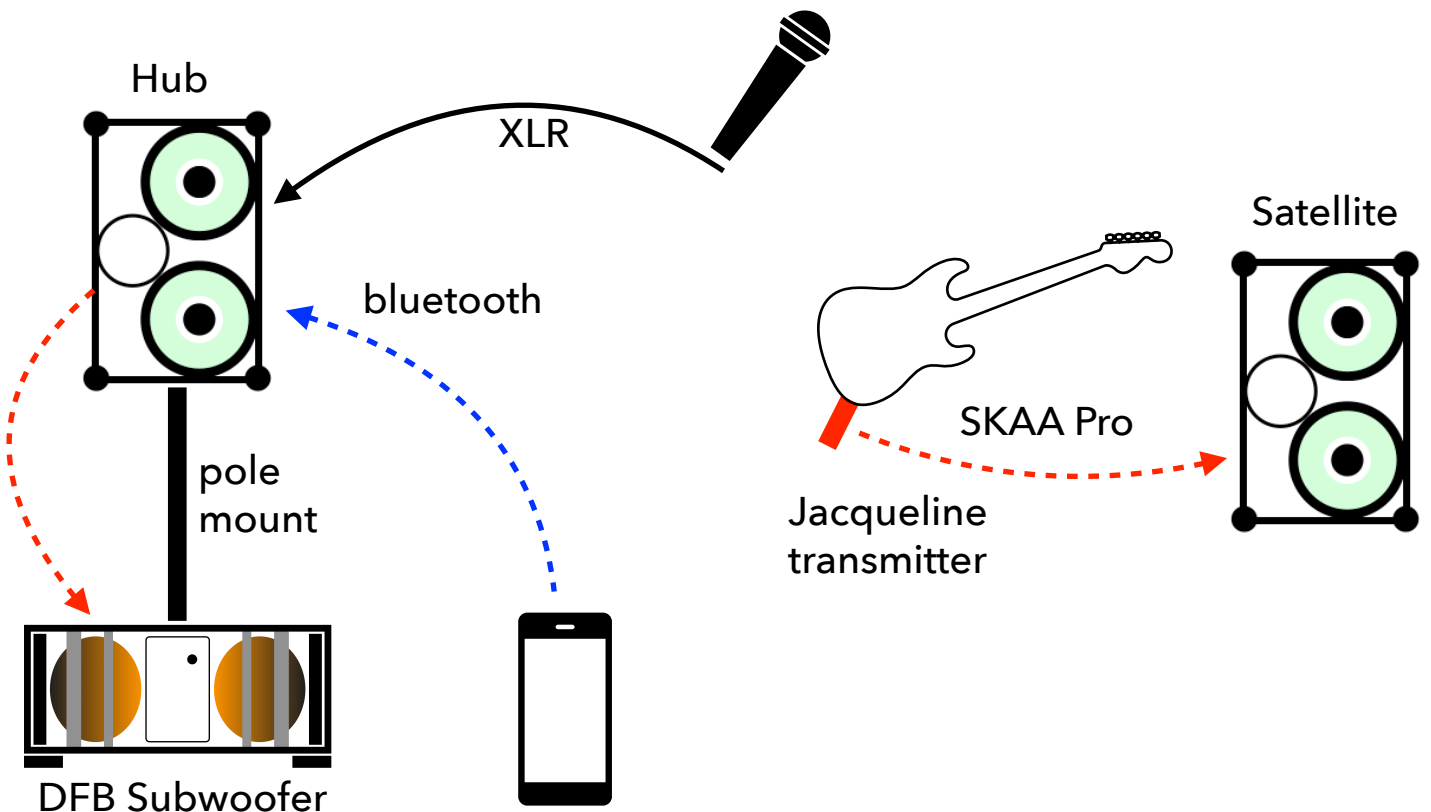

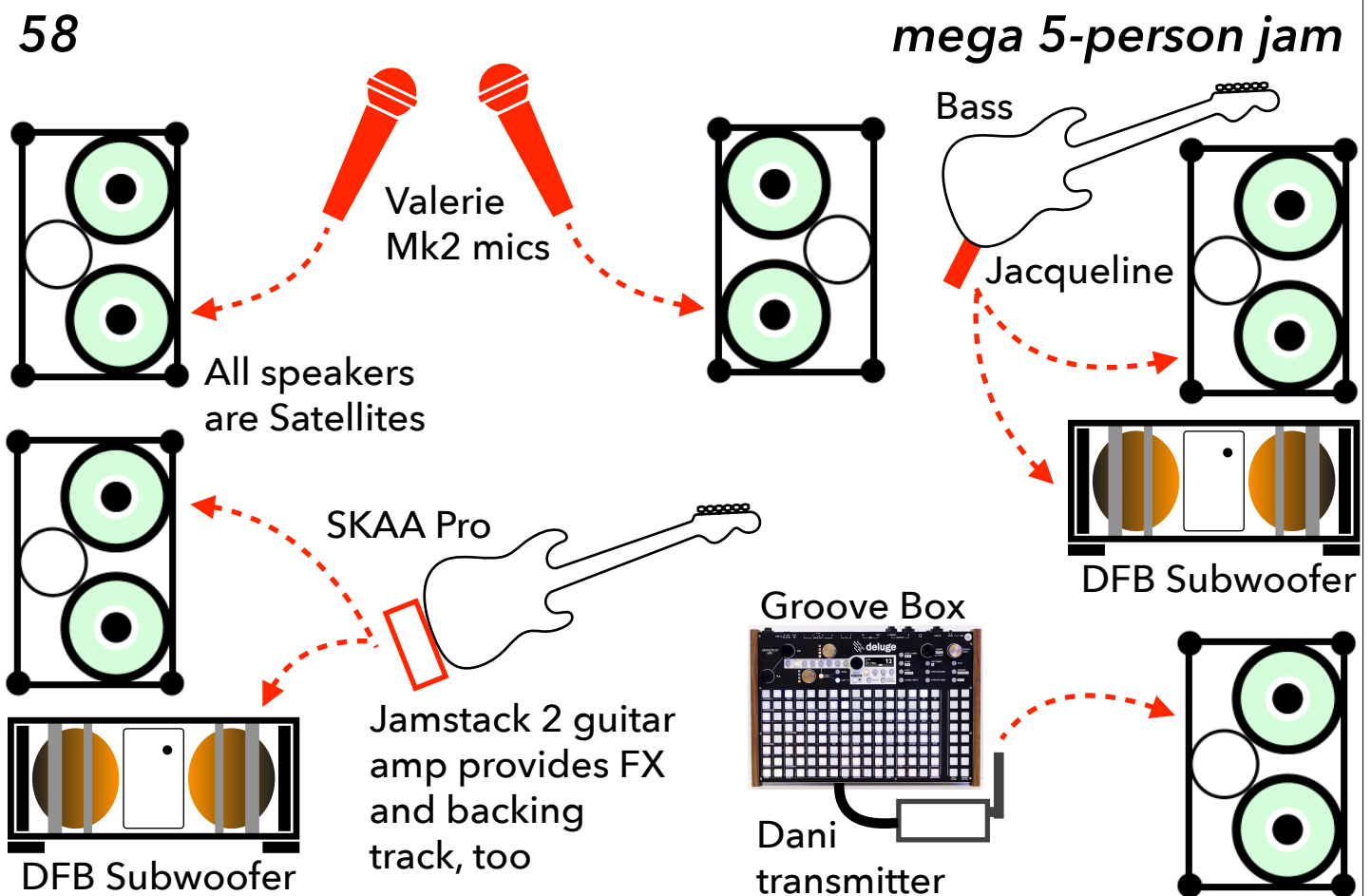
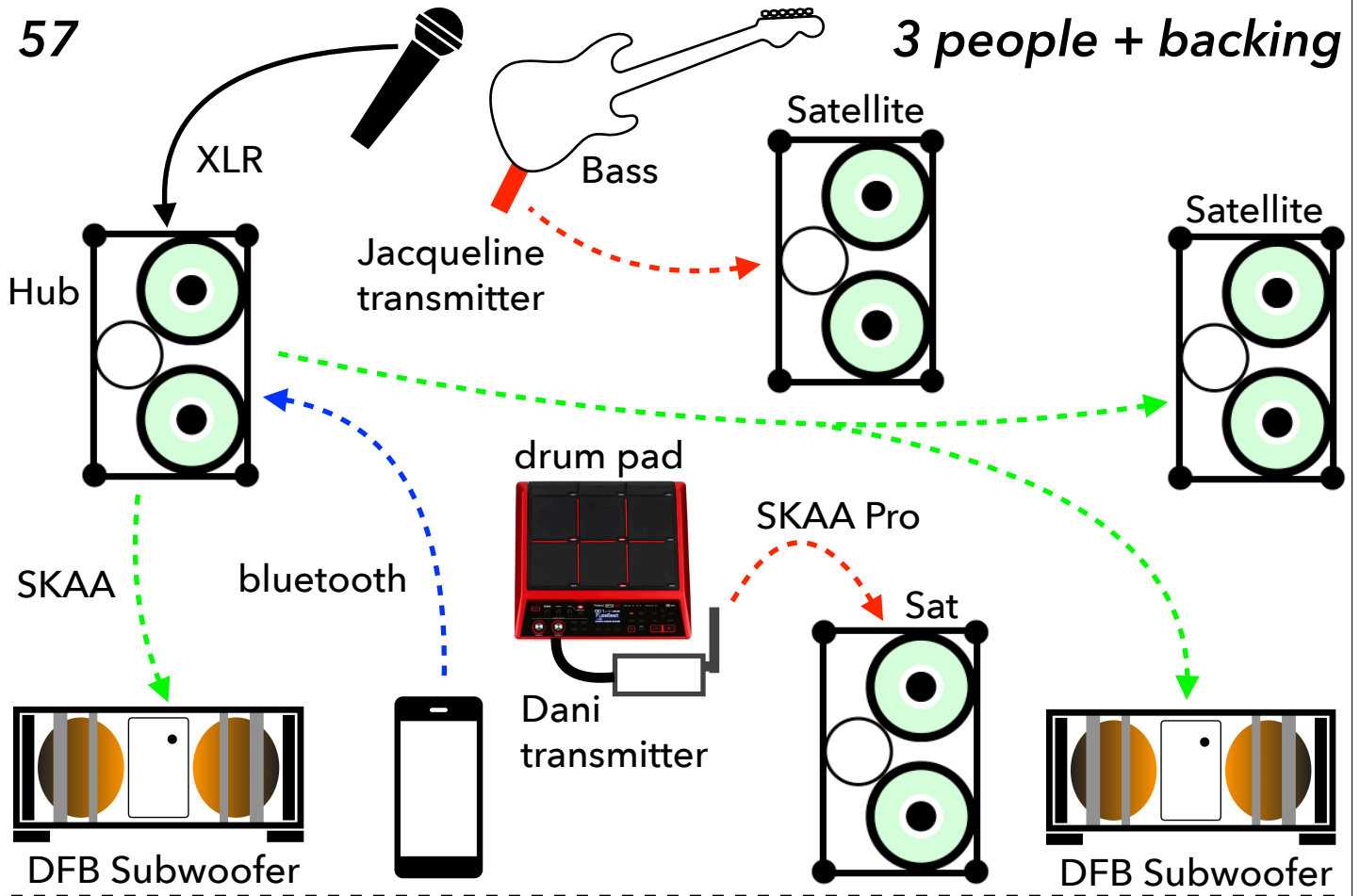

59

phone pool party

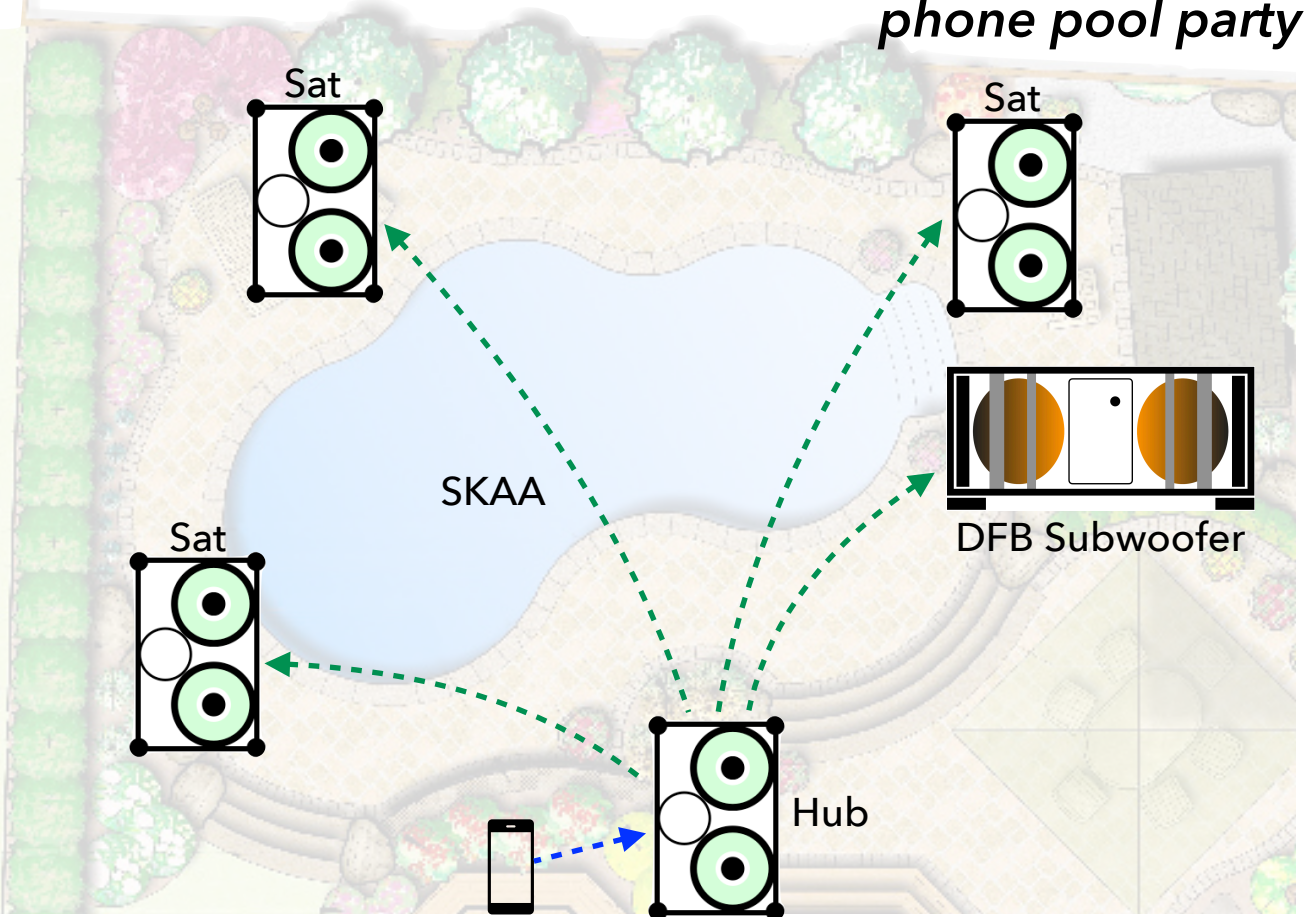

60

... now stream Spotify from the house wifi

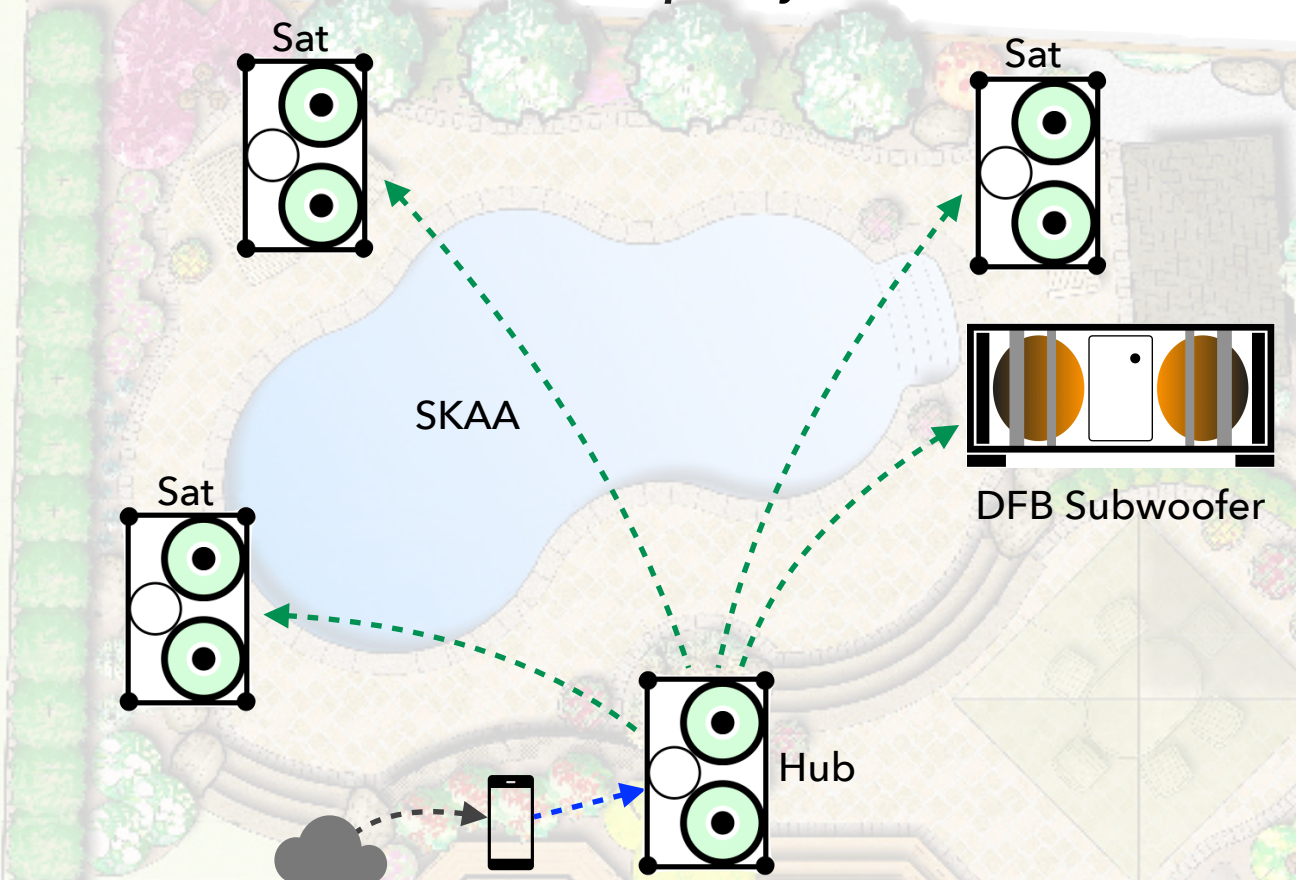

61

DJ pool party

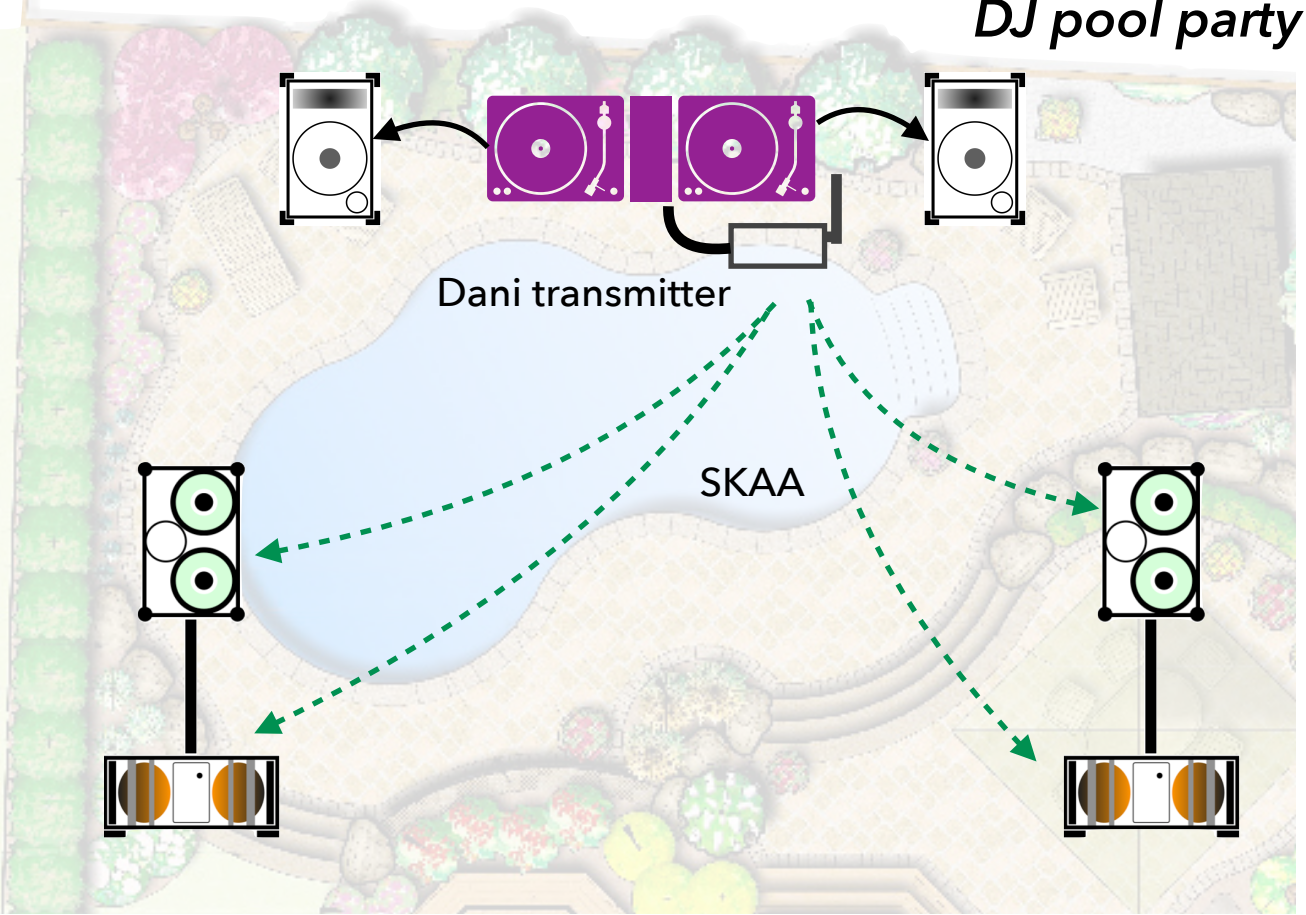

62

mondo DJ pool party

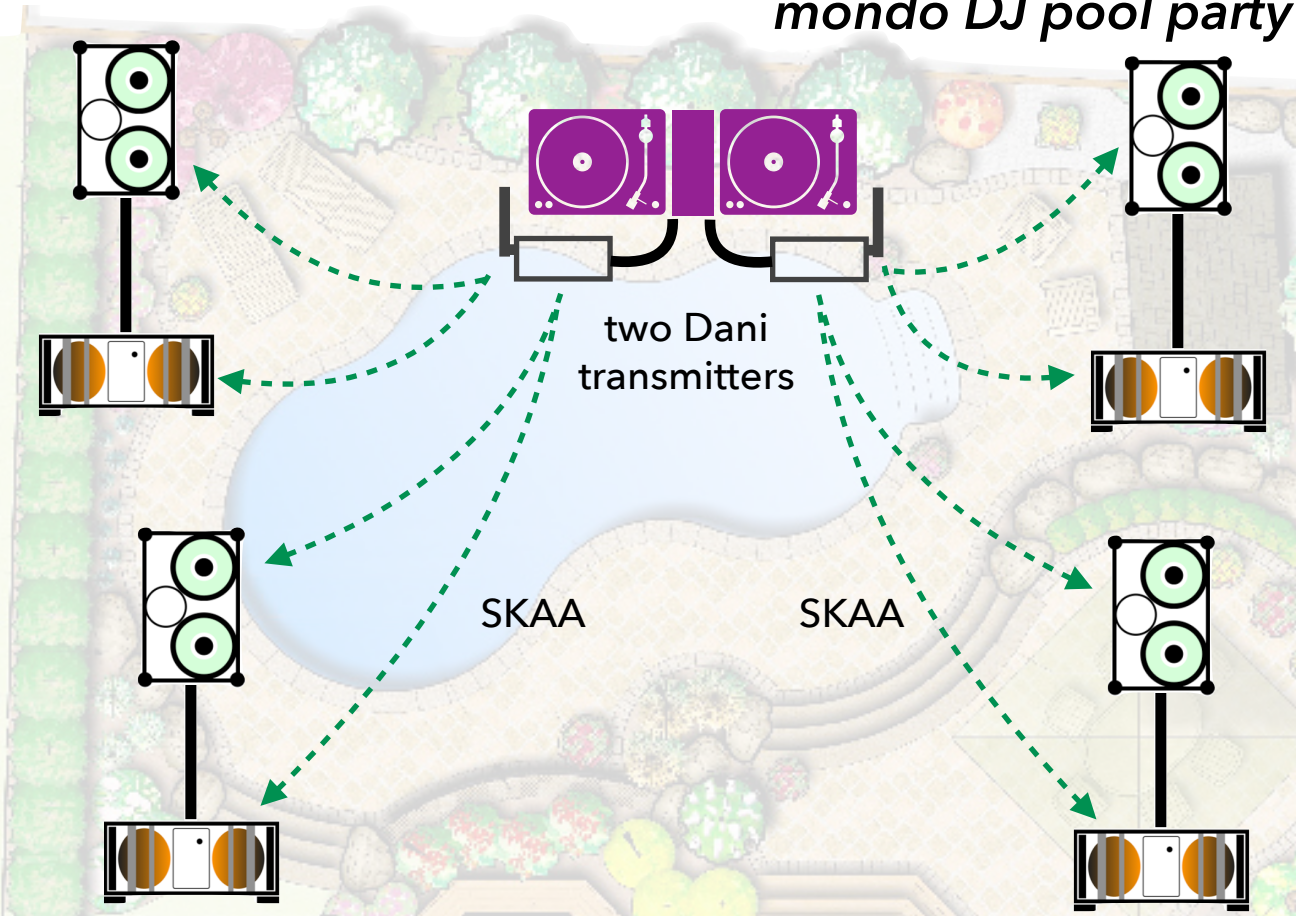

63

DJ system

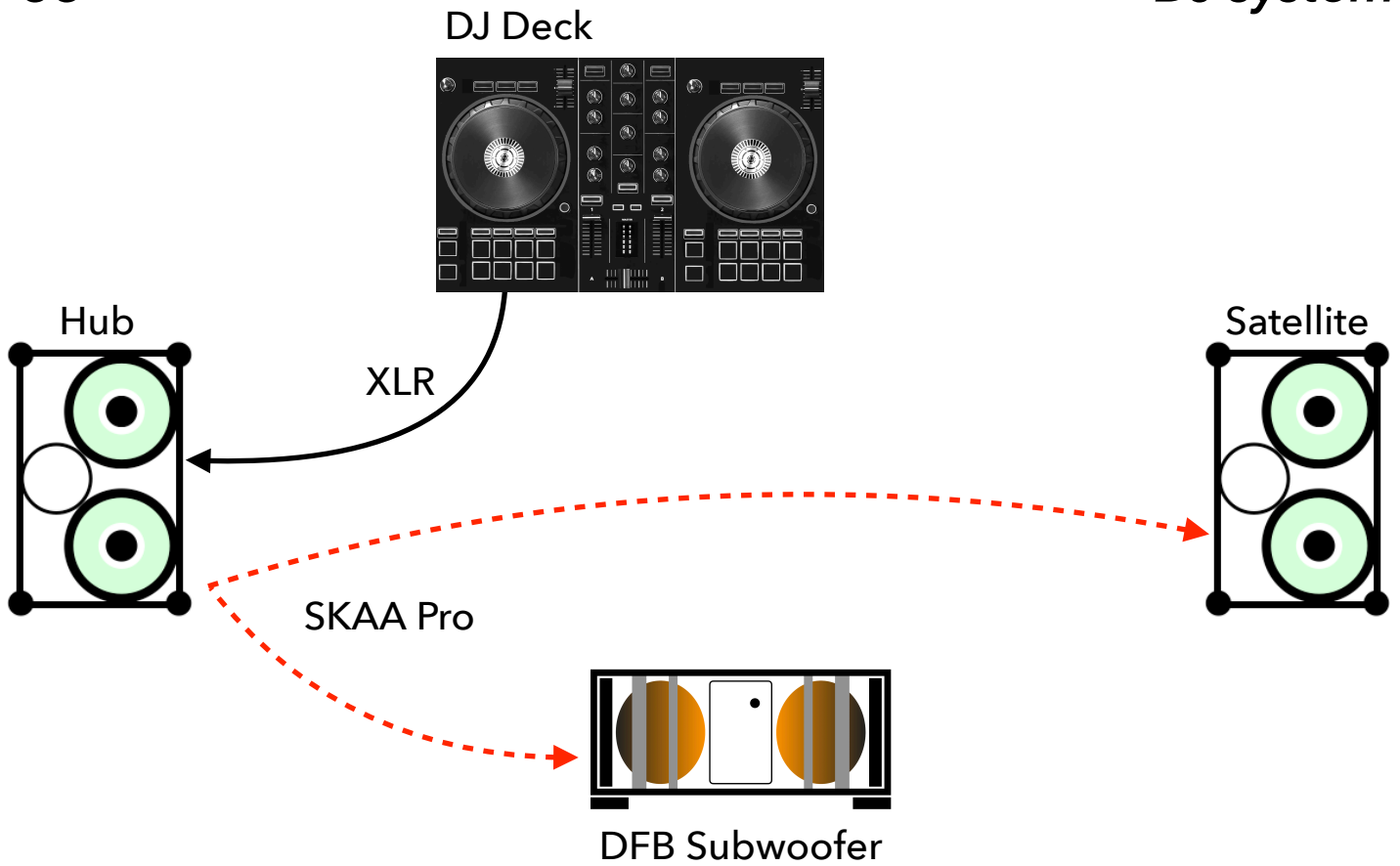

64

... with SKAA headphones

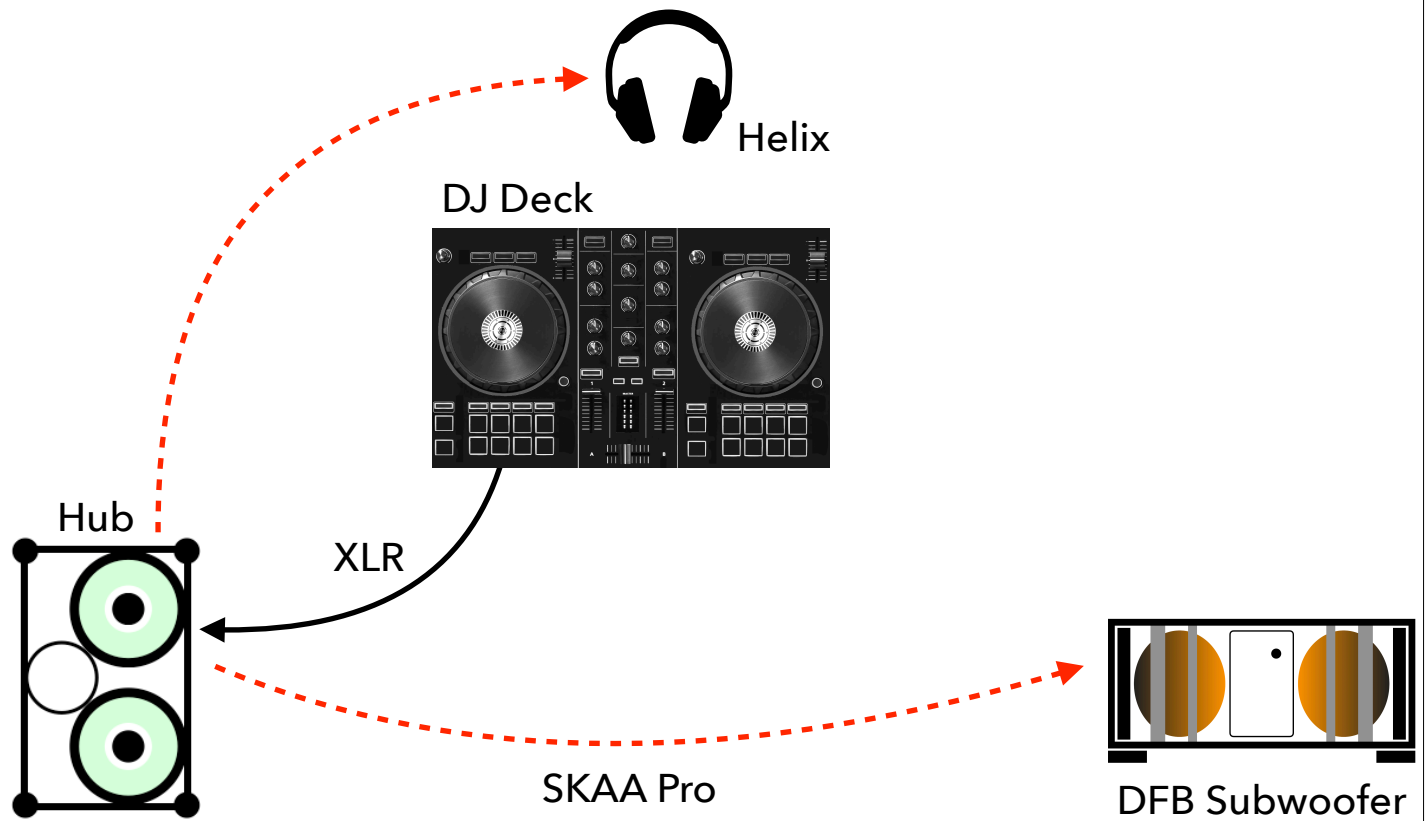

65

dope DJ system

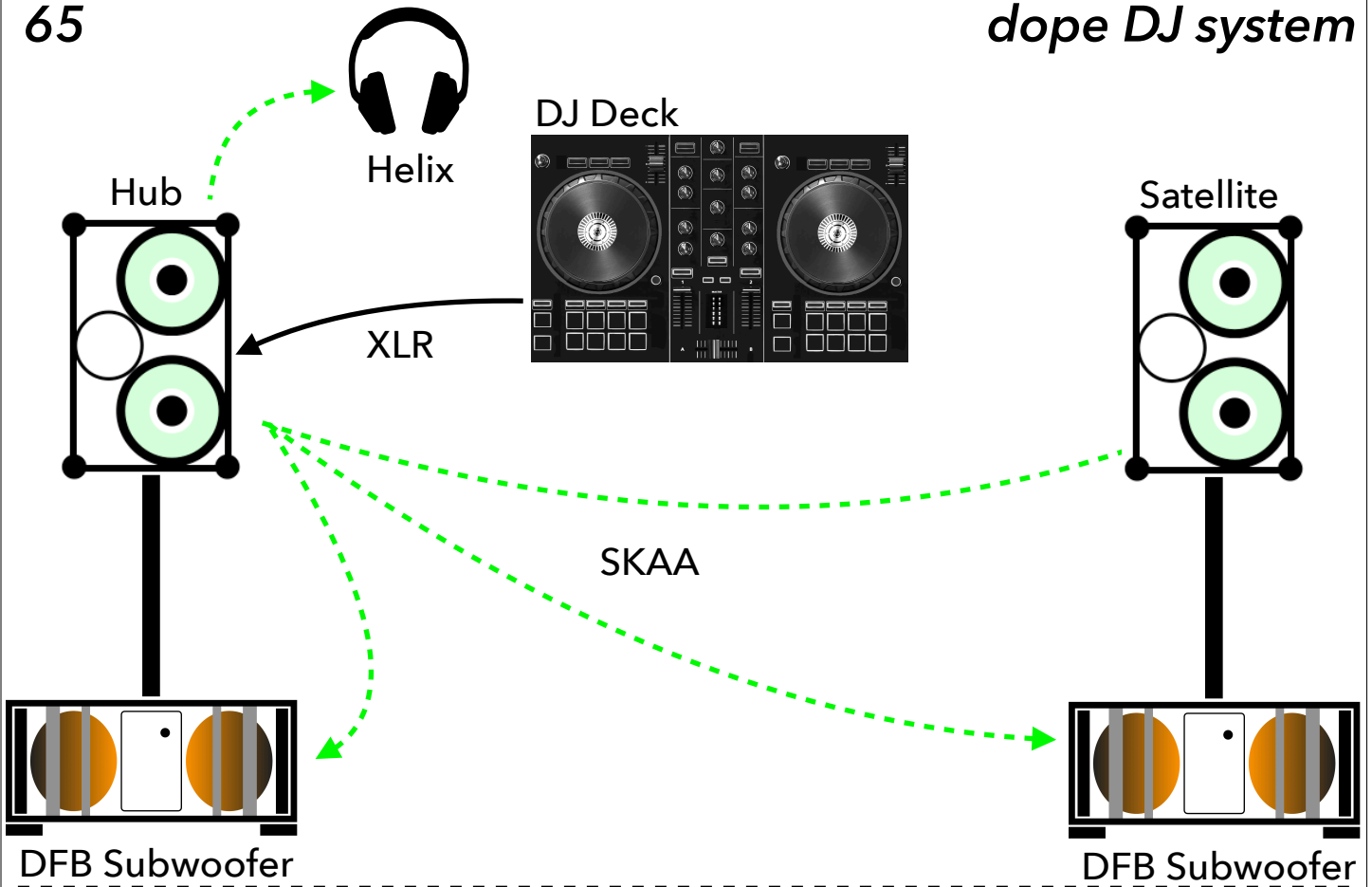

66

... pro pro fully-wireless DJ

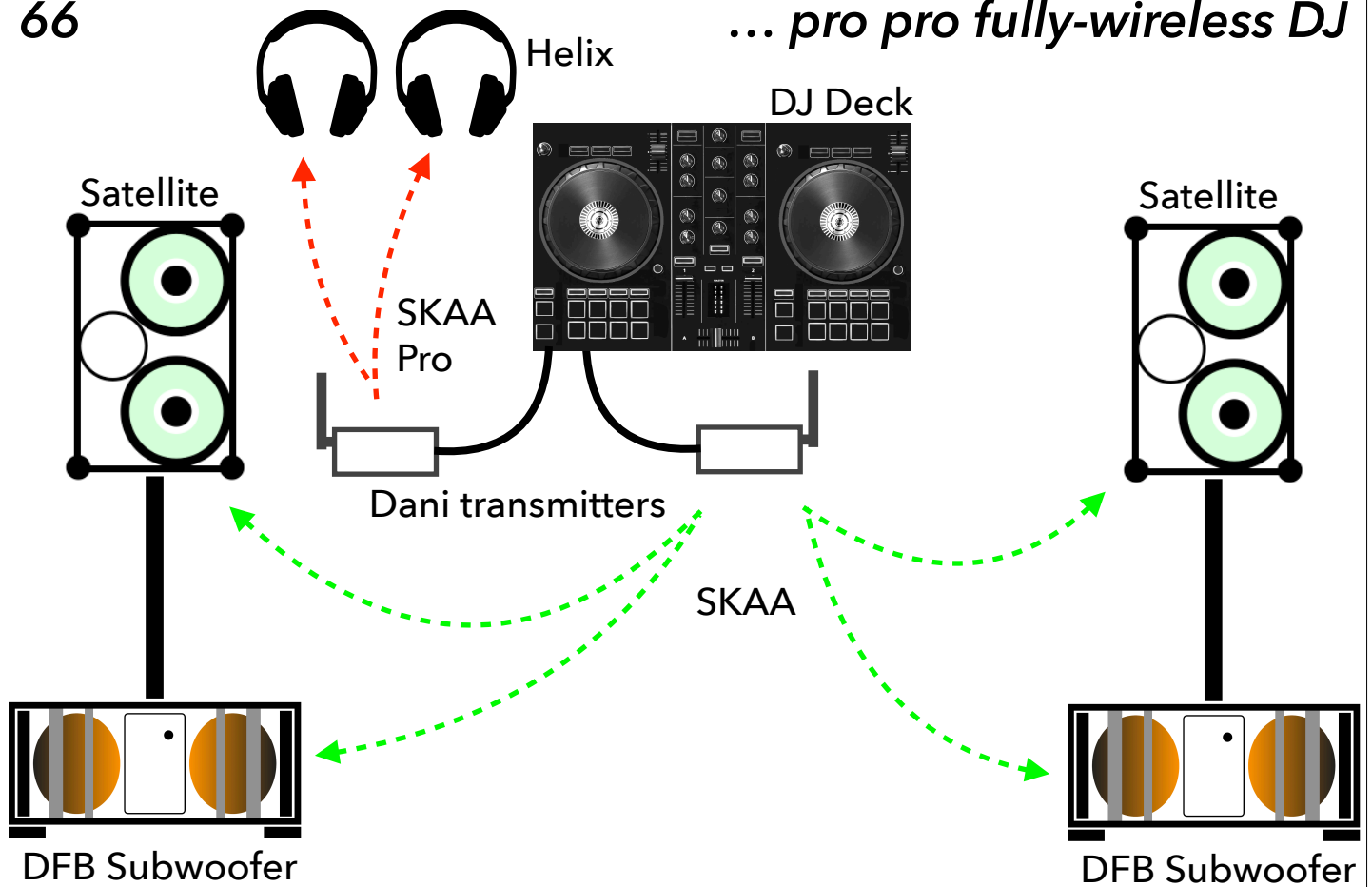

67

ultra low latency towers I

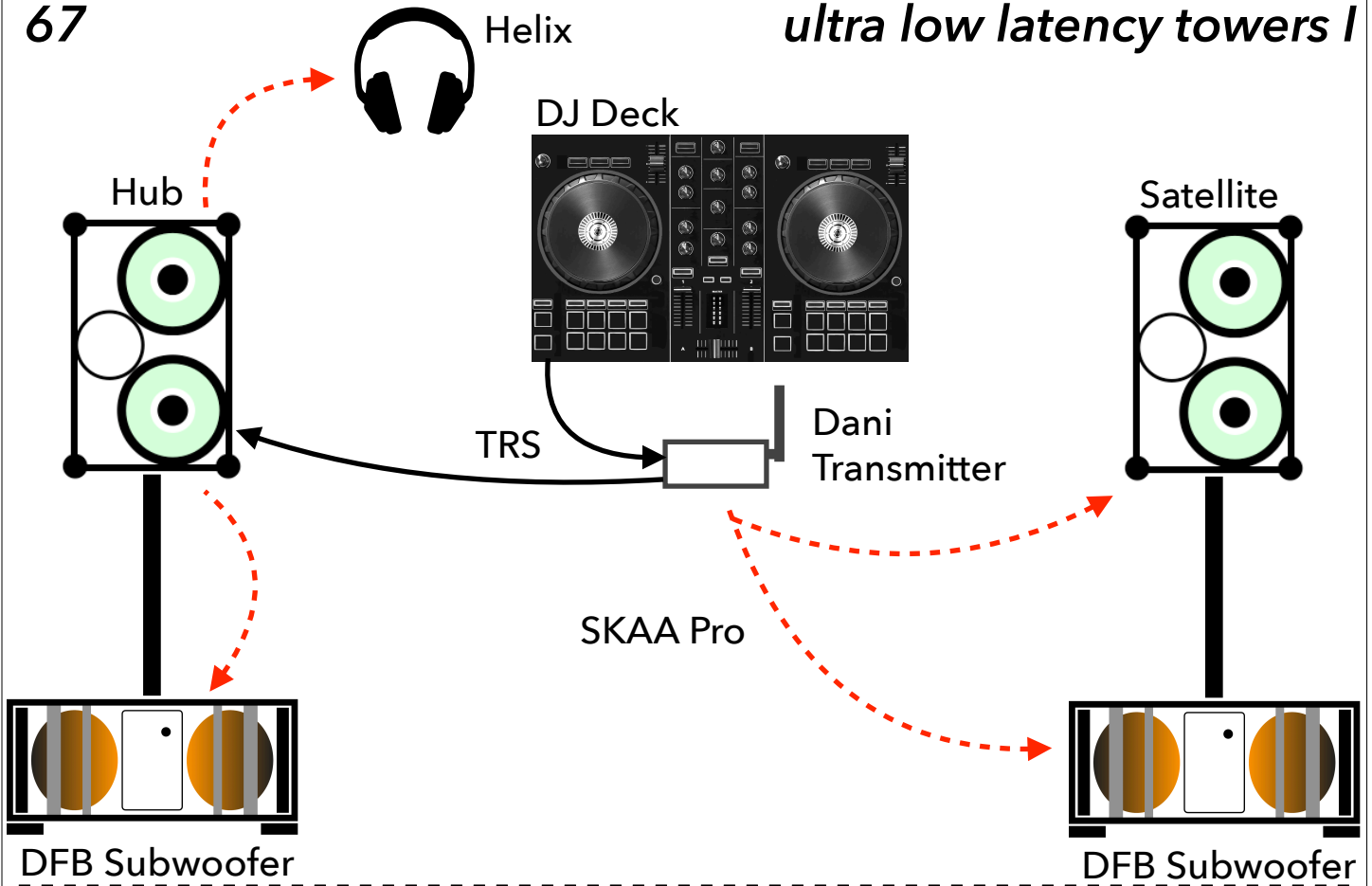

68

ultra low latency towers II

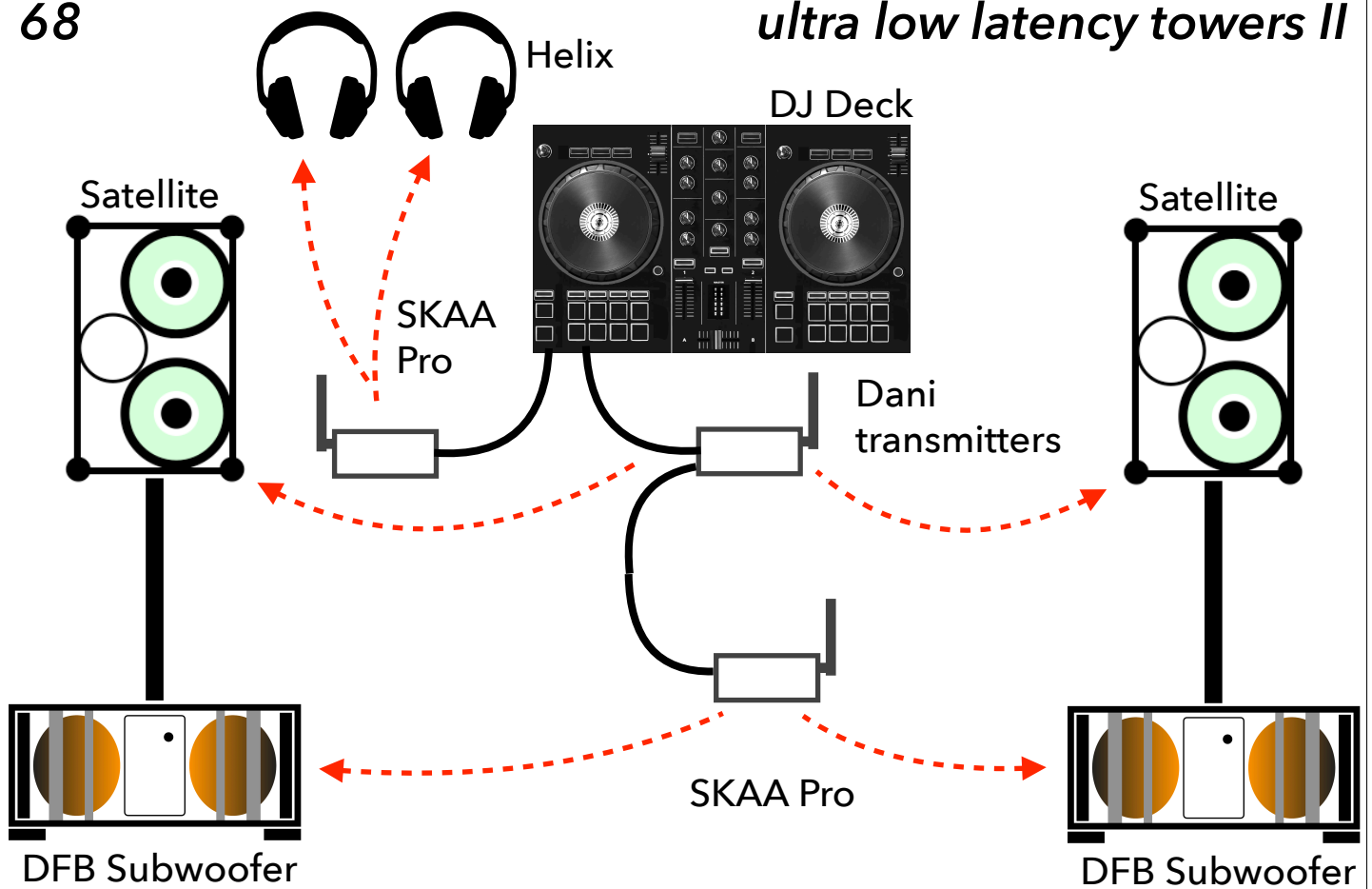



⚠️ Danger: Risk of Death from Shock
3.6V Ni-MH Rechargeable
Model: PL5508
SERIAL NO: 5508-0008
Battery Cycle 150-400 Cycles
Input: 100VAC 4.0A
Skua
pro
Designed in Canada
Assembled in China
FCC ID: OPMPL5508
IC: 3534A-PL5508
UK CB CE RoHS
Skua.com
DJI@skualabs.com